

Chapter Thirty-four
CROSS SECTION ELEMENTS

BUREAU OF DESIGN AND ENVIRONMENT MANUAL

Chapter Thirty-four
CROSS SECTION ELEMENTS

Table of Contents

<u>Section</u>	<u>Page</u>
34-1 GENERAL	34-1.1
34-1.01 Definitions	34-1.1
34-1.02 Nomenclature	34-1.3
34-1.03 Classification by Area Type	34-1.3
34-2 ROADWAY SECTION	34-2.1
34-2.01 Travel Lanes	34-2.1
34-2.01(a) Width	34-2.1
34-2.01(b) Cross Slopes	34-2.1
34-2.01(c) Stage Construction	34-2.2
34-2.02 Shoulders	34-2.2
34-2.02(a) Functions	34-2.2
34-2.02(b) Widths	34-2.3
34-2.02(c) Additional Shoulder Thickness	34-2.4
34-2.02(d) Cross Slopes	34-2.4
34-2.02(e) Rumble Strips	34-2.5
34-2.03 Auxiliary Lanes	34-2.6
34-2.04 Curbs and Curbed Sections	34-2.7
34-2.04(a) Warrants	34-2.7
34-2.04(b) Curb Types	34-2.8
34-2.04(c) Curb Type Selection	34-2.8
34-2.04(d) Design Considerations	34-2.13
34-3 MEDIANS	34-3.1
34-3.01 Functions	34-3.1
34-3.02 Median Widths	34-3.1
34-3.03 Median Types	34-3.2
34-3.03(a) Flush Medians	34-3.5
34-3.03(b) Traversable TWLTL Medians	34-3.5
34-3.03(c) Raised-Curb Medians	34-3.6
34-3.03(d) Depressed Medians	34-3.7

34-3.04	Median Selection	34-3.7
34-3.04(a)	General	34-3.7
34-3.04(b)	Urban Median Types.....	34-3.8
34-3.04(c)	Suburban Median Types.....	34-3.8
34-3.04(d)	Rural Median Types.....	34-3.12
34-4	ROADSIDE ELEMENTS	34-4.1
34-4.01	General.....	34-4.1
34-4.02	Fill Sections	34-4.1
34-4.03	Ditch Sections.....	34-4.4
34-4.03(a)	Typical Slope Rates	34-4.4
34-4.03(b)	Material and Soils Conditions	34-4.4
34-4.03(c)	Hydraulic Design.....	34-4.6
34-4.04	Cut Sections With Curbs	34-4.6
34-4.05	Rock Cuts (Back Slopes).....	34-4.6
34-4.06	Roadside Safety	34-4.9
34-4.07	Transverse Slopes.....	34-4.9
34-4.08	Geotechnical Features	34-4.9
34-4.09	Aesthetics	34-4.10
34-5	RIGHT-OF-WAY	34-5.1
34-5.01	General.....	34-5.1
34-5.02	Definitions.....	34-5.1
34-5.03	Establishment of Right-of-Way Lines	34-5.2
34-5.04	Right-of-Way Width	34-5.2
34-5.05	Other Considerations.....	34-5.2
34-6	UTILITIES	34-6.1
34-6.01	Definition.....	34-6.1
34-6.02	Location	34-6.1
34-6.03	Design Considerations	34-6.1
34-7	REFERENCES.....	34-7.1

Chapter Thirty-four

CROSS SECTION ELEMENTS

This Chapter provides guidance to consider in the design of cross section elements including lane and shoulder widths, cross slopes, width and type of medians, side slopes, right-of-way, and utilities. Part V, Design of Highway Types, provides criteria for various cross section elements on new construction, reconstruction, and 3R projects. Where a cross section element applies to a specific highway type, Part V presents this information. For example:

- Cross sectional widths for bridges and underpasses are discussed in Chapter 39.
- Median widths and median openings for freeways and expressways are discussed in Chapters 44 and 45, respectively.
- Typical cross section figures for the various functional classifications are presented in Chapters 44 through 48.
- For definitions on area classifications, see Chapter 43.
- Chapter 48 discusses sidewalk and on-street parking design criteria.
- Cross section criteria for 3R projects are discussed in Chapters 49 and 50.
- For surface type and structural design of pavements, see Chapter 54.

34-1 GENERAL

34-1.01 Definitions

The following definitions apply to the highway cross section:

1. Auxiliary Lane. The portion of the roadway adjoining the traveled way for purposes supplementary to through traffic movement including parking, speed change, turning, storage for turning, weaving, or truck climbing.
2. Back Slope. The side slope created by connecting the ditch bottom, shelf, or shoulder at the hinge point, upward and outward, to the natural ground line.
3. Barrier (Vertical) Curb. A longitudinal element placed at the edge of the traveled way for delineation, to control drainage, to manage access, and to minimize right-of-way acquisitions. Vertical curbs range in height between 6 in (150 mm) and 9 in (225 mm) and are vertical or nearly vertical.
4. Buffer Area. The space between the back of curb and sidewalk.

5. Cross Slope. The slope in the cross sectional view of the traveled way, travel lanes, shoulders, median surface, or gutters, expressed as inch(es) per foot (percent) based on the change in vertical compared to the change in horizontal.
6. Concrete Barrier. A rigid barrier constructed in a narrow median where no or minimal deflection distance is available and which can accommodate most vehicle impacts without penetration.
7. Depressed Median. The area located between opposing directions of the traveled ways which is designed with shoulders and fill slopes and is lower in elevation than the traveled ways. Its main function is to provide a safe distance between opposing traffic. It is also designed to carry a certain portion of roadway drainage and for snow storage.
8. Flush Median. A median which is in the same plane as the surface of the adjacent traveled ways.
9. Front Slope. The side slope created by connecting the shoulder or shelf at the hinge point, downward and outward, to the ditch bottom or natural ground.
10. Hinge Point. The point from which the fill height or depth of cut is determined. For fills, the point is located at the intersection of the shoulder and the fill slope. For cuts, the hinge point is located at the toe of the back slope.
11. Maintenance Border Area. Additional width which is set aside for right-of-way purposes adjacent to each side of the construction limits. This clear width provides an area for maintenance operations, retention of natural growth, erosion control, slope rounding and, in some cases, for accommodating public utilities.
12. Median. The portion of a cross section which separates the opposing directions of the traveled ways. The median width includes the inside shoulders or curb and gutters.
13. Median Slope. The slope in the cross section view of a median beyond the inside shoulders, expressed as a ratio of the change in vertical to the change in horizontal (V:H).
14. Mountable (Sloping) Curb. A longitudinal element placed at the edge of the traveled way for delineation, to control drainage, to manage access, and to outline corner islands. Sloping curbs have a height of 6 in (150 mm) or less with a slope face of approximately 45°.
15. Raised-Curb Median. A median which contains a raised-curb, greater than 2 inches (50 mm) in height, within its limits.
16. Roadside. A general term denoting the area adjoining the outer edge of the roadway.
17. Roadside Clear Zone. The distance beyond the edge of traveled way that should be clear of any non-traversable hazards or fixed objects.

18. Roadway. The combination of the traveled way, both shoulders or curb and gutters, and any auxiliary lanes on the mainline highway. Traveled ways separated by a depressed median have two or more roadways.
19. Shelf. On curbed facilities, the relatively flat area (2% to 5% slope) located between the back of the curb and the break for the fill slope or back slope.
20. Shoulder. The portion of the roadway contiguous to the traveled way for the accommodation of stopped vehicles, for emergency use, and for lateral support of subbase, base, and surface courses.
21. Side Slope. A ratio used to express the steepness of a slope adjacent to the roadway. The ratio is expressed as vertical to horizontal (V:H).
22. Sidewalk. That portion of the highway cross section separated from the roadway and constructed for the use of pedestrians.
23. Toe of Slope. The intersection of the front slope or back slope with the natural ground or ditch bottom.
24. Top of Slope. The intersection of the back slope with the natural ground, before any rounding is applied.
25. Traveled Way. The portion of the roadway for the movement of vehicles, exclusive of shoulders, curb and gutter, and auxiliary lanes.
26. Traversable Median. A median which is outlined with 2 in (50 mm) high mountable curb and gutter and used as a direct substitute for the flush two-way, left-turn lane (TWLTL). It is not designed to be a physical barrier nor is it intended to impede left-turn movements across the median.

34-1.02 Nomenclature

Figures 34-1.A, 34-1.B, and 34-1.C provide the basic nomenclature for cross section elements of freeways and expressways, rural highways, and urban streets.

34-1.03 Classification by Area Type

The functional classification system is divided into urban and rural categories. However, the urban designation is not sufficiently specific to determine the appropriate project design. Therefore, IDOT has divided its urban design classifications into “suburban” and “urban” based on the extent of roadside development. IDOT has further subdivided these categories into central business districts and fringe area/outlying business district for urban areas, and open and closed subcategories for suburban areas. These subcategories are discussed in Chapter 43.

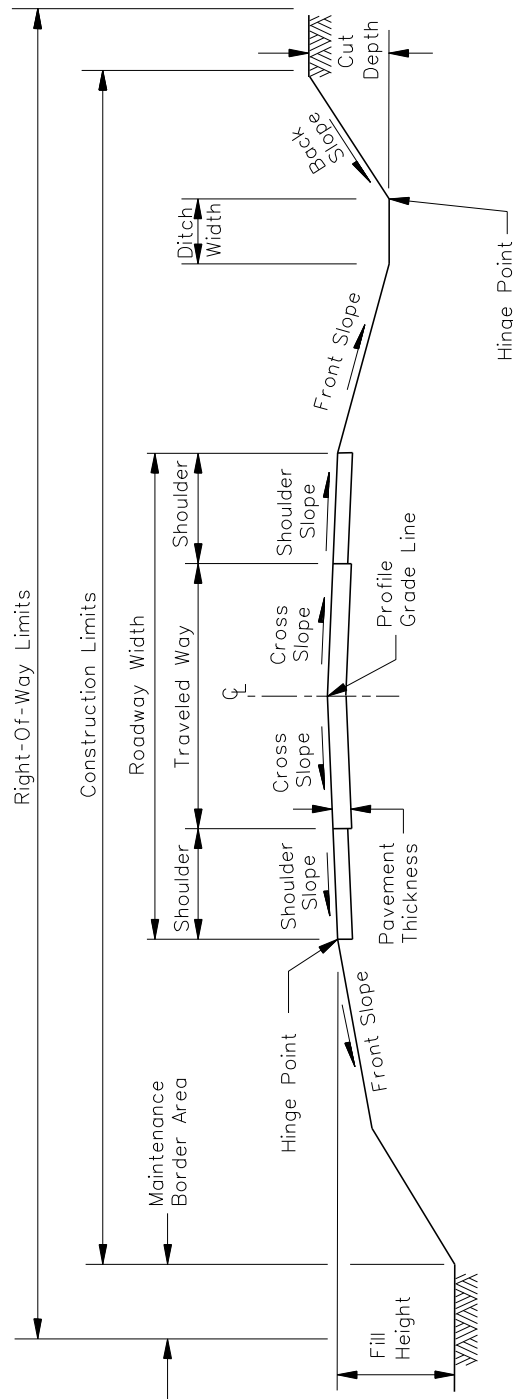

**RURAL HIGHWAY NOMENCLATURE
(Two-Lane Highways)**

Figure 34-1.B

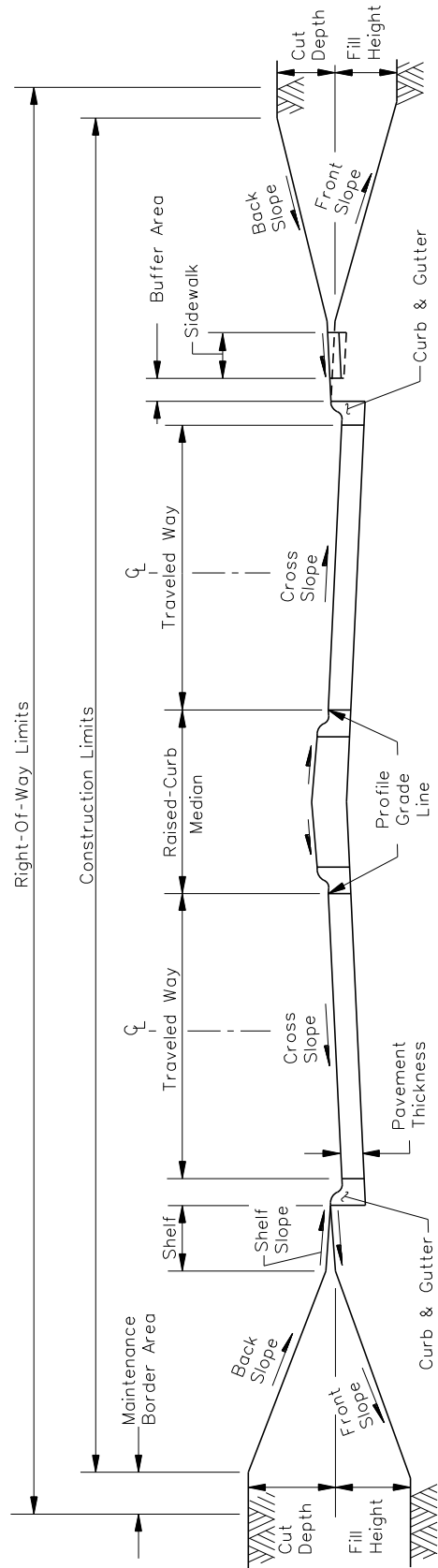

URBAN STREET NOMENCLATURE

Figure 34-1.C

34-2 ROADWAY SECTION

34-2.01 Travel Lanes

34-2.01(a) Width

Travel lane widths can vary between 9 ft (2.7 m) and 14 ft (4.2 m), depending upon the functional classification, traffic volumes, design speed, rural/urban location, and project scope of work. The tables in Chapters 44 through 50 provide specific travel lane widths for these conditions. The traveled way width is the combined width of all travel lanes. For divided highways, the traveled way width is the combined width in one direction.

The use of wider travel lanes generally increases the operational safety and efficiency of the facility. In general, 12 ft (3.6 m) wide travel lanes are preferable for most rural and high-speed urban facilities. Lane widths of 11 ft (3.3 m) are acceptable for restricted urban areas and may be considered on reconstruction projects. Lane widths may need to be increased to accommodate bicycles, see Chapter 17.

34-2.01(b) Cross Slopes

Surface cross slopes are required for proper drainage of the traveled way on tangent sections. A sufficient cross slope reduces the hazards of wet pavements by quickly removing water from the surface. On State highways, the following will apply for tangent roadway sections:

1. Two-Lane Highways with Shoulders. Crown the traveled way pavement at the centerline and use a cross slope of $3/16$ "/ft (1.5%) away from the centerline. Where an open-graded friction course is used, the minimum cross slope should be $1/4$ "/ft (2%).
2. Two-Lane Curbed Streets. Crown the traveled way pavement at the centerline and use a cross slope of $1/4$ "/ft (2%) away from the centerline.
3. Multilane Curbed Streets. On multilane streets with raised-curb medians, the pavement cross slope of a two-lane traveled way should be $1/4$ "/ft (2%) sloping away from the median curb. If there are three lanes in one direction, provide a $5/16$ "/ft (2.5%) cross slope on the third lane from the median curb.
4. Multilane Streets with a Traversable Curbed Median. The traveled way cross slopes are the same as discussed in Item 3 above. Crown the traversable median surface at the centerline of the median and use a cross slope of $3/16$ "/ft (1.5%) away from the centerline.
5. Four-Lane Streets with a Flush Median. Crown the entire paved surface of the roadway about the centerline of the flush median and use a cross slope of $1/4$ "/ft (2%) away from the centerline to the outside curb and gutter.
6. Highways without Curbed Medians. For roadways divided by a median, the following cross slopes will apply:

- a. Two-Lane Traveled Ways. For highways with two lanes in each direction and either a depressed median or narrow median with a concrete barrier, each traveled way is crowned at its centerline with a cross slope of 3/16"/ft (1.5%) sloping away from the centerline.
- b. Three-Lane Traveled Ways (New Construction/Reconstruction). For highways with three lanes in each direction and either a depressed median or a narrow median with a concrete barrier, the traveled way is typically crowned along the lane edge between the middle lane and outside lane. The inside and middle lanes are sloped towards the median. The two lanes adjacent to the crown are sloped at 3/16"/ft (1.5%) away from the crown line and the lane adjacent to the median is sloped at 1/4"/ft (2%) toward the median.
- c. Three- or Four-Lane Traveled Ways (Adding Lanes to Existing Facilities). When adding new lanes in the median or on the outside of the traveled way, the existing crown is typically maintained. The added travel lane cross slope generally will be the same direction as the adjacent lane. The rate of cross slope for each added lane will be 1/16"/ft (0.5%) steeper than that of the adjacent lane, but not greater than 5/16"/ft (2.5%). See Chapter 44 for typical sections.

For service drives, access roads, side roads, frontage roads, etc., the traveled way cross slopes will vary depending upon the pavement surface and local practices. For paved surfaces (including chip seal), the cross slope is generally the same as for State highways (i.e., 3/16"/ft (1.5%)). For gravel surfaces, the cross slopes can range from 1/4"/ft to 1/2"/ft (2% to 4%).

34-2.01(c) Stage Construction

The 30th highest hourly traffic volumes, measured 10 years from the anticipated date of construction, may be significantly less than those for the design year (e.g., 20 years) such that initial construction may consist of one less lane in each direction. In this case, the designer may want to consider using stage construction. For rural expressways, this may initially include only providing one roadway of the four-lane divided facility. In urban areas, this may initially include only providing four lanes instead of six. For these situations, sufficient right-of-way for the ultimate improvement should be acquired at the time of the initial improvement. See the Corridor Preservation section in the *IDOT Land Acquisition Policies and Procedures Manual* for additional guidance. For urban facilities, also include the appropriate earthwork and consideration for placement and sizing of drainage structures in the initial construction to allow for the additional lanes in the median area in the future.

34-2.02 Shoulders

34-2.02(a) Functions

Shoulder widths can vary between 4 ft (1.2 m) to 12 ft (3.6 m) depending upon the highway classification. They also provide many structural and operational advantages. Where shoulders

are not available, a stopped vehicle often disrupts traffic in all lanes in that direction. The following are some of the important functions of shoulders:

- provides structural support for the traveled way;
- provides support for guardrail and prevents erosion around guardrail posts;
- prevents or minimizes pavement edge dropoffs;
- increases highway capacity;
- encourages uniform travel speeds;
- provides space for emergency and discretionary stops;
- improves roadside safety by providing more recovery area for run-off-the-road vehicles;
- provides lateral clearance for encroaching vehicles (e.g., during construction or maintenance operations);
- provides a sense of openness;
- improves sight distance around horizontal curves;
- enhances highway aesthetics;
- facilitates maintenance operations (e.g., snow removal and storage);
- provides additional lateral clearance to roadside appurtenances (e.g., guardrail, parapet walls, traffic signals, highway signs);
- facilitates pavement drainage, water is discharged farther from the traveled way;
- provides space for pedestrian and bicycle use; and
- provides space for bus stops and mailbox turnouts.

34-2.02(b) Widths

Shoulder widths will vary according to functional classification, traffic volumes, urban/rural location, curbed/uncurbed, and the project scope of work. The tables in Chapters 44 through 50 present the shoulder width criteria for these conditions. A vehicle stopped on the shoulder should clear the traveled way edge by at least 1 ft (300 mm) and preferably 2 ft (600 mm). Therefore, a width of 8 ft (2.4 m) is desirable along high-type facilities to accommodate passenger vehicles and 10 ft (3.0 m) for trucks. Where bicyclists will be accommodated, see Chapter 17 for guidance.

Where right-of-way is severely restricted, shoulders may be designed with a curb and gutter or a Type B gutter at the outer shoulder edge. This helps to minimize construction costs and to confine drainage runoff to the shoulder area. Gutters also may be used on the outside of shoulders along long cut sections.

34-2.02(c) Additional Shoulder Thickness

For all new construction or reconstruction projects on the State system, increase the shoulder pavement thickness to allow the shoulders to be used to carry traffic during current and future construction improvements. Design the shoulder pavement using the following guidelines:

1. 2-Lane Major Principal Arterials. These highways should normally have 8 ft to 10 ft (2.4 m to 3.0 m) paved shoulders. These shoulders could be used to carry traffic when needed. When the 20-year projected traffic exceeds 2000 multiple unit trucks (MU) per day or 10,000 Average Daily Traffic (ADT), construct the shoulders to the same thickness as the traveled way pavement. The 2000 MU threshold is based on the traffic that would require a shoulder thickness greater than 8 in (200 mm) to handle the occasional load.
2. 4-Lane Highways. When the 20-year projected traffic exceeds 3000 MUs per day or 25,000 ADT, design the shoulders pavement using the same thickness as the adjoining traveled way pavement. The MU threshold is based on the traffic that would require thicker pavement to carry the load. While the inside shoulder is only 6 ft (1.8 m) wide and would not normally be used as a lane, it will still allow traffic to be shifted away from the closed lane for patching and paving operations. At locations where the 20 year projected ADT is less than 25,000, the traffic should be examined at peak times. If the expected one-way Vehicles Per Hour (VPH) exceeds 1700, design the shoulder pavement using the same thickness as that of the adjacent traveled way pavement. Where it is anticipated that the shoulders will be used for an extended period of time (more than 3 years) during the design life of the pavement, design the shoulder pavement using the same pavement design, details, and materials as the traveled way pavement.
3. Highways of 6 or More Lanes. Build all shoulder pavements using the same pavement design, details and materials as the traveled way pavement. This will allow for keeping at least two, and in some cases, three lanes open at all times, as warranted by the high ADT on these types of highways.

34-2.02(d) Cross Slopes

The cross slope of a shoulder depends on the type of shoulder and the construction project type. The following summarizes typical practices:

1. Paved Shoulders. On new construction projects, full-width paved shoulders on tangent sections are sloped at 1/2"/ft (4%). On reconstruction and 3R projects, the shoulder slopes range from 1/4"/ft to 3/4"/ft (2% to 6%).
2. Combination Shoulders. Combination paved/aggregate shoulders are sloped at 1/2"/ft (4%).
3. Aggregate Shoulders. Aggregate shoulders are sloped from 1/2"/ft to 3/4"/ft (4% to 6%).
4. Sodded Shoulders. Sodded shoulders are sloped from 5/8"/ft to 1"/ft (5% to 8%).
5. Superelevated Sections. Chapter 32 and the *IDOT Highway Standards* discuss the application of shoulder cross slopes on superelevated sections for new construction and reconstruction projects. For allowable shoulder rollover values on 3R projects, see Chapters 49 and 50.

34-2.02(e) Rumble Strips

1. Shoulder Rumble Strips. Shoulder rumble strips are an effective way to reduce run-off-the-road crashes. They provide a very cost effective means of alerting motorists that they have drifted off the pavement. The greatest benefit is from the installation of milled rumble strips on rural expressways, freeways, and other facilities in which a significant number of run-off-the-road crashes occur.

Shoulder rumble strips shall be:

- installed on all Interstates and other freeways built to Interstate criteria and on all rural expressways with posted speeds > 50 mph (80 km/h);
- installed along all highways that have high-crash locations, as identified in the Bureau of Safety Engineering's Highway Safety Improvement Program (HSIP), in which run-off-the-road crashes are a concern and have an adequate paved shoulder width; and
- considered at other locations where run-off-the-road crashes are a concern.

On facilities in which bicyclists are prohibited or the paved shoulders are wider than 6 ft (1.8 m), the 16 in (400 mm) rumble strip design should be used. On facilities in which bicyclists are permitted and the paved shoulder width is 6 ft (1.8 m) or less, the 8 in (200 mm) rumble strip design should be used to maximize the clear shoulder width available for cyclists. See Section 17-2.02(a) for a discussion of bicycle accommodations utilizing paved shoulders.

Milling is the preferred method for installing rumble strips; however a formed-in option is allowed for installing the 16 in (400 mm) rumble strips in Portland Cement Concrete shoulders. When the shoulder will be used for traffic during construction, the formed-in option should be reviewed and not allowed if conflicts will occur. It may also be

necessary to specify when the milled shoulder rumble strips may be installed if they conflict with the staging of traffic.

2. Centerline Rumble Stripes. The primary purpose of centerline rumble stripes (CLRS) is to warn drivers whose vehicles are crossing the centerline of two-lane, two-way roadways (and, in some cases, four-lane undivided highways) to avoid potential crashes with opposing traffic.

CLRS address the problem of drowsy or inattentive drivers drifting left out of their lane and striking an oncoming vehicle. Two types of crashes are generally considered correctable by CLRS — head-on and opposite-direction sideswipes often referred to as cross-over or cross-centerline crashes.

The use of CLRS can be an effective countermeasure on roadways where there are a high number of crashes with opposing traffic. Consult with the Bureau of Safety Engineering if CLRS are being considered for the project. BSE will provide details for the CLRS.

3. Shoulder Rumble Stripes. Shoulder rumble stripes are similar to shoulder rumble strips, but include an edge line pavement marking installed within the rumble strip. There is evidence that shoulder rumble stripes provide a better wet pavement marking and actually provide a more durable pavement marking than just a regular flat pavement marking. Shoulder rumble stripes are considered an experimental feature. Consult with the Bureau of Safety Engineering for further guidance on their use.

34-2.03 Auxiliary Lanes

Auxiliary lanes are lanes adjacent to the basic through traveled way. They are intended for use by vehicular traffic for specific functions. Auxiliary lanes include:

- single left- and right-turn lanes at intersections;
- double left-turn lanes at intersections;
- truck-climbing lanes;
- acceleration/deceleration lanes at interchanges or intersections;
- weaving lanes within an interchange;
- continuous auxiliary lanes between two closely spaced interchanges;
- two-way, left-turn lanes (TWLTL) (flush-type median);
- parking lanes; and
- passing lanes.

Desirably, auxiliary lanes should be the same width as the adjacent through lanes, although in many cases a greater or lesser width may be appropriate. The tables in Chapters 44 through 50 present specific width criteria for auxiliary lanes and curb type or shoulder widths adjacent to auxiliary lanes.

Normally, the rate of cross slope for an auxiliary lane will be 1/16"/ft (0.5%) steeper than that of the adjacent through lane except for curbed left-turn lane and TWLTL. Single left-turn lanes with curb and gutter are usually sloped at 1/8"/ft to 3/16"/ft (1.0% to 1.5%) away from the median to allow for snow plowing. TWLTL and flush left-turn lanes are crowned at the centerline and sloped at 1/4"/ft (2%) in each direction.

34-2.04 Curbs and Curbed Sections

Curbs are used on urban and suburban facilities due to restricted right-of-way conditions and to control drainage, delineate pavement edges, channelize vehicular movements, manage access, provide separation between vehicles and pedestrians, and present an attractive appearance. In urban areas, curbs have a major benefit in containing the drainage within the pavement area and in channelizing or controlling traffic into and out of adjacent properties. In rural areas, curbing may be applicable where restricted right-of-way prohibits the use of a ditch section, or to channelize traffic at isolated intersections.

34-2.04(a) Warrants

Selecting a curbed section or section with shoulders and outside ditches depends upon many variables, including vehicular speeds, urban/rural location, drainage, and construction costs. The following discusses some of the factors the designer should consider when determining whether or not a curbed section is warranted:

1. Urban Location. Because of restricted right-of-way, the need to control drainage, and other constraints, curb and gutter sections on the outside edges of the traveled way are almost always used in urban areas.
2. Suburban Location. The use of curbs and/or gutters will depend upon whether the suburban area is considered closed or open. Section 43-2 defines open and closed suburban areas. For closed suburban areas, the street will have outside curb and gutter sections based on drainage requirements, pedestrian activities, channelization needs, and the desire to manage access to the street. For open suburban areas, the outside edge of the traveled way may have either shoulders or curb and gutter depending on the proposed median type and the preferred design speed. The exceptions listed under Item 3 for rural locations also apply to open suburban streets.
3. Rural Location. In general, the use of mountable type curbs and/or gutters along rural high-speed highways is limited to the edge of shoulder and to the following special conditions:
 - for roadway delineation in conjunction with channelization at intersections;
 - where there is sufficient development along the highway and there is a need to channelize traffic into and out of properties;
 - where drainage control is required;

- where right-of-way is restricted for roadside ditches; and/or
- at other sites deemed necessary (e.g., interchange crossroads, major intersections with restricted sight distance, where the route turns, offset left-turn lanes).

34-2.04(b) Curb Types

IDOT uses two basic types of curbs – barrier (vertical) and mountable (sloping). The *IDOT Highway Standards* provide information on design details and placement for various curb types used by the Department. For most situations, an integral concrete curb and gutter (CC&G) is used. The following notations are used by the Department to define the various curb types (e.g., M-10.60):

1. Initial Letter. The initial letter “B” or “M” is used to denote whether the curb is barrier (vertical) type or mountable (sloping) type.
2. Numbers Prior to the Decimal Point. The first set of numbers indicates the height of the curb in inches (centimeters).
3. Numbers After the Decimal Point. The second set of numbers, if used, indicates the width of the gutter in inches (centimeters).

34-2.04(c) Curb Type Selection

The designer should consider the following factors when selecting a curb type:

1. Low-Speed Facilities (Outside Edge of Traveled Way). Where the design speed is 45 mph (70 km/h) or less, use B-6.24 (B-15.60) CC&G along the right edge of the traveled way or parking lane. A lesser gutter width may be used adjacent to a right-turn lane, parking lane, or where highly restricted right-of-way conditions exist.
2. High-Speed Facilities (Outside Edge of Shoulder). Where a high-speed facility (≥ 50 mph (80 km/h)) is proposed with shoulders and side slopes, there may be occasional locations where the right-of-way is restricted. In these cases, use an M-4 (M-10) curb and gutter along the right edge of the shoulder. Do not place curb and gutter immediately adjacent to the edge of the traveled way.
3. Pedestrians. In urban and suburban areas, consider the use of B-9 (B-22) curb along the right edge of the traveled way where some additional protection is desired for pedestrians (e.g., adjacent to school yards, playgrounds). Use the B-9 (B-22) curb on sidewalks across bridges. Where the B-9 (B-22) curb is used, the design speed on the street should be 45 mph (70 km/h) or less. The gutter width may vary depending on drainage requirements or type of lane; however, the preferred gutter width is 2 ft (600 mm).

4. Two-Lane Facilities (Raised-Curb Median). Use M-4 (M-10) curb with a preferred gutter width of 6 in (150 mm) on two-lane approaches where curbed channelization is required and where the design speed is 50 mph (80 km/h) or greater. This may include some rural intersections and all channelizing islands through rural interchange areas.
5. Multi-Lane Facilities (Raised-Curb Median). The main function of a raised-curb median is to manage access to and from the street or to channelize traffic. The following will apply:
 - Use M-6.24 (M-15.60) CC&G on channelizing islands and medians where the design speed is 30 to 40 mph (50 or 60 km/h).
 - Use B-6.24 (B-15.60) CC&G on channelizing islands and medians where the design speed is 40 or 45 mph (60 or 70 km/h).
 - For the design speed of 40 mph (60 km/h), the designer has the option to use either an M-6 or B-6 (M-15 or B-15) curb depending upon the aggressiveness of drivers in a particular area and upon the 85th percentile speeds of similar type streets in the area.
 - Use M-4 (M-10) curb on channelizing islands or medians where the design speed is 50 mph (80 km/h) or greater. Typically, curbing is only used at locations that would be channelized (e.g., offset left-turn lanes), near at-grade intersections where a concrete barrier is terminated, or on the crossroad through an interchange. Section 36-4 provides additional details for curbing at intersections.
 - Where posted speeds will exceed 45 mph, raised-curb medians are generally not considered an appropriate type of median cross section.
6. Traversable Medians. Use M-2.12 (M-5.30) CC&G where there is a need to provide a continuous two-way, left-turn lane (TWLTL) along the street and where raised delineation of the center turn lane is desirable. This is usually applicable only in major metropolitan areas where painted or thermoplastic turn lanes are quickly worn by vehicular use and maintenance of such pavement markings is a potential hazard to striping crews. The traversable TWLTL median should be marked with directional turn arrows to enhance proper traffic operations. See Figure 48-4.B for a typical traversable TWLTL detail.
7. Corner Islands. On streets or highways with a design speed of 45 mph (70 km/h) or less, use the M-6 (M-15) curb on all corner islands. On facilities with design speeds of 50 mph (80 km/h) or greater, the following will apply relative to corner islands and traffic signals:
 - Where traffic signals are not proposed, use an M-4 (M-10) curb with a specified gutter width on all corner islands adjacent to the high-speed facility.

- Where traffic signals are present or proposed, use an M-6 (M-15) curb with a specified gutter width on corner islands adjacent to high-speed facilities.
8. Freeway Over Crossroad. Figure 34-2.A illustrates part of a diamond interchange where an existing freeway overpasses the crossroad. In this case, it may be necessary to place a pier in the crossroad channelization, or a pier may already exist in the median. Under these circumstances, and if the design speed is 50 mph (80 km/h) or greater, the bridge pier will require shielding with an impact attenuator. For this situation, use an M-4 (M-10) curb as shown in Figure 34-2.A and reduce the curb height to an M-2 (M-5) curb for a minimum of 30 ft (9 m) in front of the attenuator. This special condition could occur on either a two-lane or multilane channelized cross section where the design speed is 50 mph (80 km/h) or greater.
 9. Special Median Conditions. There are certain special conditions where the median curb selection in the above guidelines is not appropriate. These may include:
 - a. Railroads. Where a highway approaches an at-grade railroad crossing and the design speed is 45 mph (70 km/h) or less, provide B-6.24 or B-9.24 (B15.60 or B-22.60) CC&G along the median edges for a short distance adjacent to the crossing. This barrier curb type will discourage motorists from driving around the railroad gates. See Figure 7-3.E for guidance.

Where a highway departs an at-grade railroad crossing and the design speed is 45 mph (70 km/h) or less, provide M-4 (M-10) CC&G along the median edges for a short distance adjacent to the crossing. When the design speed is 50 mph (80 km/h) or greater, provide M-2 (M-5) CC&G. These mountable curb types will provide an escape area for vehicles. See Figure 7-3.E for guidance.
 - b. Median Piers. Where a street approaches a bridge pier in the median island and the design speed is 45 mph (70 km/h) or less, a B-9.24 (B-22.60) CC&G may be used along the median edges for a short distance adjacent to the pier.
 - c. Bridge Decks (Icing). In areas of the State where bridge decks are subject to frequent icing and where curbed medians are proposed, either the B-6 or B-9 (B-15 or B-22) curb may be used on the bridge deck median depending on the proposed design speed of the street. The B-6 (B-15) may be used with 30 to 40 mph (50 or 60 km/h) design speeds and the B-9 (B-22) for 40 or 45 mph (60 or 70 km/h) design speeds.
 - d. Curbed Medians on Bridge Decks. Where a center channelizing island is used on a rural high-speed highway (e.g., on the crossroad through an interchange), use the B-6 (B-15) curb rather than the M-2 (M-10) curb across the structure. Because the curbed median is doweled to the completed bridge deck, the 6 in (150 mm) height and barrier face of the curb is needed for proper attachment to the deck and for long-term stability of the concrete median.

- e. Other Uses. Where landscaping, traffic control devices, or light standards are located in the median, B-6.24 (B-15.60) CC&G may be used on the median.

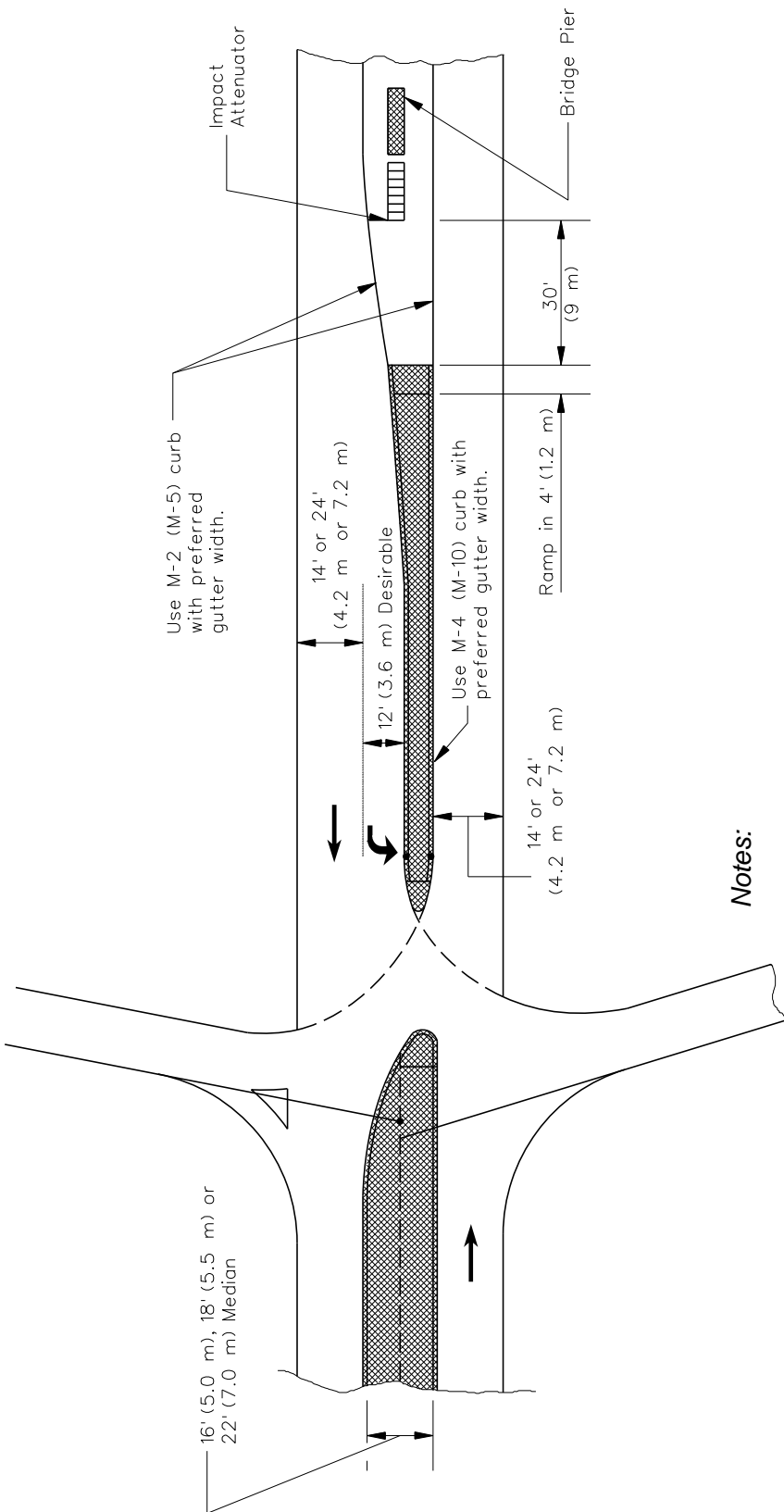

Notes:

- The design speed on crossroad is 50 mph (80 km/h) or greater.
- With 2 @ 14 ft (4.2 m) wide through lanes and an 18 ft (5.5 m) wide median, use an M-4.6 and M-2.6 (M-10.15 and M-5.15) CC&G.
- With 2 @ 24 ft (7.2 m) wide through lanes and a 22 ft (7.0 m) wide median, use an M-4.24 and M-2.24 (M-10.60 and M-5.60) CC&G.

**FREEWAY OVER CROSSROAD
(Existing Interchange)**

Figure 34-2.A

34-2.04(d) Design Considerations

The use of a curbed section requires the consideration and implementation of many design elements. The following discussion includes the major design considerations:

1. Drainage. Water ponding on the traveled way should be limited by using a closed drainage system. A complete hydraulic analysis will consider the pavement cross slopes adjacent to the gutter, the gutter slope, shape of the curb face, and the gradeline of the gutter. See Chapter 40 in the *BDE Manual* and the *IDOT Drainage Manual* for specific criteria and procedures for drainage analysis.
2. Cross Slopes. Where an integral curb and gutter section is used, the gutter has a steeper cross slope, typically 3/4"/ft (6%), than the adjacent pavement surface. For curb and gutter sections along the outside of the roadway, the gutter is sloped away from the roadway. For raised-curb medians, the direction of slope for the gutter will depend upon the width of the median. Section 34-3.03(c) discusses this criteria.
3. Gutter Width. Where cross section space is critical, the normal gutter width adjacent to the left edge of a left-turn lane or right edge of a right-turn lane may be narrowed or eliminated adjacent to 12 ft (3.6 m) lanes and narrowed adjacent to 11 ft (3.3 m) lanes.
4. Design Speed. Relative to curbing and design speeds, the following will apply:
 - a. High Speed. Facilities with high design speeds (≥ 50 mph (80 km/h)) should not be designed with continuous curbs. However, if necessary for drainage, a mountable curb may be used if it is placed at the outside shoulder edge.
 - b. Low Speed. Depending on the specific conditions, streets may be designed with either a mountable or barrier curb. Curb and gutters may be placed at the edge of the traveled way.
5. Running Speeds. Curb and gutter is used along the outside edges of traveled ways in urban areas because of restricted right-of-way, to contain drainage, and to provide for access management. In addition, the more compact cross section of outside curb and gutter tends to provide motorists with a subtle message of restricted space. Consequently, there is a tendency to travel at a lower running speed than the posted speed. This is especially true in open and closed suburban areas.
6. Vehicular Encroachment. Where sidewalks, roadside appurtenances, etc., are present, it is desirable to minimize the probability of vehicular encroachment beyond the curb. Although no curb type will prohibit encroachments, barrier curbs tend to discourage motorists from driving too close to the curb. Note that barrier curbs are not used on facilities with design speeds of 50 mph (80 km/h) or greater.
7. Roadside Safety. When examining curbs relative to roadside safety, the designer should review Chapter 38 for clear zone and roadside barrier guidance.

8. Transitions. Figure 34-2.B illustrates two situations where a shoulder section is transitioned to a curbed section.
9. Driveways. The IDOT *Policy on Permits for Access Driveways to State Highways* presents the design details for the use of curbs at driveways. Also review Section 36-7.
10. Mail Delivery. In many cases where a roadway is changed from a rural cross section with shoulders to a curb and gutter section (e.g., through a small town or adjacent to the urban development of a city), the designer must consider how the curb and gutter might affect mail delivery. One option requires the construction of mailbox turnouts along the street. Another is the construction of a continuous 6 ft (1.8 m) shoulder with a curb and a 2 ft (600 mm) gutter behind the shoulder. See Chapter 58 for design details.
11. Disabled Accessibility. Curbs shall be designed with sidewalk ramps at all pedestrian crosswalks to provide access for the safe and convenient movement of physically disabled individuals. Chapter 58 and the *IDOT Highway Standards* provide details on the design and location of sidewalk ramps.
12. Parking Considerations. Curb heights adjacent to on-street parking should be 6 in (150 mm) or less. If a 9 in (225 mm) curb height is used, provide a wider gutter width. Curb heights on streets and parking lots with diagonal or perpendicular parking should be limited to a 6 in (150 mm) maximum height.

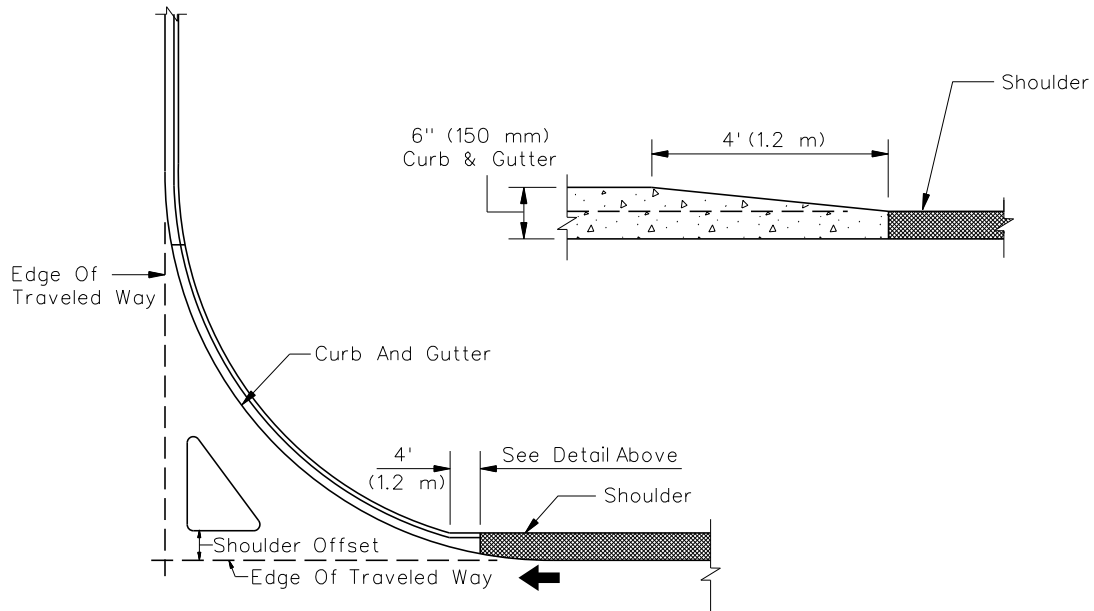
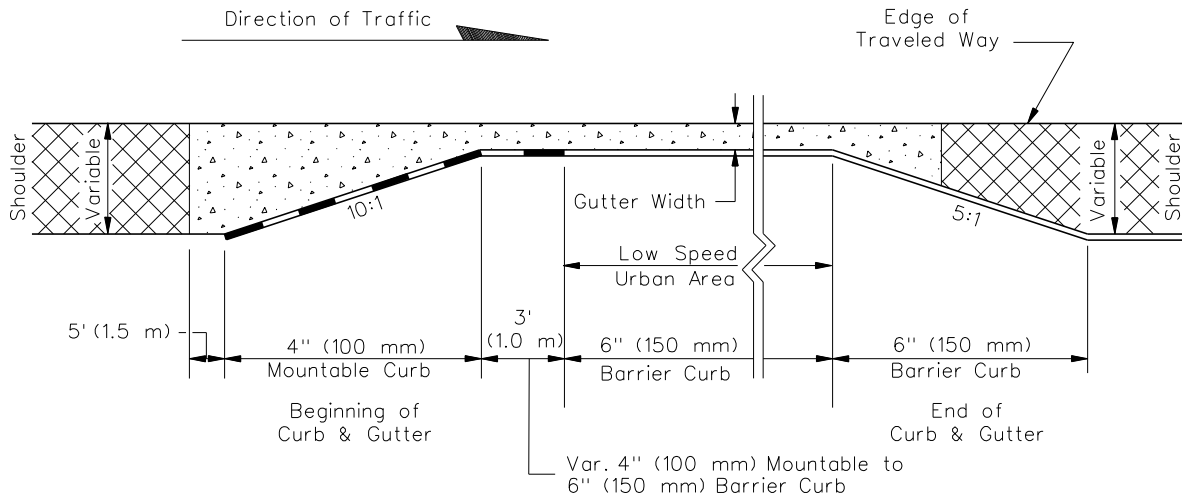

CURB TRANSITIONS

Figure 34-2.B

34-3 MEDIANS

34-3.01 Functions

A median is defined as the portion of a cross section that separates the opposing directions of the traveled ways. The principal functions of a median are:

- to provide a separation between opposing traveled ways;
- to provide a recovery area for out-of-control vehicles;
- to provide a storage area for emergencies;
- to prevent undesirable turning movements (manage access to the highway), provided the median is non-traversable;
- to provide areas for deceleration and storage of left-turning and U-turning vehicles;
- to minimize headlight glare;
- to provide an area for storage of vehicles crossing the mainline highway at intersections;
- to facilitate drainage and snow collection (raised-curb or depressed medians);
- to permit the use of shorter span lengths for overhead structures;
- to provide an area for pedestrian refuge (raised-curb median); and
- to provide width for future expansion of the roadway.

34-3.02 Median Widths

Median widths should be based upon economic, operational, and environmental considerations. The median width is measured from the inside edge of the two traveled ways and includes both inside shoulders and/or median curb and gutters. A median must be at least 4 ft (1.2 m) wide to meet the minimum functional requirements; however, this minimum width is not used on State highways. Section 34-3.03 presents several median schematics which define the width for the basic median types. The design width will depend on the functional class of the highway, design speed, type of access management proposed, availability of right-of-way, construction costs, maintenance considerations, acceptable median slopes, the anticipated ultimate development of the facility, operations at crossroad intersections, and field conditions. Chapters 44 through 48 present specific numerical criteria for median widths on new construction and reconstruction projects for arterial highways. In addition, the designer should consider the following:

1. Unsignalized Intersections. In urban areas, curbed median widths preferably should be a minimum of 22 ft (7.0 m) to safely allow a crossing passenger vehicle to stop between

- the two traveled ways. In rural areas where trucks and/or buses are commonly present (e.g., truck terminals, light industrial), depressed median widths of 60 ft to 65 ft (18 m to 19 m) are recommended to allow trucks to stop between roadways.
2. Signalized Intersections. Wide medians may lead to increased clearance times and inefficient traffic operations at signalized intersections.
 3. Median Barriers. With narrow medians, a median barrier may be warranted. See Section 38-7. Desirably, select a median width which will be wide enough to eliminate the need for a barrier.
 4. Operations. Several vehicular maneuvers at intersections are partially dependent on the median width of the mainline highway (e.g., U-turns, left turns). Evaluate these likely maneuvers at intersections and provide a median width that will accommodate the selected design vehicle. Also, consider the need for single or dual left-turn lanes. For more information on designing intersections, see Chapter 36.
 5. Uniformity. In general, a uniform median width is desirable. However, variable-width medians may be advantageous where right-of-way is restricted, intersections are widely spaced (3000 ft (1 km) or more), and/or where independent alignments are practical.
 6. Sight Distance. Where a median barrier is proposed at a horizontal curve, the median width may be a factor in whether or not adequate sight distance is available around the horizontal curve. Section 32-4 discusses horizontal sight distance.
 7. Separation. Median widths of 40 ft (12 m) or greater, from the driver's perspective, are considered to be physically and psychologically separated from the opposing traffic.
 8. Maintenance. If glare screens, light poles, or other appurtenances are placed on a median barrier, use a 22 ft (7.0 m) wide median. This provides sufficient clearance for emergency or maintenance vehicles to stop on the shoulders without blocking the traveled way.

34-3.03 Median Types

Figure 34-3.A provides typical sections for various median type — flush, flush with concrete barriers, traversable TWLTL and depressed. Figure 34-3.B provides illustrations of raised-curb medians.

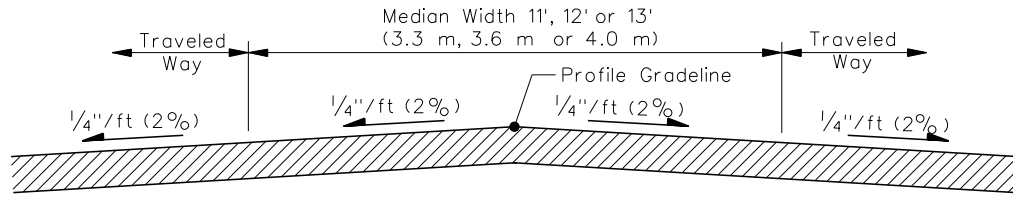

FLUSH MEDIAN
PAINTED LEFT-TURN LANES
OR TWLTL

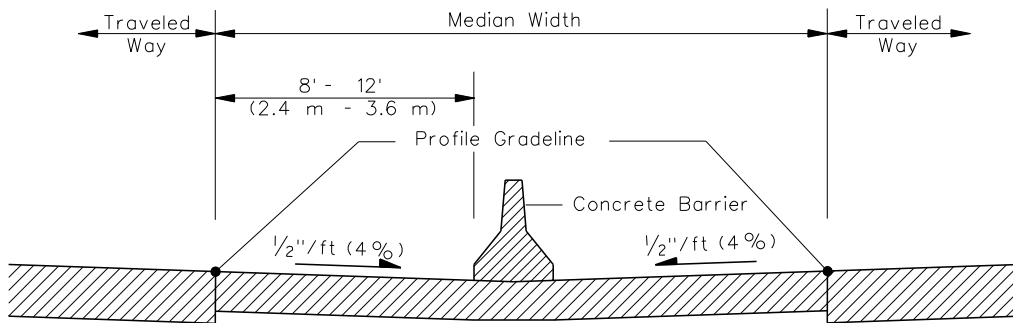

FLUSH MEDIAN
WITH CONCRETE BARRIER

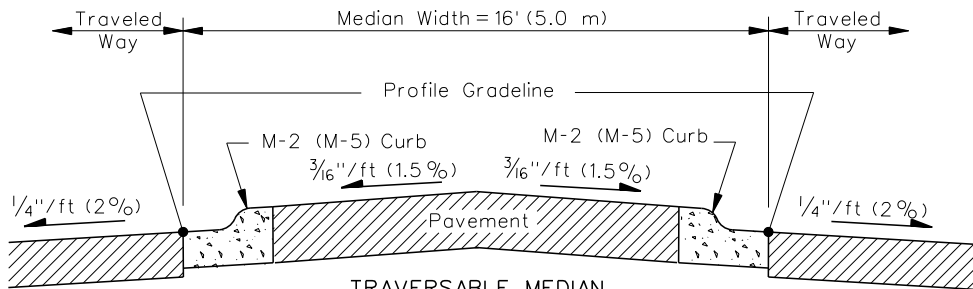

TRAVERSABLE MEDIAN

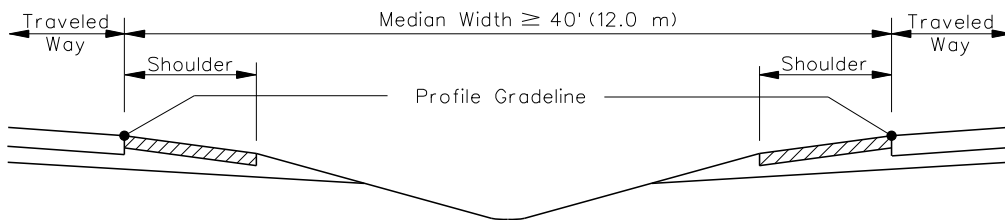

DEPRESSED MEDIAN

**TYPICAL MEDIAN TYPES
(Flush/Traversable/Depressed)**

Figure 34-3.A

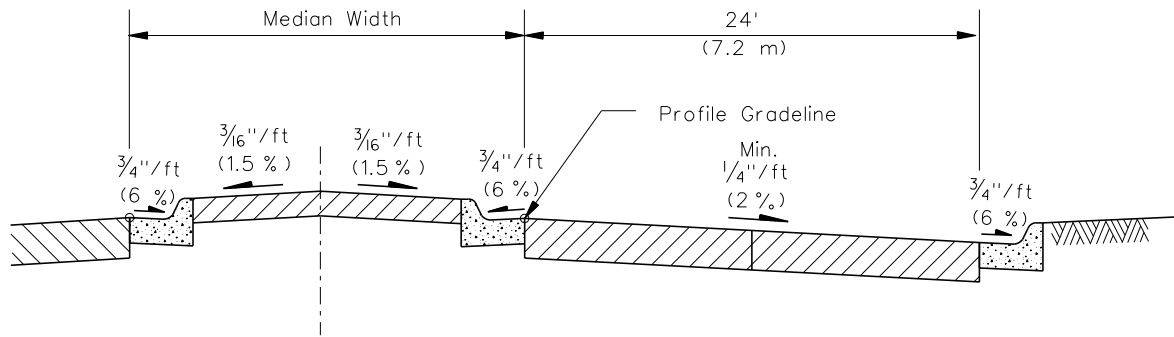

(A) MEDIAN WIDTH 16' TO 22' (5.0 m TO 7.0 m)

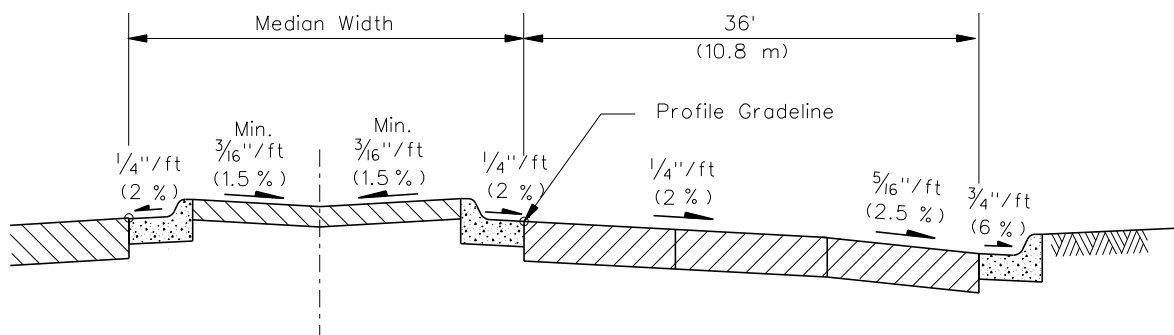

(B) MEDIAN WIDTH > 22' (7.0 m)

**MEDIAN TYPES
(Raised-Curb Medians)**

Figure 34-3.B

34-3.03(a) Flush Medians

A flush median is defined where the surface is constructed as a smooth plane in conjunction with the adjacent roadway pavement. Flush medians are used most often on low-speed urban highways and streets. This flush type median should be slightly crowned to avoid ponding water in the median area. However, with high-speed conditions, flush medians can also be used with the placement of concrete barriers. In this case, the flush median should be depressed to collect water within a closed drainage system. The following discusses the various types of flush medians:

1. Flush. Typical widths for a flush median on an urban street can range from 4 ft (1.2 m) to 13 ft (4.0 m). To accommodate a separate left-turn lane, a flush median should desirably be 13 ft (4.0 m) wide. This will allow for either a 11 ft (3.3 m) or 12 ft (3.6 m) turn lane and a minimum separation of 2 ft (700 mm) or 1 ft (400 mm), respectively, between left-turning vehicles and the opposing traffic.
2. Two-Way Left-Turn Lanes (TWLTL). TWLTL are also considered flush medians. Design criteria, advantages, and disadvantages of a TWLTL are discussed in Chapter 48. Note that where a TWLTL is used, provide curb and gutter along the outside edges of the traveled way. Operating speeds, truck and bus volumes, number and spacing of entrances and intersections, availability of right-of-way, character of abutting property, parking facilities, etc., should be considered when determining appropriate TWLTL lane widths for specific projects.

The usual design widths are 11 ft (3.3 m), 12 ft (3.6 m) or 13 ft (4.0 m). There is some evidence that wide TWLTL lanes encourage drivers to place their vehicles in an angular rather than parallel turning position and thereby cause encroachments on adjacent through lanes. Therefore, maximum widths for flush TWLTL medians should be 13 ft (4.0 m).

3. Flush with Concrete Barrier. A flush median with a concrete barrier may be used on urban freeways and expressways where the right-of-way does not allow for the use of a depressed median. For new construction and reconstruction projects, the minimum width of a flush median for an urban freeway is 20 ft (6.0 m). This allows for the use of two 8 ft (2.4 m) wide left shoulders and provides space for the width of the concrete barrier.

34-3.03(b) Traversable TWLTL Medians

Where an M-2 (M-5) curb is used to delineate the edges of a median, this median is designated as a traversable median and traffic is allowed to turn left across the median. On certain streets in large metropolitan areas where traffic volumes and mid-block left turns are unusually high, the traversable median with an M-2.12 (M-5.30) CC&G, although having a slightly higher initial cost than a flush TWLTL median, may be the appropriate design option. This median type eliminates the frequent and somewhat hazardous striping operations and yet provides for TWLTL movements. Because the traversable TWLTL median was developed as a direct

substitute for the flush TWLTL, the M-2.12 (M-5.30) CC&G is not designed to be a physical barrier nor is it intended to impede left-turn movements across the median.

The normal traversable TWLTL median width for new construction is 16 ft (5.0 m). Existing traversable medians are 16 ft (4.87 m) wide. As discussed for the flush TWLTL, wide traversable TWLTL medians also may encourage drivers to store in an angular position. Therefore, wider widths should not be provided.

34-3.03(c) Raised-Curb Medians

A median is defined as a raised-curb median if it contains a curb height greater than 2 in (50 mm) within its limits. Usually, a raised-curb median is proposed when the Department needs to manage access to the street and to control left-turn movements. Chapter 48 discusses several advantages and disadvantages of raised-curb medians compared to TWLTL medians. If a raised-curb median is proposed, consider the following in the design of the median:

1. Widths. The minimum raised-curb median width on urban and suburban streets is 18 ft (5.5 m). This width is used only where the majority of intersections along the street will be signalized. If many intersections do not need to be signalized, then the recommended minimum width is 22 ft (7.0 m), assuming no right-of-way restrictions. The 22 ft (7.0 m) median width allows passenger vehicles to comfortably store within median crossovers at unsignalized intersections when making a maneuver in two moves. Where dual left-turn lanes are required, the minimum raised-curb median width is 30 ft (9.5 m) and desirably 36 ft (10.5 m).
2. Cross Slopes. For raised-curb medians, the following cross slopes will apply:
 - a. Median Width Less Than or Equal to 22 ft (7.0 m). Slope the median surface or median pavement towards the through traveled way; see Illustration "A" in Figure 34-3.B. Slope the gutter towards the median to capture median runoff and ice melt and provide a closed drainage system.
 - b. Median Width Greater Than 22 ft (7.0 m). The median surface typically will be sloped toward the centerline of the median; see Illustration "B" in Figure 34-3.B. The gutter will typically be sloped toward the traveled way because median runoff and ice melt are insignificant considerations.
3. Median Island (Paved Surface). For raised-curb medians up to 22 ft (7.0 m) wide, pave the island according to the details in the *IDOT Highway Standards*. A 4 in (100 mm) thickness typically is used. At the noses of islands where vehicles frequently ride over the nose, ramp the median nose and construct it as one solid element. See the *IDOT Highway Standards*.
4. Median Island (Sodded Surface). For raised-curb medians greater than 22 ft (7.0 m), the area between the curbs may be backfilled and sodded. However, where there are numerous signs, median barriers, bridge piers, etc., in the island or where median

crossovers are closely spaced with left-turn lanes, it may be more economical to pave the island to eliminate excessive hand mowing.

5. Drainage. Give consideration to providing subsurface drainage (underdrains) of raised curb medians. Earth or aggregate backfill in the medians may become saturated and bleed water through joints or cracks in the pavement.

34-3.03(d) Depressed Medians

Wherever practical, use a depressed median on rural freeways, expressways, and other designated arterials. Depressed medians have better drainage and snow storage characteristics and, therefore, are preferred on high-speed arterial highways. In addition, they provide the driver with a greater sense of comfort and freedom of operation. Where a depressed median is proposed, the designer should consider the following:

1. Widths. Depressed medians should be as wide as practical to allow for the addition of future travel lanes on the inside while maintaining a sufficient median width. In addition, the median should be sufficiently wide so that a median barrier will not be warranted. Chapters 44 through 48 provide the recommended minimum depressed median widths.
2. Longitudinal Gradeline. The recommended center longitudinal gradeline of a depressed median with an unpaved ditch is 0.5% with 0.3% considered as a minimum. However, on long approach roadways to major river or stream crossings, the design profile gradeline of the roadways may be 0% with the median ditch gradeline designed as a special ditch to provide proper drainage.
3. Drainage. Because water is allowed to flow into a depressed median, the designer needs to consider drainage when determining the appropriate depth of a depressed median. The usual depth is 3 ft (1 m). Chapter 40 of the *BDE Manual* and the *IDOT Drainage Manual* provide additional details on drainage design.

34-3.04 Median Selection

34-3.04(a) General

When selecting a median type, recognition must be given to urban/rural location, access needs, design speeds, availability of right-of-way, safety, capacity, intersection spacing, traffic signals, economics, environmental impacts, public acceptance, and functional classification. Note that higher functional classifications will warrant a greater effort in managing access to a street or highway and in retaining mobility.

Guidelines for median types through large “residential” areas are not provided. These areas typically are avoided in the location of arterial routes and should be treated as special cases. When selecting median types within urban fringe areas, urban outlying business districts, and throughout the entire suburban area (especially within the limits of “closed suburban”), special efforts will be necessary to coordinate the proposed median design with existing and planned

zoning regulations. This will require contacting the responsible zoning boards and/or local officials to coordinate the planning and selection of a median type.

On certain projects, more than one median type may be necessary and/or desirable. The length of a project will be a major influence in this determination. On relatively short highway sections, the number of different median types should be limited to a select few. On longer highway projects, changes of median types should generally be made at the borders of natural cultural subdivisions.

34-3.04(b) Urban Median Types

On streets in downtown areas or central business districts (CBD), abutting building development often prohibits space for off-street parking and entrance driveways for individual businesses. These conditions, plus the extensive use of one-way street systems in the CBD, generally lessen the need for medians and protective left-turn lanes. However, where a median may be required, an 11 ft (3.3 m) or 12 ft (3.6 m) flush median delineated by paint and/or thermoplastic pavement markings is usually appropriate. Where intersections are closely spaced, the median generally will be delineated as an “S” shape to provide overlapping left-turn lanes. Figure 34-3.C provides an example of a typical median design in the CBD and typically widths.

In the urban fringe areas and outlying business districts, off-street parking and entrance driveways usually are quite numerous. Consequently, a raised-curb median generally is not appropriate in these areas because it deters access to abutting businesses and homes. In these areas, a 12 ft (3.6 m) to 13 ft (4.0 m) wide flush TWLTL median or a 16 ft (5.0 m) wide traversable TWLTL median generally is desirable. These median widths provide space for left-turn lanes at intersections and offer protection for the mid-block left-turning vehicles. Where traffic volumes and mid-block left turns are unusually high, the traversable TWLTL median with an M-2.12 (M-5.30) CC&G may be the most desirable design. Figure 34-3.D provides an example of a typical median design in fringe areas and outlying business districts. The design speeds are usually either 30 mph to 40 mph (50 km/h or 60 km/h).

Freeways and expressways in urban areas will generally require a flush median with concrete barrier due to the need to incorporate the necessary cross section within a restricted right-of-way. Desirably, this median width should be 22 ft (7.0 m), which allows for 10 ft (3.0 m) left shoulders and 2 ft (1.0 m) for the concrete barrier. Wider widths may be required; see Chapters 44 and 45. At a minimum, a 20 ft (6.0 m) width with a concrete barrier is considered acceptable under the reconstruction category with only two lanes in each direction.

34-3.04(c) Suburban Median Types

Suburban areas are divided into two subcategories — closed and open. These are discussed in Section 43-2. The appropriate medians for each of these area types are discussed below:

1. Closed Suburban. The following median types will apply:

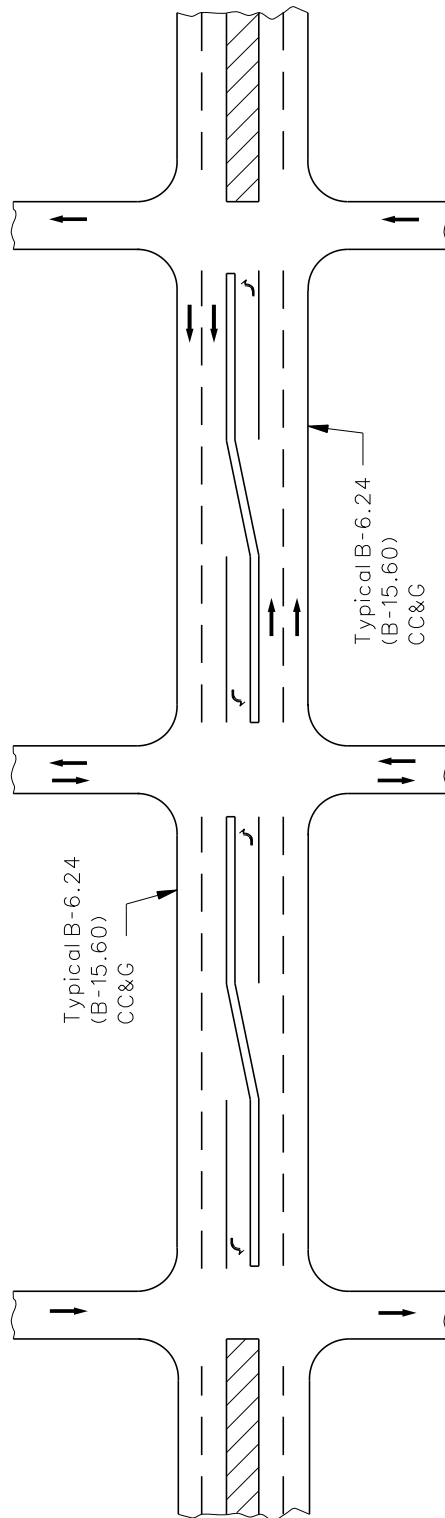

Notes:

- Assumed design speed is 30 mph (50 km/h).
- Overlapping left-turn lanes in median are usually marked with paint or thermoplastic.
- Uniform width: 11 ft or 12 ft (3.3 m or 3.6 m).

TYPICAL MEDIAN DESIGN
(Central Business District)

Figure 34-3.C

* The designer may use M-6 (M-15) curb in these areas to restrict access at the intersection.

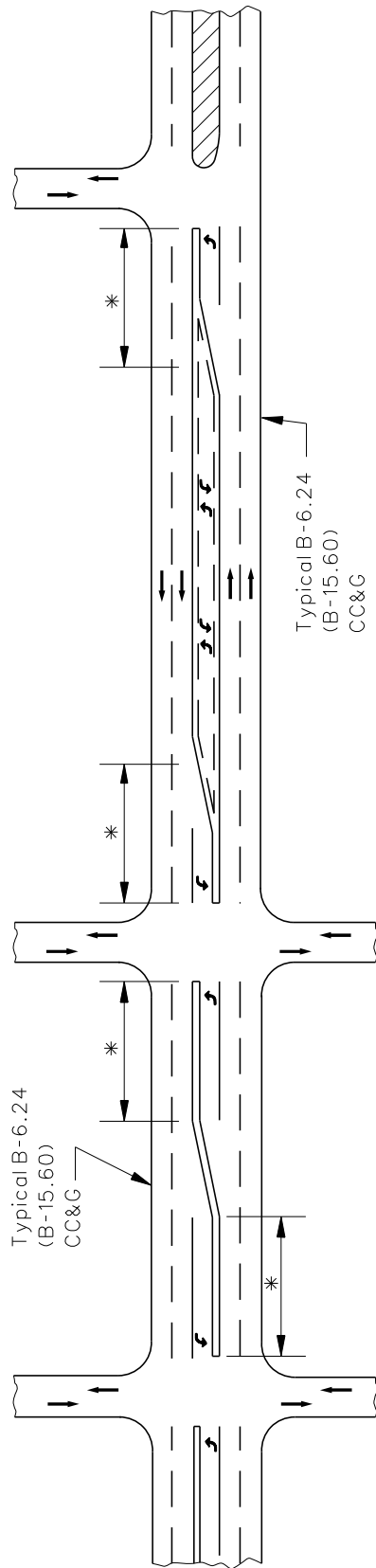

FLUSH TYPE MEDIAN	TRAVERSABLE TYPE MEDIAN
Uniform Width: 12 ft or 13 ft (3.6 m or 4.0 m)	Uniform Width: 16 ft (5.0 m)
Usually marked with paint or thermoplastic.	Median outlined with M-2.12 (M-5.30) CC&G.
Used as two-way, left-turn lane in mid-block locations.	Used as two-way, left-turn lane in mid-block locations.

TYPICAL MEDIAN DESIGNS
(Fringe and Outlying Business District)

Figure 34-3.D

- a. TWLTL Medians. This median type can consist of either a flush TWLTL median or a traversable TWLTL median and is typically used with curb and gutter along the outside edges of the traveled way. These median types are applicable where the existing predominant abutting development includes numerous and closely spaced commercial entrance driveways. It is particularly appropriate where there is strip development and no appreciable street network. Design speeds should not exceed 45 mph (70 km/h). Preferably, the maximum number of through lanes should not be greater than two in each direction. The traversable TWLTL median is occasionally used in metropolitan areas where traffic volumes and mid-block left turns are unusually high.
- b. Raised-Curb Medians. This median type is generally applicable where a design speed of 40 mph or 45 mph (60 km/h or 70 km/h) is desired and a street network exists to permit access to the predominant abutting development. On six-lane urban streets, the raised-curb median is the most appropriate design. Normally, right-of-way should be available to provide for either a 16 ft (5.0 m), 18 ft (5.5 m), or 22 ft (7.0 m) wide curbed median. These widths provide space for the initial and future installation of left-turn lanes at public street intersections and high-traffic generator locations. Access to any strip development or open-space segments usually can be provided by properly spaced median openings and service drives. This median type should be coordinated with the local officials because mid-block left turns are prohibited.

Where managing access to the street is practical and desirable, consider using the 22 ft (7.0 m) wide median as the first design option. Where right-of-way is more restricted, or if most intersections will be signalized in the future, consider using the 18 ft (5.5 m) wide median. The use of the 16 ft (5.0 m) wide raised-curb median only should be considered in areas where right-of-way is highly restricted and the use of a wider curbed median is not feasible. If dual left-turn lanes are required, the median width at intersections should be a minimum of 30 ft (9.5 m) wide and desirably 36 ft (10.5 m) wide.

2. Open Suburban. The following median types will apply:
 - a. TWLTL Medians. Selection of this median type is based on the same criteria as discussed in Item 1 above for a closed suburban area.
 - b. Raised-Curb Medians. This median type is applicable where a maximum 45 mph (70 km/h) design speed is desired and where managing access to the street is practical and desirable. Availability of right-of-way typically favors a median width narrower than 44 ft (13.2 m). For open suburban areas, raised-curb median widths of 18 ft (5.5 m) or 22 ft (7.0 m) generally are considered the most feasible widths. The 22 ft (7.0 m) width allows for U-turn movements and the storage of passenger vehicles in the median crossover at unsignalized intersections. Consider using the 18 ft (5.5 m) wide median where right-of-way is restricted.

In conjunction with these median widths, provide spacing of median openings at approximately 500 ft to 600 ft (150 m to 180 m) apart. Construct all necessary median openings initially allowing for slight adjustment of the spacing requirements to fit existing intersections, property limits, drainage ways, and terrain. The location of all possible future median openings should be shown in the approved Phase I report. Provide left-turn lanes at all median crossovers and at future median openings as they are constructed.

Existing and future developments abutting the highway should plan their traffic circulation according to the initial median openings or the proposed median openings as shown in the Phase I report. Accordingly, it should be emphasized in discussions with municipalities and developers, that private service drives and/or coordination of other traffic circulation facilities with adjacent property owners will be a necessary part of the land-use planning.

- c. Depressed Medians. This median design in suburban locations is applicable for non-access controlled highways where a 50 mph (80 km/h) design and posted speed are preferred and where right-of-way reasonably can be acquired for inclusion of necessary safety features. The following will apply:
- Typical median widths are 44 ft (13.2 m) to 50 ft (15 m). These widths provide for 6 ft (1.8 m) to 8 ft (2.4 m) wide median shoulders, 1V:6H or 1V:5H median slopes, and a 2 ft (500 mm) wide median ditch.
 - U-turns are afforded better protection with these median widths and can be permitted indefinitely even with left-turn lanes.
 - As a minimum, access to abutting properties with this type median would be accommodated in the same manner as described above for raised-curb medians. Where practical, consider more restrictive access to the highway in a manner similar to expressway designs.

34-3.04(d) Rural Median Types

In rural areas, medians are typically only provided on freeways, expressways, and other designated high-speed arterials. Also, median islands are provided at rural intersections for the inclusion of left-turn lanes and on crossroads through interchanges. In general, right-of-way is not a problem. Typical median types in rural areas include depressed medians, flush medians, and short sections of raised-curb medians. The primary function of a median in rural areas is to increase operational safety of the highway by neutralizing the interference of opposing traffic. Selection of rural median types is based on the following:

1. Depressed Medians. This median design is applicable for both access and non-access controlled highways and where right-of-way can be reasonably acquired. Depressed medians are mainly used on the following:

- a. Freeways. Depressed median widths for new freeways are either 56 ft (17 m) (four lanes) or 60 ft (18 m) (six lanes). These median widths provide for 8 ft (2.4 m) or 10 ft (3.0 m) wide left shoulders, 1V:6H median slopes, and a 4 ft (1.2 m) wide ditch. See Chapter 44 for typical sections of four-lane and six-lane freeways.
- b. Expressways and Four-Lane Minor Arterials. For new construction and reconstruction projects, the median width for these type highways is 50 ft (15 m). This median width will also accommodate 1V:6H median slopes and a 2 ft (600 mm) wide ditch because of the narrower median shoulders. See Chapter 45 for typical sections.

On expressway-type highways, median widths wider than 50 ft (15.0 m) generally are not recommended, except at isolated intersection locations where a large number of tractor-trailer movements exist and where traffic signals will not be required. In this situation, it is recommended that the designer use an 60 ft (18.0 m) to 65 ft (19 m) wide median. These wider medians through the intersection will allow for median storage of the tractor-trailer unit.

Where expressways are developed through reconstruction of existing two-lane highways, the addition of near-parallel lanes may cause extra-wide median widths at existing horizontal curves. Where the added roadway is on the outside of an existing curve, the alignment transition to a uniform median width generally should be constructed on one end of the proposed horizontal curve only (i.e., either upstream or downstream). Where the added roadway for the proposed expressway is located on the inside of an existing curve (allowed to remain in place), the proposed horizontal curve is designed to fit into back and forward tangents. This design then provides for a variable width median through the two adjacent horizontal curves. See Chapter 45 for median widths allowed to remain in place.

2. Flush Medians. Flush medians consist of two double yellow lines marked at the edge of the traveled way with transverse striping in the median area. This median type is mainly used at rural intersections where left-turn lanes are needed and as an alternative to raised-curb median islands at isolated intersections.
3. Raised-Curb Medians. On high speed (≥ 50 mph (80 km/h)) rural multilane highways, do not delineate medians with continuous curbing because it may constitute a safety hazard. However, median curbing may be used at isolated intersections (see Chapter 36) and through interchange crossroad locations where more positive control measures are needed to promote safer traffic operations or where required for proper drainage. In these situations, use an M-2 (M-10) curb along the crossroad median; see Figure 34-2.A.

34-4 ROADSIDE ELEMENTS

34-4.01 General

Earth slopes are required to provide roadside and median ditches adjacent to highway facilities and to provide a stable transition from the highway profile to adjacent terrain features. With maintenance operations, economy may be attained through the use of mechanized equipment which operates best on relatively flat earth slopes. Flat slopes also facilitate turf establishment and are often required for soil stability. In addition to aesthetic enhancement, flat and well-rounded side slopes, combined with proper roadway elevations above natural ground lines, minimize snow drifting problems. With proper elevations, cross winds sweep the snow from the roadway surface, thus facilitating snow removal operations.

Using broad flat slopes on roadside ditches, which are totally visible to the driver, lessens the feeling of restriction and add considerably to a driver's willingness to use the shoulder and earth slope area in emergencies. The use of flat side slopes for roadside ditches reduces both the depth and velocity of water, and thereby minimizes damage from erosion. See Chapter 38 for guidance on earth slopes and clear zones.

For urban facilities other than freeways and expressways, side slopes generally will be determined on a case-by-case basis considering the roadside development and right-of-way restrictions. For some urban projects, relatively steep side slopes and/or retaining walls may be required.

34-4.02 Fill Sections

Front slopes in fill sections are the slopes extending outward and downward from the hinge point to intersect the ditch bottom or natural ground line. The slope criteria depends upon the fill height, urban/rural location, project scope of work, and the presence of curbs. Figures 34-4.A and 34-4.B present the fill slope criteria. The designer should also consider the following:

1. Maximum Slope. As indicated in Figures 34-4.A and 34-4.B, the maximum front slope should be 1V:3H. A 1V:3H slope is a practical maximum when considering maintenance operations (e.g., mowing), erosion control, and roadside safety. Slopes steeper than 1V:3H should be used where fill heights are greater than 30 ft (9 m). Slopes steeper than 1V:3H will normally require a roadside barrier; see Figure 38-6.J for the location of the barrier where curbs are present.
2. Shelf. For curbed sections, a 3 ft to 10 ft (900 mm to 3.0 m) shelf is provided beyond the curb. If sidewalks are present or anticipated, the shelf width should be 10 ft (3.0 m) and sloped away from the roadway at a rate of 2%. If no sidewalks are present or anticipated, slope the shelf away from the roadway at 5%.

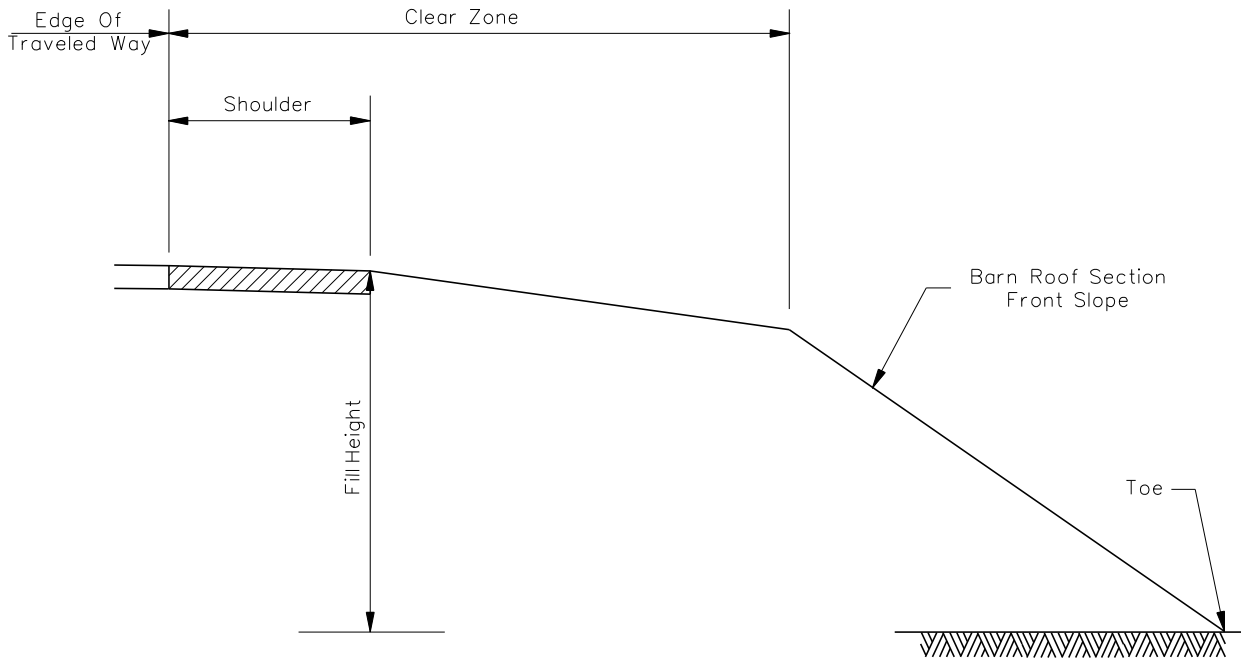

Project Scope of Work	Fill Height	Front Slopes (V:H)
New Construction and Reconstruction	0 ft – 30 ft (0-9 m)	1:6 to clear zone edge 1:3 maximum to toe
	>30 ft (>9 m)	1:2 uniform slope with a roadside barrier
Existing to Remain (Reconstruction)	0 ft – 30 ft (0-9 m)	1:4 to clear zone edge 1:3 maximum to toe
	>30 ft (>9 m)	1:2 uniform slope with a roadside barrier

**TYPICAL FILL SECTIONS
(Highways Without Curbs)**

Figure 34-4.A

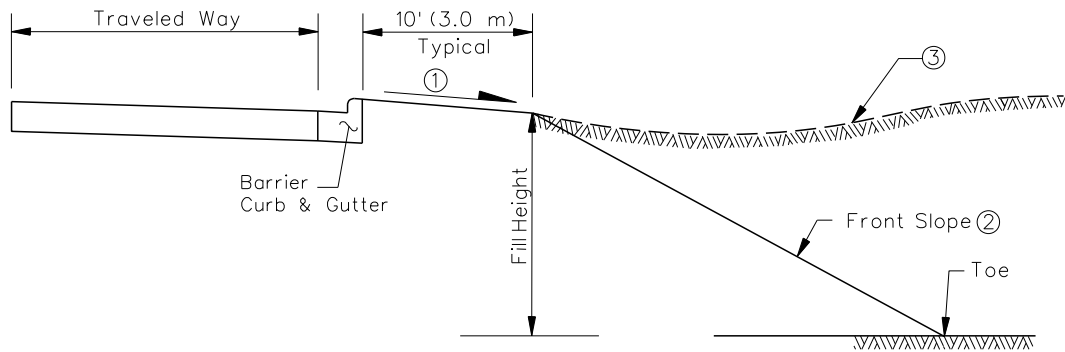

Notes:

- ① See Item 2 in Section 34-4.02 for slope rates.
- ② Desirable - 1V:4H; see Chapter 38.
- ③ For urban and suburban reconstruction projects, see Item 4 in Section 34-4.02.

(A) DESIGN SPEED \leq 45 mph (70 km/h)

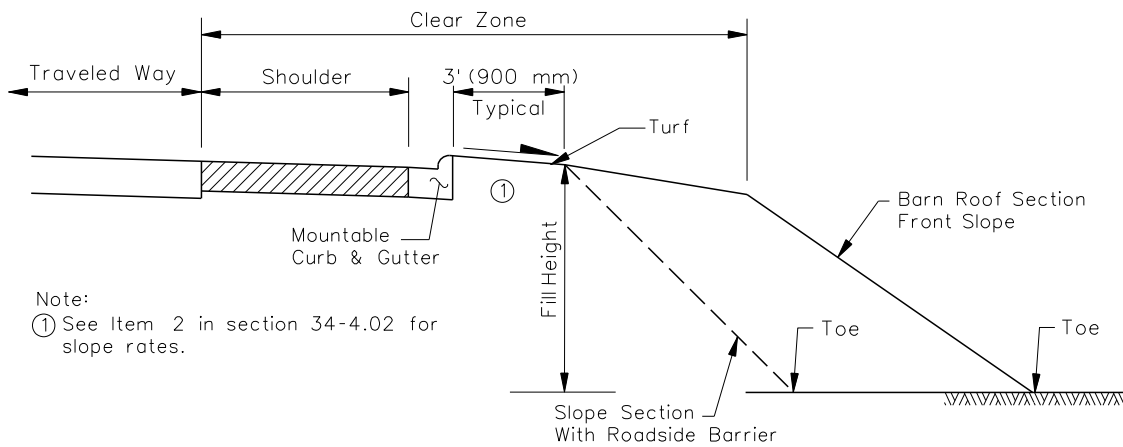

Note:

- ① See Item 2 in section 34-4.02 for slope rates.

(B) DESIGN SPEED \geq 50 mph (80 km/h)

Project Scope of Work	Fill Height	Front Slopes (V:H)
New Construction and Reconstruction	0 ft – 30 ft (0-9 m)	1:6 to clear zone edge 1:3 maximum to toe
	> 30 ft (>9 m)	1:2 uniform slope with a roadside barrier
Existing to Remain (Reconstruction)	0 ft – 30 ft (0-9 m)	1:4 to clear zone edge 1:3 maximum to toe
	> 30 ft (>9 m)	1:2 uniform slope with a roadside barrier

Note: For clear zones in curbed sections, see Section 38-3.

**TYPICAL FILL SECTIONS
(Curbed Facilities)**

Figure 34-4.B

3. Benching. Where the height of a fill exceeds 30 ft (9 m), consider benching of the slope to minimize erosion problems. Approximately halfway down the slope, provide a bench with a V-type ditch. On short sections, the bench can be graded to drain to one side. For longer sections, grade the bench to drain from both directions. For more guidance on benching designs, the designer should contact the district geotechnical engineer.
4. Reconstruction Projects. For some reconstruction projects in urban or suburban locations, the existing pavement may be slightly above the surrounding topography. If this occurs, provide a drainage swale behind the curb and gutter as illustrated in Figure 34-4.B.
5. Other Considerations. Although Figures 34-4.A and 34-4.B provide specific criteria for front slopes, also consider right-of-way restrictions, utility considerations, and roadside development when determining the appropriate front slope for the site conditions. If practical, consider using flatter front slopes than indicated.

34-4.03 Ditch Sections

34-4.03(a) Typical Slope Rates

On facilities without curb and gutter, roadside ditches are provided adjacent to embankment locations and in cut sections to control drainage. Figure 34-4.C presents IDOT criteria for embankment locations and cut sections. As illustrated in Figure 34-4.C, the ditch section includes the front slope, ditch width and back slope for the type of highway. Where the cut height exceeds 10 ft (3 m) from the bottom of the ditch to the existing ground line, the designer may consider using a 1V:2H back slope beyond the clear zone to reduce excavation costs.

Where the height of a cut exceeds 30 ft (9 m), consider benching the back slope to minimize erosion problems. Approximately halfway down the slope, provide a bench with a V-type ditch. On short sections, the bench can be graded to drain to one side. For longer sections, grade the bench to drain from both directions. For additional guidance on benching designs, the designer should contact the district geotechnical engineer.

34-4.03(b) Material and Soils Conditions

The designer must ensure that permanent erosion control is considered in the design of ditches in cut slopes. The designer should contact the district landscape architect and the district geotechnical engineer, who will review the existing soil conditions to determine if additional measures may be required to control erosion (e.g., additional topsoil, special plantings, paving). It will be the designer's responsibility to consider their recommendations for incorporation into the plans. As a general guide, longitudinal ditch slopes less than 1% can be seeded, slopes of 1% to 3% usually will require sodding or seeding with an erosion control blanket, and slopes greater than 3% will require riprap or other protective lining. Very flat longitudinal ditch slope

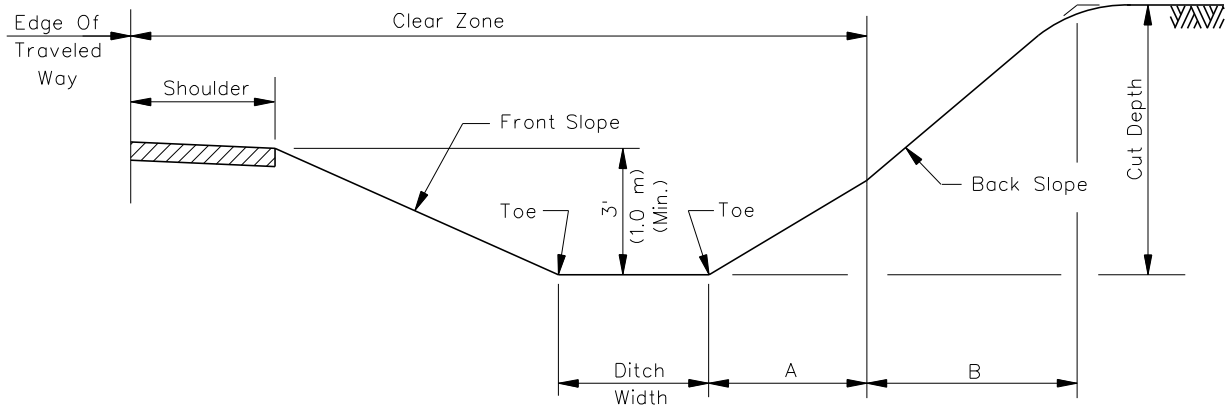

Project Scope of Work	Front Slope (V:H)	Minimum Ditch Width	Back Slopes (V:H)	
			A	B
New Construction or Reconstruction	1:6	4 ft (1.2 m) ⁽¹⁾	1:3	(2)
Existing to Remain (Reconstruction)	1:4	2 ft (500 mm) ⁽¹⁾	1:3	(2)

Notes:

- (1) A wider ditch may be used where detention storage of storm water is an important consideration.
- (2) Where the height of cut exceeds 10 ft (3 m), consider using a 1V:2H back slope beyond the clear zone. See Section 38-3 for discussion on clear zones.

TYPICAL DITCH SECTIONS

Figure 34-4.C

(i.e., < 0.4%) may require a paved ditch so as to maintain the flowline over time. For more information on the design of ditch linings, the designer should review Chapter 40 in the *BDE Manual* and the *IDOT Drainage Manual*.

34-4.03(c) Hydraulic Design

Roadside and median ditches are to be designed according to the criteria presented in Chapter 40 and the *IDOT Drainage Manual*. The use of this criteria will ensure the proper drainage of the pavement subgrade and the adequate conveyance of surface flow without creating erosion of ditch sections.

34-4.04 Cut Sections With Curbs

On facilities with curbs, a shelf is provided with a back slope beyond the shelf. The shelf is usually sloped towards the roadway to eliminate the need for a separate drainage system behind the curb. Where sidewalks are present or anticipated in the future, provide a shelf width of 10 ft (3.0 m) with a cross slope of 2%. Where sidewalks are not present or anticipated in the future, the shelf cross slope should be 5% to provide for adequate drainage. This criteria is illustrated in Figure 34-4.D.

Where the height of a cut exceeds 30 ft (9 m), consider benching the back slope to minimize erosion problems. Approximately halfway down the slope, provide a bench with a V-type ditch. On short sections, the bench can be graded to drain to one side. For longer sections, grade the bench to drain from both directions. For additional guidance on benching designs, the designer should contact the district geotechnical engineer.

34-4.05 Rock Cuts (Back Slopes)

In rock cuts, the back slope generally is 1V:0.25H but could vary depending on the type of rock and field conditions; see Figure 34-4.E. For large cuts, benching of the back slope may be required. For guidance on benching designs in rock cuts, the designer should contact the district geotechnical engineer.

Conduct a cost-effective study to determine if a rock cut should encroach into the clear zone area or be located outside of the clear zone. If the rock face is located within the clear zone, provide a smooth rock cut or shield it with a roadside barrier. If the rock face and ditch to capture falling rock is outside of the clear zone, a roadside barrier typically will not be warranted.

In addition, conduct a hydraulic analysis to evaluate the need to control cascading water from the top of the cut and to determine the conveyance needs or roadside drainage at the toe of the cut.

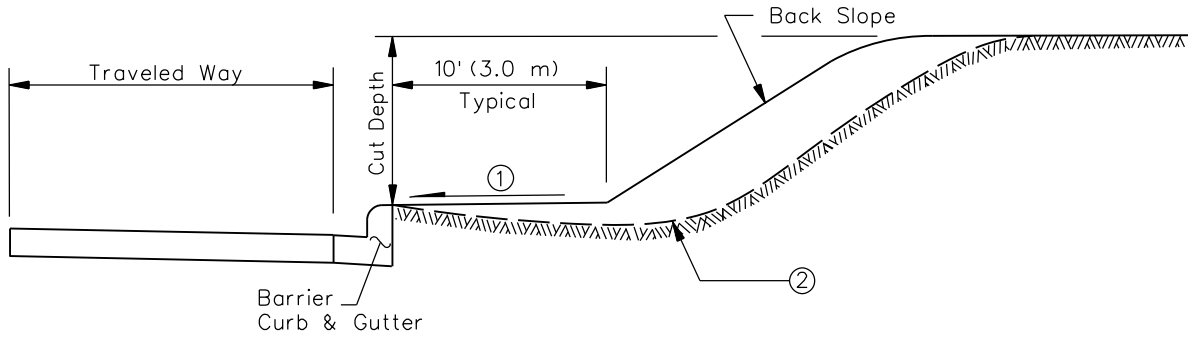

Notes:

- ① 2% If sidewalks are present or anticipated.
5% If sidewalks are not present or anticipated.
- ② Drainage swale may be needed to meet field conditions.

Facility	Back Slopes (V:H)
Urban Arterials	1:3
Urban Marked Route Collectors	1:2

(A) DESIGN SPEED \leq 45 mph (70 km/h)

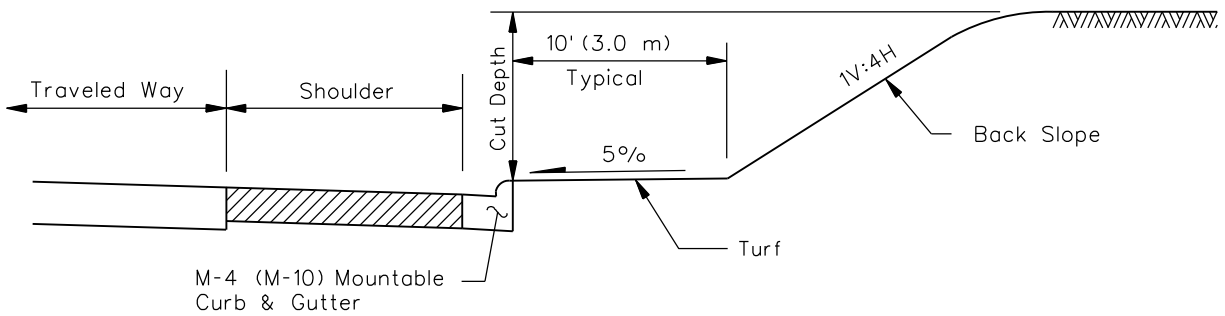

(B) DESIGN SPEED \geq 50 mph (80 km/h)
(RESTRICTED RIGHT-OF-WAY)

Note: See Section 38-3 for clear zone discussion.

**TYPICAL CUT SECTIONS
(Curbed Facilities)**

Figure 34-4.D

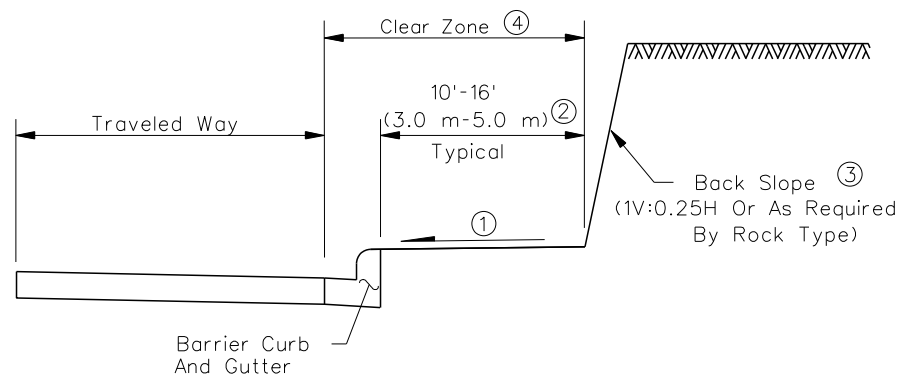
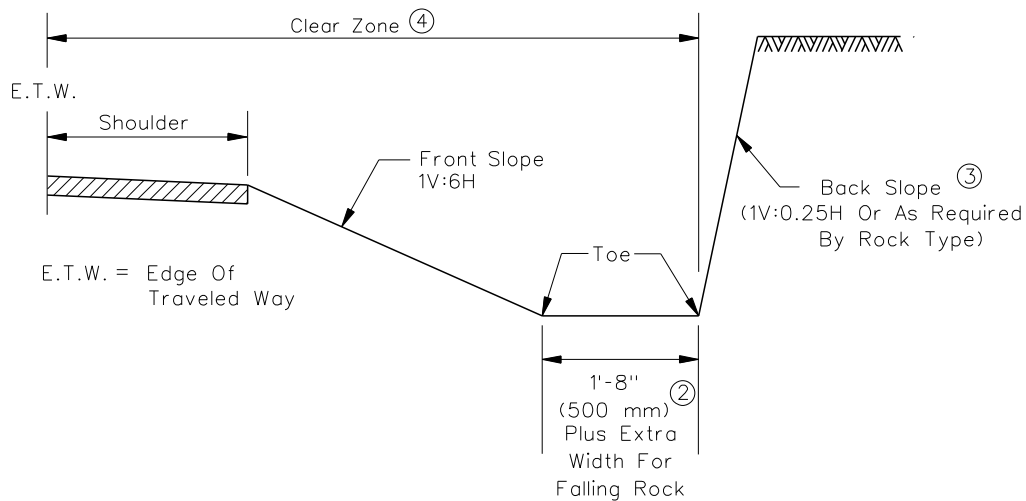
(A) DESIGN SPEED \leq 45 mph (70 km/h)(B) DESIGN SPEED \geq 50 mph (80 km/h)**Notes:**

- ① Use 2% if sidewalks are presented or anticipated. Use 5% if sidewalks are not present or anticipated.
- ② Discuss with the district geotechnical engineer to determine extra width needed for falling rock.
- ③ Back slopes in rock may require benching. Contact the district geotechnical engineer.
- ④ See Section 38-3 for clear zone discussion.

TYPICAL ROCK CUT SECTIONS**Figure 34-4.E**

34-4.06 Roadside Safety

To safely accommodate a run-off-the-road vehicle, all slopes should be as flat as practical. Section 38-3 presents specific criteria to determine desirable front slope, ditch width, and back slope combinations. All hazards within the clear zone should be removed, relocated, made breakaway, or shielded.

34-4.07 Transverse Slopes

Common obstacles along roadsides are embankment (transverse) slopes created by median crossovers, driveways, or intersecting side roads. The criteria for designing transverse slopes are discussed in Section 38-4.

34-4.08 Geotechnical Features

During the Phase I development stage, the designer must ensure that the topography and geology of the selected alignment and profile are compatible with the proposed fill and cut slope sections. The use of earthwork computer programs will help to determine cross section limits. In addition, on new construction or reconstruction projects, the Phase I Geotechnical Report and any additional data must be analyzed during the preparation of the construction plans. This will help to ensure the stability of selected cut and fill slopes which are 1V:3H or steeper.

Major or unusual geotechnical features within the project limits will require special consideration. These features should be reviewed with the district geotechnical engineer. Usually, a meeting to discuss the geotechnical features will be warranted. The designer should discuss geotechnical features with the district geotechnical engineer, when the project includes the following:

1. Earthwork. Soil or rock cuts or fills where:
 - the maximum height of cut or fill exceeds 30 ft (9 m), or
 - the cuts or fills are located in topography and/or geologic areas with known stability problems.
2. Soil and Rock Instability Corrections. Cut, fill, or natural slopes which are presently or potentially unstable.
3. Retaining Walls. Where the maximum height at any point along the length of the retaining wall exceeds 10 ft (3 m), the Bureau of Bridges and Structures will be responsible for the retaining wall design and review. Geotechnical aspects may include bearing capacity, settlement, overturning, and sliding. When selecting the wall type, note that precast concrete block walls are not appropriate:

- in areas which will be exposed to salt or other de-icing chemicals;
 - in wet areas which will keep them in a saturated condition, therefore allowing detrimental freezing to occur (e.g., a wall next to a pond, lake, or stream);
 - for structurally critical applications (e.g., a wall to retain a road, support a bridge cone, support an abutment/pier);
 - for tiered wall systems; and
 - for walls higher than 5 ft (1.5 m), as measured from the top of the block elevation to the finished grade line at the wall face.
4. Difficult or Unusual Geotechnical Problems. These conditions may include embankment construction on weak and compressible foundation material (difficult) or fills constructed using degradable shales (unusual).
5. New or Complex Designs. This may include geotextile soil reinforcement, permanent ground anchors, wick drains, stone columns, etc.
6. Unusual Design Methods. This may include experimental retaining wall systems or pile foundations where dense soils exist.

34-4.09 Aesthetics

The designer should explore various options to improve the visual impact a roadway will have on the landscape. Varying the cross section elements will typically improve the aesthetics of the roadway. This may include:

- increasing or decreasing the side slopes to reduce the magnitude of exposed cut and fill slopes,
- reducing ditch widths or depths to reduce the amount of cut,
- using slope rounding to blend cuts and fills into the natural ground,
- warping side slopes to match the natural landscape,
- retaining existing vegetation,
- using a raised-curb or depressed median with plantings, and
- providing structures which match the natural landscape.

Section 33-6.03 provides additional guidance for improving highway aesthetics relative to its surroundings. Address aesthetic issues with the Stakeholders during the Context Sensitive Solutions (CSS) process.

34-5 RIGHT-OF-WAY

34-5.01 General

The purpose of acquiring highway rights-of-way is to provide sufficient room to construct the facility, to enable the safe operation of vehicles on the facility, and to permit the safe and efficient maintenance of the facility.

The Bureau of Program Development in Districts 2 through 9 and the Bureau of Programming in District 1 are responsible for plotting highway cross sections during Phase I studies. These cross sections aid in establishing the right-of-way width required for the construction and future maintenance of the highway. However, the exact final location of the right-of-way line will be the responsibility of the District Chief of Plats and Plans after all environmental commitments, construction, safety, and maintenance requirements have been met. The guidance used by the District Chief of Plats and Plans is contained in *IDOT Land Acquisition Policies and Procedures Manual*.

34-5.02 Definitions

The following definitions apply:

7. Permanent Right-of-Way. Right-of-way acquired for permanent ownership by the State for activities which are the responsibility of the State for an indefinite period of time. The State obtains the title to the property. Permanent right-of-way is typically acquired for roadways, roadsides, etc.
8. Temporary Construction Easement. Easements acquired for the legal right of usage by the State to serve a specific purpose for a limited period of time (e.g., construction, maintenance and protection of traffic during construction). Once the activity is completed, the State yields its legal right of usage.
9. Permanent Easements. Easements acquired with the perpetual right to construct and maintain a public highway and incidental facilities over and across the surface of lands. Types of permanent easements include:
 - highway easements,
 - utility easements,
 - storm sewer easements, and
 - areas of soil or ground water contamination.
10. Channel Easements. Easements acquired specifically for stream channel construction and maintenance, which provides the State with a permanent right of ingress and egress. The property owner relinquishes the right to modify the channel dimensions (e.g., slopes).

34-5.03 Establishment of Right-of-Way Lines

Proposed right-of-way lines will be dimensioned from a centerline or survey line. Centerlines may be the centerline of pavement to remain in place, proposed centerline of pavement, centerline of median, or centerline of platted streets. Survey lines may be a survey line of the proposed improvement or relocated survey line. Do not dimension the right-of-way line from a centerline of pavement in place, existing right-of-way line, or any other line that will be removed. Dimensions must be from a line that can be located in the field (e.g., monuments, physical objects, ties).

34-5.04 Right-of-Way Width

Width of the proposed right-of-way or break points in rural areas should be based on multiples of 5 ft (2 m) (e.g., 65 ft, 70 ft, 75 ft). Avoid widths of right-of-way or break points that are a decimal of a foot (meter) unless the proposed right-of-way line is along the property line. However, there may be cases where the proposed right-of-way or break points are rounded off to the nearest foot (300 mm) (e.g., existing development, near or at the back edge of the sidewalk). Right-of-way lines parallel or concentric with the existing centerline or survey line are the most desirable. On curves, it also may be advantageous to use a series of straight lines.

In general, for new facilities, the minimum right-of-way width will be the sum of the traveled way(s), outside shoulders, median width (if applicable), necessary width for fill and cut slopes, plus a maintenance border area beyond the construction limits. The total width will vary according to the functional classification and urban/rural environment.

In general, minimal additional right-of-way will be required for 3R projects. However, ditch cleaning and slope flattening may be desirable on these projects. Consequently, strips of minimum width of right-of-way or easements may be required.

Adequate right-of-way must also be attained around side road radius returns to accommodate the shoulder and ditch/drainage transition from the mainline to the side road. Culverts also require special attention particularly on extensions. Right-of-way may be required to match existing channels.

In addition to the border area beyond the construction limits, allowance may be necessary for the provision of frontage roads, special drainage facilities, roadside clear zones, and future expansion of the highway. These border areas are required for maintenance operations, the retention of natural growth for scenic and ecological purposes, erosion control and, in some cases, for accommodating public utilities; see Section 34-6. Border areas also serve as a buffer between the limits of construction and abutting private development.

34-5.05 Other Considerations

In addition to the minimum right-of-way widths, the designer should consider the following:

6. Design of Right-of-Way Breaks. Desirably, the right-of-way limits should be uniform and the number of breaks minimized. This will limit the number of right-of-way markers or corner fence posts. In addition, the designer should consider the following:
 - a. Break Points. Identify each “break point” in the right-of-way line by a station and offset distance from the centerline or the survey line of construction.
 - b. Changes. Avoid abrupt changes in the right-of-way lines. Where changes are required, the rate of change should be as flat as practical.
 - c. Breaks on Property Lines. A change in the distance from the centerline to the right-of-way line should not occur on a property line if there is a taking from two adjacent properties. Right-of-way markers set on apparent property lines in the past are now considered by their owners as located on the property lines, which may or may not be correct.
 - d. Non-Stakable Breaks. Avoid right-of-way breaks where the break points cannot be staked. For example, avoid a right-of-way break point in a stream or in a driveway. Also, right-of-way breaks should be at least 20 ft (6 m) from the edge of any body of water (e.g., lakes, streams).
 - e. Small Parcels. Additional right-of-way break points and short distances between breaks may be considered only where it will eliminate a taking (parcel) or will avoid leaving a small uneconomical remnant. In rural areas, small irregular and triangular-shaped remainders less than 50 ft (15 m) in width will be included as part of the right-of-way. To avoid relocating a building in urban areas, the right-of-way line may need to be adjusted.
7. Acquiring Fee to Dedicated Right-of-Way. Obtain the fee interest in right-of-way. When the owner has a fee interest to dedicated right-of-way which is adjacent to the property, the fee interest may be acquired for that portion of the right-of-way which lies between the existing right-of-way line and the property line. This would be in addition to any new right-of-way required. This procedure will eliminate the owner from having to pay taxes on the dedicated right-of-way and will make it easier for utility companies to obtain permits.
8. Utility Adjustments. Problems may occur with utility adjustments where the right-of-way lines are irregular and/or are placed too close to the outer limits of construction. For example, where a pole line is relocated on State right-of-way, the utility company may be faced with the following problems:
 - numerous guy wires,
 - poles or guy wires on private property that require easements and which may cause delays, and/or

- requesting cross sections from the State for the utility company to identify where it may or may not place power and/or communication poles.

Similar problems are encountered with relocated water and gas mains. Although these matters often do not cause direct and tangible cost to the Department, they may create unnecessary expense to the utility and indirectly may create delays to construction and increase user delays.

9. End Right-of-Way Taking (Terminal Parcel). Where a construction project ends within the limits of a particular property, it is desirable to continue the right-of-way across the property if additional right-of-way will be required for a future project. If the proposed project ends within the property, taper the proposed right-of-way line into the existing right-of-way line.
10. Variable Median. For variable width medians, describe the right-of-way from one survey line or centerline, wherever practical. For wide medians (200 ft (60 m) or more), it may be necessary to describe the right-of-way from two survey lines or centerlines.
11. Sidewalks. If a sidewalk will be constructed on a project, locate the right-of-way line a minimum of 1 ft (300 mm) from the back edge of the sidewalk, if practical. Grading for sidewalk construction, which lies outside of the existing or proposed right-of-way, Requires a temporary easement.
12. Intersection Sight Distance (Corner Cuts). Acquire adequate right-of-way to provide the applicable intersection sight distance as described in Chapters 36 and 49.
13. Fee Taking Versus Temporary Easement. Where it is necessary to work outside the existing right-of-way lines for grading of roadside ditches, channel changes, slope rounding, construction of temporary access roads at bridges, and/or other locations, the Department should acquire additional working area in fee interest in lieu of a temporary easement on construction projects. Additional width of right-of-way at bridges will allow for easier access for bridge maintenance and for work on channels (e.g., realignment, placement of riprap, jetties).

34-6 UTILITIES

34-6.01 Definition

A “utility” is defined as a privately, publicly, or cooperatively owned line, facility, or system for producing, transmitting, or distributing communications, cable television, power, electricity, light, heat, gas, oil, crude products, water, steam, waste, storm water not connected with highway drainage, or any other similar commodity. This includes any fire or police signal system or street lighting system, which directly or indirectly serves the public. The term “utility” will also apply to a utility company inclusive of any wholly owned or controlled subsidiary. The term “utility” includes those facilities used solely by the utility which are a part of its operating plant.

34-6.02 Location

In general, it will be the responsibility of the planner and designer to locate, identify and, to the maximum extent practical, avoid disturbance of all existing utilities and to determine, initially, the appropriate utility locations on new construction and reconstruction projects. The planner and/or designer should review Chapter 6 of the *BDE Manual* and the current edition of the *IDOT Accommodation of Utilities on Right-of-Way of the Illinois Highway System* for the latest utility accommodation criteria.

34-6.03 Design Considerations

The overall Department objective is to ensure completion of the required adjustment for all conflicting utility facilities in a mutually satisfactory manner in advance of the roadway construction. The district utility coordinator is responsible for working with the utility companies to develop the relocation design details for utility relocations or adjustments. This criteria is presented in the *IDOT Accommodation of Utilities on Right-of-Way of the Illinois State Highway System*. The designer should ensure that the proposed design is consistent with the proposed highway improvement.

14. Utility Locations. Utility installations should be located as follows:

- Locate longitudinal utilities parallel and as near as practical to the right-of-way line but not more than 8 ft (2.4 m) from the right-of-way line.
- Locate ground-mounted appurtenances for underground facilities within 1 ft (300 mm) or as near as practical to the right-of-way line.
- No new above-ground longitudinal utilities, including any above-ground appurtenances for underground installations, will be placed within the clear zone.
- No new longitudinal utility installations will be permitted under the paved portion of streets and highways under State jurisdiction.

- Utilities will not be permitted to cross under State highways in cattle passes, culverts, or other drainage facilities.
 - New manholes will not be permitted in the traveled way or shoulders of State highways. Existing manholes may remain in place.
 - Utility crossings should be approximately 90° to the highway centerline as practical.
 - No utility appurtenances (e.g., pumping stations, transformers) will be allowed within interchange right-of-way.
 - Special restrictions may be placed on utility companies where visual quality is an important consideration. See *IDOT Accommodation of Utilities on Right-of-Way of the Illinois Highway System* for more information.
15. Cover. The following cover criteria, below the pavement surface, will be required for underground installations:
- a. Power. These installations will require a minimum cover of 30 in (750 mm).
 - b. Communication. Where these installation are installed by the plowed method, the minimum cover will be 2 ft (600 mm).
 - c. Gas Pipelines. Gas installations must have a minimum cover of 30 in (750 mm) at all locations within the highway right-of-way.
 - d. Water Lines. To prevent freezing, place water lines below the frost line.
 - e. Sewers and Drain Lines. Storm sewers, sanitary sewers, and drain lines must have a minimum clearance of 30 in (750 mm) to the top of pipe to prevent freezing.
16. Aerial. The following will apply to power lines and/or communication lines:
- a. Guy Wires and Brace Posts. These devices will not be allowed on the State right-of-way.
 - b. Overhead Clearances. For overhead power and communication lines crossing fully access-controlled facilities, the minimum vertical clearance is 20 ft (6.1 m) and for other facility types 18 ft (5.5 m).
 - c. Location. In general, aerial utility poles should be located as close to the right-of-way line as practical. However, for urban areas the following will apply:
 - Curbed. For curbed sections, the minimum placement distance of poles behind the face of the curb is 18 in (500 mm) to the closest face of the pole.

- Shoulder with Curb and Gutter at Shoulder Edge. The minimum pole placement is 4 ft (1.2 m) beyond the outside of the shoulder to the closest face of the pole. In addition, the clear zone distance must be checked.
17. Light Standards. Place light standards and power poles in accordance with the criteria presented in Chapter 56.
 18. Detours. Awareness of potential utility conflicts is extremely important when constructing detours near the right-of-way line or on temporary right-of-way.

34-7 REFERENCES

19. *A Policy on Geometric Design of Highways and Streets*, AASHTO, 2004.
20. NCHRP Report 375, *Median Intersection Design*, 1995.
21. *Highway Standards*, IDOT, current edition.
22. *Highway Capacity Manual 2010*, Transportation Research Board, 2010.
23. *IDOT Drainage Manual*, Bureau of Bridges and Structures, IDOT.
24. *IDOT Policy on Permits for Access Driveways to State Highways*, IDOT, 1990.
25. *Manual on Uniform Traffic Control Devices*, 2003 Edition, FHWA, ATSSA, AASHTO, and ITE, 2003.
26. *Roadside Design Guide*, AASHTO, 2006.
27. *Land Acquisition Policies and Procedures Manual*, Bureau of Land Acquisition, IDOT.
28. *Accommodation of Utilities on Right-of-Way of the Illinois State Highway System*, IDOT, 1992.
29. *Flexibility in Highway Design*, FHWA and AASHTO, 1997.
30. *Determining Economic Impacts on Adjacent Businesses Due to Restricting Left Turns*, NCHRP 25-4, Research Results Digest No. 231, 1998.

