

Chapter Thirty-two
HORIZONTAL ALIGNMENT

BUREAU OF DESIGN AND ENVIRONMENT MANUAL

Chapter Thirty-two
HORIZONTAL ALIGNMENT

Table of Contents

<u>Section</u>	<u>Page</u>
32-1 DEFINITIONS	32-1.1
32-2 HORIZONTAL CURVES	32-2.1
32-2.01 Types of Horizontal Curves	32-2.1
32-2.01(a) General	32-2.1
32-2.01(b) Simple Curves	32-2.1
32-2.01(c) Compound Curves	32-2.1
32-2.01(d) Spiral Curves	32-2.1
32-2.01(e) Reverse Curves	32-2.2
32-2.01(f) Broken-Back Curves	32-2.2
32-2.02 General Theory	32-2.3
32-2.02(a) Ball-Bank Indicator	32-2.3
32-2.02(b) Basic Curve Equation	32-2.3
32-2.02(c) Theoretical Approaches	32-2.4
32-2.02(d) Superelevation	32-2.5
32-2.02(e) Side Friction	32-2.5
32-2.02(f) Distribution of Superelevation and Side Friction	32-2.5
32-2.03 Minimum Radii	32-2.6
32-2.04 Maximum Deflection Without Curve	32-2.6
32-2.05 Minimum Length of Curve	32-2.7
32-3 SUPERELEVATION DEVELOPMENT (OPEN ROADWAY CONDITIONS)	32-3.1
32-3.01 Superelevation Rates	32-3.1
32-3.01(a) Maximum Superelevation Rate	32-3.1
32-3.01(b) Superelevation Tables	32-3.1
32-3.01(c) Minimum Radii Without Superelevation	32-3.1
32-3.02 Transition Lengths	32-3.8
32-3.02(a) Two-Lane Highways	32-3.8
32-3.02(b) Multilane Highways	32-3.14
32-3.02(c) Application of Transition Length	32-3.16
32-3.03 Axis of Rotation	32-3.17
32-3.03(a) Two-Lane, Two-Way Highways	32-3.17

Table of Contents

(Continued)

<u>Section</u>		<u>Page</u>
	32-3.03(b) Multilane Divided Highways	32-3.18
	32-3.03(c) Multilane Highways with Narrow/Flush Medians.....	32-3.18
32-3.04	Shoulder Superelevation	32-3.18
	32-3.04(a) Shoulder (High Side of Curve)	32-3.19
	32-3.04(b) Shoulder (Low Side of Curve).....	32-3.19
32-3.05	Compound Curves.....	32-3.20
	32-3.05(a) Case I.....	32-3.20
	32-3.05(b) Case II.....	32-3.20
	32-3.05(c) Multilane Highways	32-3.21
32-3.06	Reverse Curves	32-3.21
32-3.07	Bridges	32-3.22
32-3.08	Typical Superelevation Figures	32-3.22
32-3.09	Examples.....	32-3.28
32-4	HORIZONTAL SIGHT DISTANCE	32-4.1
	32-4.01 Sight Obstruction (Definition).....	32-4.1
	32-4.02 Length > Sight Distance	32-4.1
	32-4.02(a) Stopping Sight Distance (SSD).....	32-4.1
	32-4.02(b) Other Sight Distance Criteria	32-4.4
	32-4.02(c) Entering/Exiting Portions (Typical Application)	32-4.4
	32-4.03 Length < Sight Distance	32-4.4
	32-4.04 Application	32-4.6
	32-4.05 Longitudinal Barriers.....	32-4.6
	32-4.06 Compound Curves.....	32-4.8
32-5	DESIGN CONTROLS	32-5.1
32-6	MATHEMATICAL DETAILS FOR HORIZONTAL CURVES	32-6.1
32-7	CURVE DATA	32-7.1
	32-7.01 Rounding	32-7.1
	32-7.02 Chord Distances	32-7.2
32-8	REFERENCES.....	32-8.1

Chapter Thirty-two

HORIZONTAL ALIGNMENT

Chapter 32 presents IDOT criteria for the design of horizontal alignment elements. This includes horizontal curvature, superelevation, sight distance around horizontal curves, and mathematical computations. Chapter 32 presents the information on horizontal alignment that has an application to several functional classes of highway. Where a horizontal alignment treatment only applies to a specific highway type, Part V, Design of Highway Types, presents this information. For example:

- Chapter 48 discusses horizontal alignment for low-speed urban streets ($V \leq 45$ mph (70 km/h)).
- Each of the functional classification chapters in Part V presents typical superelevated sections.

32-1 DEFINITIONS

This Section presents definitions for basic elements of horizontal alignment. Section 32-6 presents definitions and illustrations for mathematical details for horizontal curves (e.g., deflection angle (Δ), point of curvature (PC)).

1. Axis of Rotation. The line about which the pavement is revolved to superelevate the roadway. This line will maintain the normal highway profile throughout the curve.
2. Broken-Back Curves. Closely spaced horizontal curves with deflection angles in the same direction with an intervening, short tangent section (less than 1500 ft (500 m)).
3. Compound Curves. A series of two or more simple curves with deflections in the same direction immediately adjacent to each other.
4. Low-Speed Urban Streets. All streets within urbanized or small urban areas with a design speed of 45 mph (70 km/h) or less.
5. Maximum Side Friction (f_{\max}). Limiting values selected by AASHTO for use in the design of horizontal curves. The designated f_{\max} values represent a threshold of driver discomfort and not the point of impending skid.
6. Maximum Superelevation (e_{\max}). The maximum rate of superelevation (e_{\max}) is an overall superelevation control used on a widespread basis. Its selection depends on several factors including climatic conditions, terrain conditions, type of area (rural or urban), and highway functional classification.

7. Normal Crown (NC). The typical cross section on a tangent section of roadway (i.e., no superelevation).
8. Open Roadway Conditions. Rural facilities for all design speeds and urban facilities with a design speed ≥ 50 mph (80 km/h).
9. Relative Longitudinal Slope. For superelevation transition sections on two-lane facilities, the relative gradient between the centerline profile grade and edge of traveled way.
10. Remove Adverse Crown (RC). A superelevated roadway section that is sloped across the entire traveled way in the same direction and at a rate equal to the cross slope on the tangent section (typically, 3/16"/ft or 1/4"/ft (1.5% or 2%)).
11. Reverse Curves. Two simple curves with deflections in opposite directions that are joined by a relatively short tangent distance or that have no intervening tangent (i.e., the PT and PC are coincident).
12. Side Friction (f). The interaction between the tire and the pavement surface to counterbalance, in combination with the superelevation, the centrifugal force or lateral acceleration of a vehicle traversing a horizontal curve.
13. Simple Curves. Continuous arcs of constant radius that achieve the necessary highway deflection without an entering or exiting transition.
14. Spiral Curves. A transitional curve where the rate of curvature begins at $R = \infty$ (tangent) and gradually decreases to R , which is the curvature of a simple curve.
15. Superelevation (e). The amount of cross slope or "bank" provided on a horizontal curve to counterbalance, in combination with the side friction, the centrifugal force of a vehicle traversing the curve.
16. Superelevation Rollover. The algebraic difference (A) between the superelevated travel lane slope and shoulder slope on the high side of a horizontal curve.
17. Superelevation Transition Length. The distance required to transition the roadway from a normal crown section to the design superelevation rate. Superelevation transition length is the sum of the tangent runout (TR) and superelevation runoff (L) distances:
 - a. Tangent Runout (TR). Tangent runout is the distance needed to change from a normal crown section to a point where the adverse cross slope of the outside lane or lanes is removed (i.e., the outside lane(s) is level).
 - b. Superelevation Runoff (L). Superelevation runoff is the distance needed to change the cross slope from the end of the tangent runout (adverse cross slope removed) to a section that is sloped at the design superelevation rate (e).

32-2 HORIZONTAL CURVES

Horizontal curves are, in effect, transitions between two tangents. These deflectional changes are necessary in virtually all highway alignments to avoid impacts on a variety of field conditions (e.g., right-of-way, natural features, man-made features).

32-2.01 Types of Horizontal Curves

32-2.01(a) General

This section discusses the several types of horizontal curves that may be used to achieve the necessary roadway deflection. For each type, the discussion briefly describes the curve and presents the IDOT usage of the curve type. Section 32-6 presents detailed figures for the basic curve types (simple, compound, and spiral), and it presents the necessary details and mathematical equations for the typical applications of horizontal curves to highway alignment.

32-2.01(b) Simple Curves

Simple curves are continuous arcs of constant radius that achieve the necessary roadway deflection without an entering or exiting taper. The radius (R) defines the circular arc that a simple curve will transcribe. All angles and distances for simple curves are computed in a horizontal plane.

Because of their simplicity and ease of design, survey, and construction, IDOT typically uses the simple curve on highways.

32-2.01(c) Compound Curves

Compound curves are a series of two or more simple curves with deflections in the same direction. IDOT uses compound curves on highway mainline only to meet field conditions (e.g., to avoid obstructions that cannot be relocated) where a simple curve is not applicable and a spiral curve normally would not be used. Where a compound curve is used on a highway mainline, the radius of the flatter circular arc (R_1) should not be more than 50% greater than the radius of the sharper circular arc (R_2). In other words, $R_1 \leq 1.5 R_2$.

Chapter 36 discusses the use of compound curves for intersections (e.g., for curb radii, for turning roadways). Chapter 37 discusses the use of compound curves on interchange ramps.

32-2.01(d) Spiral Curves

Spiral curves provide an entering transition into a simple curve with a variable rate of curvature along its layout. As an option to a simple curve, a restricted horizontal alignment and high-

speed conditions may be conducive to the introduction of a spiral curve. Figure 32-2.A presents the guidelines for the use of spiral curves under these conditions. The parts of a spiral curve may be calculated with the use of the Department's approved computer software.

US Customary		Metric	
Design Speed (mph)	Maximum Radius (ft)	Design Speed (km/h)	Maximum Radius (m)
50	1265	80	379
55	1530	90	480
60	1820	100	592
65	2140	110	716
70	2480	120	852

Notes:

1. *Spiral curves are typically only used on new construction/reconstruction projects on freeways, expressways, and rural principal arterials.*
2. *Do not use spiral curves on bridges.*
3. *The benefits of spiral curve transitions are likely to be negligible for larger radii.*
4. *Maximum radius for use of a spiral is based on a minimum lateral acceleration rate of 4.25 ft/s² (1.3 m/s²).*

GUIDELINES FOR SPIRAL CURVES

Figure 32-2.A

32-2.01(e) Reverse Curves

Reverse curves are two simple curves with deflections in opposite directions that are joined by a relatively short tangent distance. In rural areas, a minimum of 500 ft (150 m) should be provided between the PT and PC of the two curves for appearance. Superelevation development for reverse curves requires special attention. This is discussed in Section 32-3.

32-2.01(f) Broken-Back Curves

Broken-back curves are closely spaced horizontal curves with deflection angles in the same direction with an intervening, short tangent section (less than 1500 ft (500 m) from PT to PC). Avoid broken-back curves on highway mainline because of the potential for confusing a driver, problems with superelevation development, and the unpleasant view of the roadway that is created. Instead, use a single, flat simple curve or, if necessary, a compound curve.

32-2.02 General Theory

This section summarizes the theoretical basis for the design of horizontal curves. For more information, the designer should refer to the latest edition of *AASHTO A Policy on Geometric Design of Highways and Streets*.

32-2.02(a) **Ball-Bank Indicator**

When a vehicle moves in a circular path, it is forced radially outward by centrifugal force. Figure 32-2.B illustrates the dynamics of a vehicle negotiating a horizontal curve, and it presents the geometry of the ball-bank indicator. This is a device that can be mounted on a vehicle in motion. The ball-bank reading indicates the combined effect of the body roll angle (ρ), centrifugal force angle (θ), and superelevation angle (ϕ). The centrifugal force is counterbalanced by the vehicle weight component related to the roadway superelevation or by the side friction developed between tires and surface or by a combination of the two.

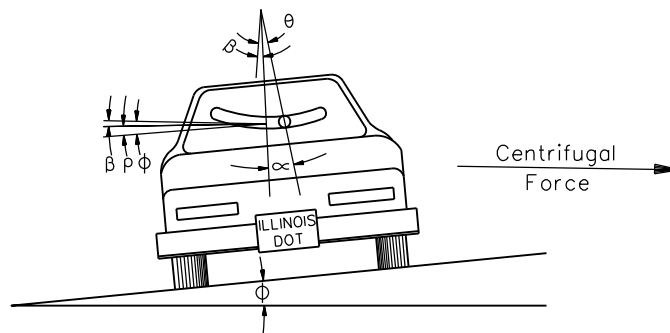

α = *Ball-bank indicator angle*

ρ = *Body roll angle*

θ = *Centrifugal force angle*

ϕ = *Superelevation angle*

β = $\phi - \rho$

GEOMETRY FOR BALL-BANK INDICATOR

Figure 32-2.B

32-2.02(b) **Basic Curve Equation**

The point-mass formula is used to define vehicular operation around a curve. Where the curve is expressed using its radius, the basic equation for a simple curve is:

$$R = \frac{V^2}{15(e + f)} \quad \text{(US Customary) Equation 32-2.1}$$

$$R = \frac{V^2}{127(e + f)} \quad \text{(Metric) Equation 32-2.1}$$

where: R = Radius of curve, ft (m)
 e = Superelevation rate, decimal
 f = Side-friction factor, decimal
 V = Vehicular speed, mph (km/h)

32-2.02(c) Theoretical Approaches

Establishing horizontal curvature criteria requires a determination of the theoretical basis for the various factors in the basic curvature equation (Equation 32-2.1). These include the set of side-friction factor (f) values and the distribution method between side friction and superelevation. The theoretical basis will be one of the following:

1. Open-Roadway Conditions. Open-roadway conditions apply to all rural facilities and to urban facilities where the design speed ($V \geq 50$ mph (80 km/h)). Open suburban highways may be designed for open roadway conditions if there is a good potential for such a highway becoming closed suburban in 10-15 years. The theoretical basis for horizontal curvature assuming open-roadway conditions includes:
 - relatively low side-friction factors (i.e., a relatively small level of driver discomfort; see Section 32-2.02(e)); and
 - the use of AASHTO Method 5 to distribute side friction and superelevation (see Section 32-2.02(f)).
2. Low-Speed Urban Streets. Low-speed urban streets are defined as streets within an urban or urbanized area where the design speed ($V \leq 45$ mph (70 km/h)). Chapter 48 presents the detailed criteria for horizontal alignment design on these facilities. The theoretical basis for horizontal curvature assuming low-speed urban street conditions includes:
 - relatively high side-friction factors to reflect a high level of driver acceptance of discomfort (see Section (32-2.02(e)); and
 - the use of AASHTO Method 2 to distribute side friction and superelevation (see Section 32-2.02(f)).
3. Turning Roadway Conditions. Turning roadway conditions typically apply to roadways at intersections. See Chapter 36. The theoretical basis for horizontal curvature assuming turning roadway conditions includes:
 - relatively high side-friction factors to reflect a higher level of driver acceptance of discomfort (see Section 32-2.02(e)); and

- a range of acceptable superelevation rates for combinations of curve radius and design speed to reflect the need for flexibility to meet field conditions for turning roadway design.

32-2.02(d) Superelevation

Superelevation allows a driver to negotiate a curve at a higher speed than would otherwise be comfortable. Superelevation and side friction work together to offset the outward pull of the vehicle as it traverses the horizontal curve. In highway design, it is necessary to establish limiting values of superelevation (e_{\max}) based on the operational characteristics of the facility. Section 32-3 discusses e_{\max} values for open-roadway conditions on new construction/reconstruction projects.

32-2.02(e) Side Friction

AASHTO has established limiting side-friction factors (f) for various design speeds; see Figure 32-2.C. It is important to realize that the f values used in design represent a threshold of driver discomfort and not the point of impending skid. As indicated in Figure 32-2.C, different sets of f values have been established for different operating conditions; see Section 32-2.02(c). The basis for the distinction is that drivers will accept different levels of discomfort for different operational conditions.

32-2.02(f) Distribution of Superelevation and Side Friction

As discussed above, the minimum radius is based on the e_{\max} and f_{\max} that apply to the facility. For curvature flatter than the minimum, a methodology must be applied to distribute superelevation and side friction for a given radius and design speed. The following describes the distribution methods:

1. Open-Roadway Conditions. Superelevation and side friction are distributed by AASHTO Method 5, which allows e and f to gradually increase in a curvilinear manner up to e_{\max} and f_{\max} . This method yields superelevation rates for which the superelevation counteracts nearly all centrifugal force at the average running speed and, therefore, considerable side friction is available for those drivers who are traveling near or above the design speed. Section 32-3 presents the superelevation rates which result from the use of Method 5.
2. Low-Speed Urban Streets. Superelevation and side friction are distributed by AASHTO Method 2, which allows f to increase up to f_{\max} before any superelevation is introduced. The practical effect of AASHTO Method 2 is that superelevation is rarely warranted on low-speed urban streets ($V \leq 45$ mph (70 km/h)). Chapter 48 presents the superelevation rates which result from the use of Method 2. For this method of distribution, the superelevation rates may be calculated directly from Equation 32-2.1 using $f = f_{\max}$.

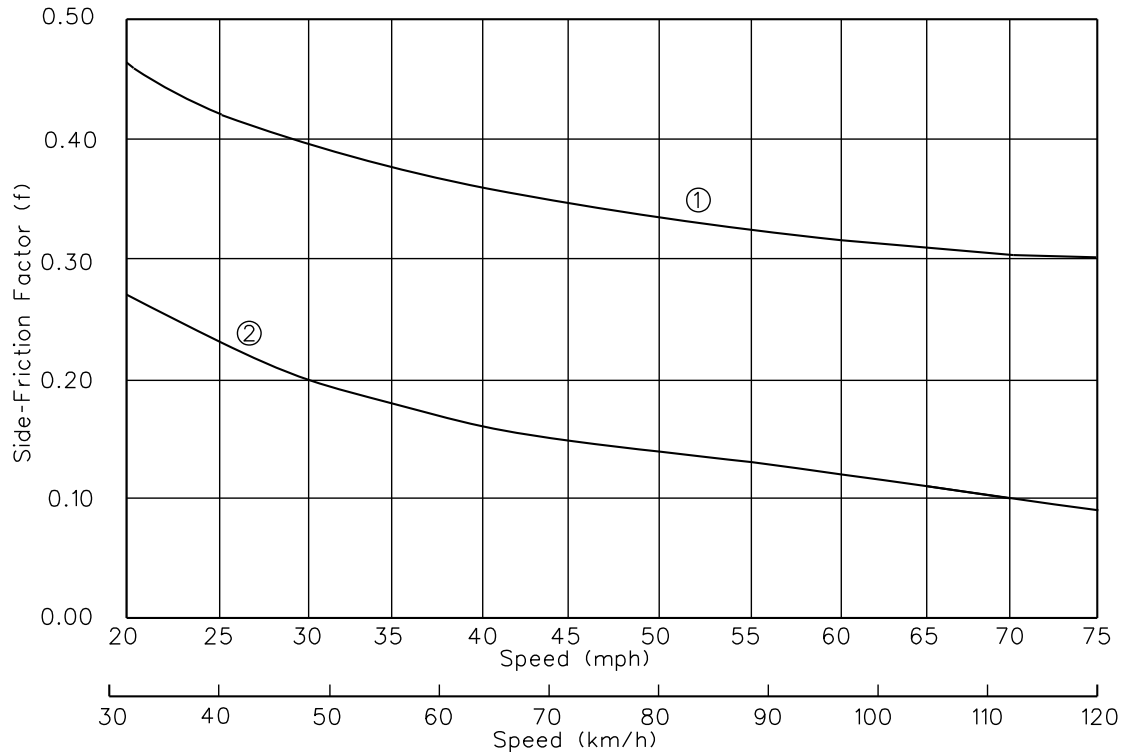

- ① Estimated point of impending skid assuming smooth tires and wet PCC pavement.
 ② Side-friction factors for design.

COMPARISON OF SIDE-FRICTION FACTORS (f)

Figure 32-2.C

32-2.03 Minimum Radii

The minimum radii is calculated from Equation 32-2.1 using the applicable values of e_{\max} and f_{\max} . In most cases, the designer should avoid the use of minimum radii because this results in the use of maximum superelevation rates. These rates are not desirable because the highway facility must accommodate vehicles traveling over a wide range of speeds. This is particularly true in Illinois where the entire State is subject to ice and snow, and the rate of superelevation should preclude vehicles that are stopped or traveling slowly from sliding down the cross slope when the pavement is icy. Figures 32-2.D ($e_{\max} = 8.0\%$), 32-2.E ($e_{\max} = 6.0\%$), and 32-2.F ($e_{\max} = 4.0\%$) present the minimum radii for open-roadway conditions.

32-2.04 Maximum Deflection Without Curve

It may be appropriate to omit a horizontal curve where very small deflection angles are present. As a guide, the designer may retain deflection angles of about 1° or less (urban) and $0^\circ 15'$ or

less (rural) on the highway mainline. For these angles, the absence of a horizontal curve should not affect aesthetics.

32-2.05 Minimum Length of Curve

For small deflection angles, horizontal curves should be sufficiently long to avoid the appearance of a kink. For aesthetics, a minimum 500 ft (150 m) length of curve for a 5° central angle will eliminate the sense of abruptness for speeds of 70 mph (110 km/h). For lower design speeds, however, a 500 ft (150 m) minimum length of curve is not required to eliminate the sense of abruptness, and this length would impose undue requirements on the horizontal curvature. The length of curve required to permit superelevation transition at a speed of 30 mph (50 km/h) is approximately 100 ft (30 m) at $e_{\max} = 8.0\%$. Assuming 100 ft (30 m) for 30 mph (50 km/h) and 500 ft (150 m) for 70 mph (110 km/h), Figure 32-2.G is produced by providing logical increments for minimum length of curve for a 5° central angle for the intermediate design speeds.

Where the central angle is less than 5°, the minimum length of curve may be less than the values in Figure 32-2.G. Figure 32-2.H provides approximate adjustments for smaller deflection angles.

For central deflection angles more than 5°, the radius should be used to calculate the length of curve using the following equation:

$$L = \frac{2\pi R\Delta}{360} \quad \text{Equation 32-2.2}$$

where: L = length of curve, ft (m)
Δ = deflection angle, degrees
R = radius of curve, ft (m)

US Customary			Metric		
Design Speed, V (mph)	f_{max} (for comfort)	Minimum Radii, R_{min}^* (ft)	Design Speed, V (km/h)	f_{max} (for comfort)	Minimum Radii, R_{min}^* (m)
20	0.27	76	30	0.28	20
25	0.23	134	40	0.23	41
30	0.20	214	50	0.19	73
35	0.18	314	60	0.17	113
40	0.16	444	70	0.15	168
45	0.15	587	80	0.14	229
50	0.14	758	90	0.13	304
55	0.13	960	100	0.12	394
60	0.12	1200	110	0.11	501
65	0.11	1480	120	0.09	667
70	0.10	1810			

MINIMUM RADII
($e_{max} = 8.0\%$, Open-Roadway Conditions)

Figure 32-2.D

US Customary			Metric		
Design Speed, V (mph)	f_{max} (for comfort)	Minimum Radii, R_{min}^* (ft)	Design Speed, V (km/h)	f_{max} (for comfort)	Minimum Radii, R_{min}^* (m)
20	0.27	81	30	0.28	21
25	0.23	144	40	0.23	43
30	0.20	231	50	0.19	79
35	0.18	340	60	0.17	123
40	0.16	485	70	0.15	184
45	0.15	643	80	0.14	252
50	0.14	833	90	0.13	336
55	0.13	1060	100	0.12	437
60	0.12	1330	110	0.11	560
65	0.11	1660	120	0.09	756
70	0.10	2040			

MINIMUM RADII
($e_{max} = 6.0\%$, Open-Roadway Conditions)

Figure 32-2.E

* (US Customary) $R_{min} = \frac{V^2}{15(e_{max} + f_{max})}$; values for design have been rounded to the nearest 1 ft.

* (Metric) $R_{min} = \frac{V^2}{127(e_{max} + f_{max})}$; values for design have been rounded to the nearest 1 m.

US Customary			Metric		
Design Speed, V (mph)	f _{max} (for comfort)	Minimum Radii, R _{min} * (ft)	Design Speed, V (km/h)	f _{max} (for comfort)	Minimum Radii, R _{min} * (m)
20	0.27	86	30	0.28	22
25	0.23	154	40	0.23	47
30	0.20	250	50	0.19	86
35	0.18	371	60	0.17	135
40	0.16	533	70	0.15	203
45	0.15	711	80	0.14	280
50	0.14	926	--	--	--

Note: The use of minimum radii for e_{max} = 4% is only intended for certain conditions as described in Figure 32-3.A.

*(US Customary) $R_{min} = \frac{V^2}{15(e_{max} + f_{max})}$; values for design have been rounded to the nearest 1 ft.

*(Metric) $R_{min} = \frac{V^2}{127(e_{max} + f_{max})}$; values for design have been rounded to the nearest 1 m.

MINIMUM RADII
(e_{max} = 4.0%, Open-Roadway Conditions)

Figure 32-2.F

US Customary			Metric		
Design Speed, V (mph)	Minimum Length of Curve, L (ft)	Curve Radius* (ft)	Design Speed, V (km/h)	Minimum Length of Curve, L (m)	Curve Radius* (m)
30	100	1145	50	30	344
35	150	1720	60	50	573
40	200	2290	70	70	802
45	250	2865	80	90	1031
50	300	3440	90	110	1260
55	350	4010	100	130	1490
60	400	4585	110	150	1719
65	450	5155	120	170	1948
70	500	5730			

* $R = \frac{360L}{2\pi\Delta}$

Note: Calculated values have been rounded to the nearest 5 ft (1 m) increment. In all cases, the designer must consider the length of superelevation runoff in conjunction with the minimum length of curve. Under certain conditions, this may increase the minimum length of curve.

MINIMUM LENGTHS OF CURVE
(Δ = 5°)

Figure 32-2.G

Central Deflection Angle * (Δ)	Adjustment Factor Applied to Figure 32-2.G
5°	1.00
4°	0.80
3°	0.60
2°	0.40
1°	0.20

* For intermediate central deflection angles, use a straight-line interpolation.

**ADJUSTMENTS FOR MINIMUM LENGTHS OF CURVE
($\Delta < 5^\circ$)**

Figure 32-2.H

32-3 SUPERELEVATION DEVELOPMENT (Open Roadway Conditions)

This section presents IDOT criteria for superelevation development when using open-roadway conditions. These types of facilities generally exhibit relatively uniform traffic operations. Therefore, for superelevation development, the flexibility normally exists to design horizontal curves with the more conservative AASHTO Method 5 (for distribution of superelevation and side friction) and by providing gentler superelevation transition lengths. This will maximize driver comfort and safety. The following sections present the specific design criteria for superelevation rates and transition lengths assuming open-roadway conditions.

32-3.01 Superelevation Rates

32-3.01(a) Maximum Superelevation Rate

As discussed in Section 32-2, the selection of a maximum rate of superelevation (e_{max}) depends upon several factors. These include urban/rural location, type of existing or expected roadside development, type of traffic operations expected, and prevalent climatic conditions within Illinois. For open-roadway conditions on new construction/reconstruction projects, Figure 32-3.A identifies the selection of e_{max} .

32-3.01(b) Superelevation Tables

Based on the selection of e_{max} and the use of AASHTO Method 5 to distribute e and f , Figures 32-3.B, 32-3.C, and 32-3.D allow the designer to select the appropriate superelevation rate (e) for any combination of curve radius (R) and design speed (V). Note that the superelevation rates in the tables are expressed as percents, which is the accepted presentation on construction plans. For the equations in which superelevation is included (e.g., superelevation runoff equation, point-mass equation for curve radius), e is expressed as a decimal (i.e., (e in %) \div 100).

32-3.01(c) Minimum Radii Without Superelevation

A horizontal curve with a very large radius does not require superelevation, and the normal crown section (NC) used on tangent can be maintained throughout the curve. On sharper curves for the same design speed, a point is reached where a superelevation rate of 1.5% across the total traveled way width is appropriate. Figures 32-3.B, 32-3.C, and 32-3.D provide the threshold (or minimum) radius for a normal crown section at various design speeds.

Type of Facility	Design Speed ⁴	e_{max}
Rural Highways	$V \geq 60$ mph ($V \geq 100$ km/h)	6.0%
Rural Two-Lane Directional or Semi-directional Roadways	$V \geq 55$ mph ($V \geq 90$ km/h)	6.0%
Rural Frontage Roads (Type A, B, or C)	$V \leq 55$ mph ($V \leq 90$ km/h)	8.0%
Rural Strategic Regional Arterials (SRAs)	$V = 60$ mph ($V = 100$ km/h)	6.0%
High Speed Urban Highways and Urban Two-Lane Directional or Semi-directional Roadways	$V \geq 50$ mph ($V \geq 80$ km/h)	6.0%
Open Suburban Likely to Become Closed Suburban Within Next 10 Years ^{1,2}	$V = 50$ mph ($V = 80$ km/h)	4.0%
Open Suburban Likely to Remain Open Suburban for Next 10 Years ¹	$V = 50$ or 55 mph ($V = 80$ or 90 km/h)	6.0%
Low-Speed, Wrap-Around Frontage Roads (Suburban Areas) and Realigned Township/County Roads Near State Route Intersections	$V = 25, 30, 35, 40, 45$ mph ($V = 40, 50, 60, 70$ km/h)	4.0%
Ramps	$V \leq 50$ mph ($V \leq 80$ km/h)	6.0% or 8.0% ³
Last Curve on Stop/Signal Controlled Exit Ramp Tying into Crossroad	$V \leq 40$ mph ($V \leq 60$ km/h)	6.0%

Notes:

1. See Section 43-2 for definitions of suburban types.
2. For low-speed urban conditions, see Section 48-5 for values of e_{max} .
3. With snow and ice conditions and considering stop and go traffic during rush hours, use a maximum superelevation of 6%.
4. For more information on selection of design speeds for different highway types, see the chapters in Part V and Chapters 36 and 37.

SELECTION OF E_{max}
(Open-Roadway Conditions)

Figure 32-3.A

e (%)	V = 20 mph		V = 25 mph		V = 30 mph		V = 35 mph		V = 40 mph		V = 45 mph		V = 50 mph		V = 55 mph		V = 60 mph		V = 65 mph		V = 70 mph	
	R(ft)	Rmin	R(ft)	Rmin	R(ft)	Rmin	R(ft)	Rmin	R(ft)	Rmin	R(ft)	Rmin	R(ft)	Rmin	R(ft)	Rmin	R(ft)	Rmin	R(ft)	Rmin	R(ft)	Rmin
NC	> 1640		> 2370		> 3240		> 4260		> 5410		> 6710		> 8150		> 9720		> 11,500		> 12,900		> 14,500	
1.5	1640	134	2370	134	3240	214	4260	314	5410	444	6710	587	8150	758	9720	960	11,500	1200	12,900	1480	14,500	1810
2.0	1190	134	1720	134	2370	214	3120	314	3970	444	4930	587	5990	758	7150	960	8440	1200	9510	1480	10,700	1810
2.2	1070	134	1550	134	2130	214	2800	314	3570	444	4440	587	5400	758	6450	960	7620	1200	8600	1480	9660	1810
2.4	959	134	1400	134	1930	214	2540	314	3240	444	4030	587	4910	758	5870	960	6930	1200	7830	1480	8810	1810
2.6	872	134	1280	134	1760	214	2320	314	2960	444	3690	587	4490	758	5370	960	6350	1200	7180	1480	8090	1810
2.8	796	134	1170	134	1610	214	2130	314	2720	444	3390	587	4130	758	4950	960	5850	1200	6630	1480	7470	1810
3.0	730	134	1070	134	1480	214	1960	314	2510	444	3130	587	3820	758	4580	960	5420	1200	6140	1480	6930	1810
3.2	672	134	985	134	1370	214	1820	314	2330	444	2900	587	3550	758	4250	960	5040	1200	5720	1480	6460	1810
3.4	620	134	911	134	1270	214	1690	314	2170	444	2700	587	3300	758	3970	960	4700	1200	5350	1480	6050	1810
3.6	572	134	845	134	1180	214	1570	314	2020	444	2520	587	3090	758	3710	960	4400	1200	5010	1480	5680	1810
3.8	530	134	784	134	1100	214	1470	314	1990	444	2360	587	2890	758	3480	960	4140	1200	4710	1480	5350	1810
4.0	490	134	729	134	1030	214	1370	314	1770	444	2220	587	2720	758	3270	960	3890	1200	4450	1480	5050	1810
4.2	453	134	678	134	955	214	1280	314	1660	444	2080	587	2560	758	3080	960	3670	1200	4200	1480	4780	1810
4.4	418	134	630	134	893	214	1200	314	1560	444	1960	587	2410	758	2910	960	3470	1200	3980	1480	4540	1810
4.6	384	134	585	134	834	214	1130	314	1470	444	1850	587	2280	758	2750	960	3290	1200	3770	1480	4310	1810
4.8	349	134	542	134	779	214	1060	314	1390	444	1750	587	2160	758	2610	960	3120	1200	3590	1480	4100	1810
5.0	314	134	499	134	727	214	991	314	1310	444	1650	587	2040	758	2470	960	2960	1200	3410	1480	3910	1810
5.2	284	134	457	134	676	214	929	314	1230	444	1560	587	1930	758	2350	960	2820	1200	3250	1480	3740	1810
5.4	258	134	420	134	627	214	870	314	1160	444	1480	587	1830	758	2230	960	2680	1200	3110	1480	3570	1810
5.6	236	134	387	134	582	214	813	314	1090	444	1390	587	1740	758	2120	960	2550	1200	2970	1480	3420	1810
5.8	216	134	358	134	542	214	761	314	1030	444	1320	587	1650	758	2010	960	2430	1200	2840	1480	3280	1810
6.0	199	134	332	134	506	214	713	314	965	444	1250	587	1560	758	1920	960	2320	1200	2710	1480	3150	1810
6.2	184	134	308	134	472	214	669	314	909	444	1180	587	1480	758	1820	960	2210	1200	2600	1480	3020	1810
6.4	170	134	287	134	442	214	628	314	857	444	1110	587	1400	758	1730	960	2110	1200	2490	1480	2910	1810
6.6	157	134	267	134	413	214	590	314	808	444	1050	587	1330	758	1650	960	2010	1200	2380	1480	2790	1810
6.8	146	134	248	134	386	214	553	314	761	444	990	587	1260	758	1560	960	1910	1200	2280	1480	2690	1810
7.0	135	134	231	134	360	214	518	314	716	444	933	587	1190	758	1480	960	1820	1200	2180	1480	2580	1810
7.2	125	134	214	134	336	214	485	314	672	444	878	587	1120	758	1400	960	1720	1200	2070	1480	2470	1810
7.4	115	134	198	134	312	214	451	314	628	444	822	587	1060	758	1320	960	1630	1200	1970	1480	2350	1810
7.6	105	134	182	134	287	214	417	314	583	444	765	587	980	758	1230	960	1530	1200	1850	1480	2230	1810
7.8	94	134	164	134	261	214	380	314	533	444	701	587	901	758	1140	960	1410	1200	1720	1480	2090	1810
8.0	76	134	134	134	214	214	314	314	444	444	587	587	758	758	960	960	1200	1200	1480	1480	1810	1810

NC = Normal Crown = 1.5%

■ = Superlevation rates for speeds in this range should only be used to check for existing curves to remain in place.

MINIMUM RADII (R) for DESIGN SUPERELEVATION RATES (e), DESIGN SPEEDS (V), and e_{max} = 8% (Open-Roadway Conditions - AASHTO Method 5)

Figure 32-3.B (US Customary)

e (%)	V = 30 km/h		V = 40 km/h		V = 50 km/h		V = 60 km/h		V = 70 km/h		V = 80 km/h		V = 90 km/h		V = 100 km/h		V = 110 km/h		V = 120 km/h		
	R(m)	R(m)	R(m)	R(m)	R(m)	R(m)	R(m)	R(m)	R(m)	R(m)	R(m)	R(m)	R(m)	R(m)	R(m)	R(m)	R(m)	R(m)	R(m)	R(m)	R(m)
NC	> 443	> 784	> 1090	> 1490	> 1970	> 2440	> 2970	> 3630	> 4180	> 4900											
1.5	443	784	1090	1490	1970	2440	2970	3630	4180	4900											
2.0	322	571	791	1090	1450	1790	2190	2680	3090	3640											
2.2	288	512	711	976	1300	1620	1980	2420	2790	3290											
2.4	261	463	644	885	1190	1470	1800	2200	2550	3010											
2.6	237	421	587	808	1080	1350	1650	2020	2340	2760											
2.8	216	385	539	742	992	1240	1520	1860	2160	2550											
3.0	199	354	496	684	916	1150	1410	1730	2000	2370											
3.2	183	326	458	633	849	1060	1310	1610	1870	2220											
3.4	169	302	425	588	790	988	1220	1500	1740	2080											
3.6	156	279	395	548	738	924	1140	1410	1640	1950											
3.8	144	259	368	512	690	866	1070	1320	1540	1840											
4.0	134	241	344	479	648	813	1010	1240	1450	1740											
4.2	124	224	321	449	608	766	948	1180	1380	1650											
4.4	115	208	301	421	573	722	895	1110	1300	1570											
4.6	106	192	281	395	540	682	847	1050	1240	1490											
4.8	96	178	263	371	509	645	803	996	1180	1420											
5.0	87	163	246	349	480	611	762	947	1120	1360											
5.2	78	148	229	328	454	579	724	901	1070	1300											
5.4	71	136	213	307	429	549	689	859	1020	1250											
5.6	65	125	198	288	405	521	656	819	975	1200											
5.8	59	115	185	270	382	494	625	781	933	1150											
6.0	55	106	172	253	360	469	595	746	894	1100											
6.2	50	98	161	238	340	445	567	713	857	1060											
6.4	46	91	151	224	322	422	540	681	823	1020											
6.6	43	85	141	210	304	400	514	651	789	982											
6.8	40	79	132	198	287	379	489	620	757	948											
7.0	37	73	123	185	270	358	464	591	724	914											
7.2	34	68	115	174	254	338	440	561	691	879											
7.4	31	62	107	162	237	318	415	531	657	842											
7.6	29	57	99	150	221	296	389	499	621	803											
7.8	26	52	90	137	202	273	359	462	579	757											
8.0	20	41	73	113	168	229	304	394	501	667											
	R _{min} = 20 m	R _{min} = 41 m	R _{min} = 73 m	R _{min} = 113 m	R _{min} = 168 m	R _{min} = 229 m	R _{min} = 304 m	R _{min} = 394 m	R _{min} = 501 m	R _{min} = 667 m											

NC = Normal Crown = 1.5%

■ = Superelevation rates for speeds in this range should only be used to check for existing curves to remain in place.

MINIMUM RADII (R) for DESIGN SUPERELEVATION RATES (e), DESIGN SPEEDS (V), and e_{max} = 8% (Open-Roadway Conditions - AASHTO Method 5)

Figure 32-3.B (Metric)

e (%)	V = 20 mph		V = 25 mph		V = 30 mph		V = 35 mph		V = 40 mph		V = 45 mph		V = 50 mph		V = 60 mph		V = 65 mph		V = 70 mph		
	R(ft)	R _{min}	R(ft)	R _{min}	R(ft)	R _{min}	R(ft)	R _{min}	R(ft)	R _{min}	R(ft)	R _{min}	R(ft)	R _{min}	R(ft)	R _{min}	R(ft)	R _{min}	R(ft)	R _{min}	
NC	> 1580		> 2290		> 3130		> 4100		> 5230		> 6480		> 7870		> 11,100		> 12,600		> 14,100		
1.5	1580	2290	2290	4100	4100	5230	5230	6480	6480	7870	7870	9410	9410	11,100	11,100	12,600	12,600	14,100	14,100		
2.0	1120	1630	1630	2950	2950	3770	3770	4680	4680	5700	5700	6820	6820	8060	8060	9130	9130	10,300	10,300		
2.2	991	1450	1450	2000	2000	2630	2630	3370	3370	4190	4190	5100	5100	7230	7230	8200	8200	9240	9240		
2.4	884	1300	1300	1790	1790	2360	2360	3030	3030	3770	3770	4600	4600	6540	6540	7430	7430	8380	8380		
2.6	791	1170	1170	1610	1610	2130	2130	2740	2740	3420	3420	4170	4170	5950	5950	6770	6770	7860	7860		
2.8	709	1050	1050	1460	1460	1930	1930	2490	2490	3110	3110	3800	3800	5440	5440	6200	6200	7030	7030		
3.0	635	944	944	1320	1320	1760	1760	2270	2270	2840	2840	3480	3480	4990	4990	5710	5710	6490	6490		
3.2	566	850	850	1200	1200	1600	1600	2080	2080	2600	2600	3200	3200	4600	4600	5280	5280	6010	6010		
3.4	498	761	761	1080	1080	1460	1460	1900	1900	2390	2390	2940	2940	4250	4250	4890	4890	5580	5580		
3.6	422	673	673	972	972	1320	1320	1740	1740	2190	2190	2710	2710	3940	3940	4540	4540	5210	5210		
3.8	358	583	583	864	864	1190	1190	1590	1590	2010	2010	2490	2490	3650	3650	4230	4230	4860	4860		
4.0	309	511	511	766	766	1070	1070	1440	1440	1840	1840	2300	2300	3390	3390	3950	3950	4550	4550		
4.2	270	452	452	684	684	960	960	1310	1310	1680	1680	2110	2110	2590	2590	3410	3410	4270	4270		
4.4	238	402	402	615	615	868	868	1190	1190	1540	1540	1940	1940	2400	2400	2920	2920	3440	3440		
4.6	212	360	360	555	555	788	788	1090	1090	1410	1410	1780	1780	2210	2210	2710	2710	3220	3220		
4.8	189	324	324	502	502	718	718	995	995	1300	1300	1640	1640	2050	2050	2510	2510	3000	3000		
5.0	169	292	292	456	456	654	654	911	911	1190	1190	1510	1510	1890	1890	2330	2330	2800	2800		
5.2	152	264	264	413	413	595	595	833	833	1090	1090	1390	1390	1750	1750	2160	2160	2610	2610		
5.4	136	237	237	373	373	540	540	759	759	995	995	1280	1280	1610	1610	1990	1990	2420	2420		
5.6	121	212	212	335	335	487	487	687	687	903	903	1160	1160	1470	1470	1830	1830	2230	2230		
5.8	106	186	186	296	296	431	431	611	611	806	806	1040	1040	1320	1320	1650	1650	2020	2020		
6.0	81	144	144	231	231	340	340	485	485	643	643	833	833	1060	1060	1330	1330	1660	1660		
		R _{min} = 81 ft	R _{min} = 144 ft	R _{min} = 231 ft	R _{min} = 340 ft	R _{min} = 485 ft	R _{min} = 643 ft	R _{min} = 833 ft	R _{min} = 1060 ft	R _{min} = 1330 ft	R _{min} = 1660 ft	R _{min} = 2040 ft									

NC = Normal Crown = 1.5%

MINIMUM RADII (R) for DESIGN SUPERELEVATION RATES (e), DESIGN SPEEDS (V), and e_{max} = 6%
(Open-Roadway Conditions - AASHTO Method 5)

Figure 32-3.C (US Customary)

e (%)	V = 30 km/h	V = 40 km/h	V = 50 km/h	V = 60 km/h	V = 70 km/h	V = 80 km/h	V = 90 km/h	V = 100 km/h	V = 110 km/h	V = 120 km/h	
	R(m)	R(m)	R(m)	R(m)	R(m)	R(m)	R(m)	R(m)	R(m)	R(m)	
NC	> 421	> 738	> 1050	> 1440	> 1910	> 2360	> 2880	> 3510	> 4060	> 4770	
1.5	421	738	1050	1440	1910	2360	2880	3510	4060	4770	
2.0	299	525	750	1030	1380	1710	2090	2560	2970	3510	
2.2	265	465	668	919	1230	1530	1880	2300	2670	3160	
2.4	236	415	599	825	1110	1380	1700	2080	2420	2870	
2.6	212	372	540	746	1000	1260	1540	1890	2210	2630	
2.8	190	334	488	676	910	1150	1410	1730	2020	2420	
3.0	170	300	443	615	831	1050	1290	1590	1870	2240	
3.2	152	269	402	561	761	959	1190	1470	1730	2080	
3.4	133	239	364	511	697	882	1100	1360	1600	1940	
3.6	113	206	329	465	640	813	1020	1260	1490	1810	
3.8	96	177	294	422	586	749	939	1170	1390	1700	
4.0	82	155	261	380	535	690	870	1090	1300	1590	
4.2	72	136	234	343	488	635	806	1010	1220	1500	
4.4	63	121	210	311	446	584	746	938	1140	1410	
4.6	56	108	190	283	408	538	692	873	1070	1330	
4.8	50	97	172	258	374	496	641	812	997	1260	
5.0	45	88	156	235	343	457	594	755	933	1190	
5.2	40	79	142	214	315	421	549	701	871	1120	
5.4	36	71	128	195	287	386	506	648	810	1060	
5.6	32	63	115	176	260	351	463	594	747	980	
5.8	28	56	102	156	232	315	416	537	679	900	
6.0	21	43	79	123	184	252	336	437	560	756	
		R _{min} = 21 m	R _{min} = 43 m	R _{min} = 79 m	R _{min} = 123 m	R _{min} = 184 m	R _{min} = 252 m	R _{min} = 336 m	R _{min} = 437 m	R _{min} = 560 m	R _{min} = 756 m

NC = Normal Crown = 1.5%

MINIMUM RADII (R) for DESIGN SUPERELEVATION RATES (e), DESIGN SPEEDS (V), and e_{max} = 6% (Open-Roadway Conditions - AASHTO Method 5)

Figure 32-3.C (Metric)

US CUSTOMARY

e (%)	V = 20 mph		V = 25 mph		V = 30 mph		V = 35 mph		V = 40 mph		V = 45 mph		V = 50 mph	
	R(ft)	R(ft)	R(ft)	R(ft)	R(ft)	R(ft)	R(ft)	R(ft)	R(ft)	R(ft)	R(ft)	R(ft)	R(ft)	R(ft)
NC	> 1410	> 2050	> 2830	> 3730	> 4770	> 5930	> 7220							
1.5	1410	2050	2830	3730	4770	5930	7220							
2.0	902	1340	1880	2490	3220	4040	4940							
2.2	723	1110	1580	2120	2760	3480	4280							
2.4	513	838	1270	1760	2340	2980	3690							
2.6	388	650	1000	1420	1930	2490	3130							
2.8	308	524	817	1170	1620	2100	2660							
3.0	251	433	681	982	1370	1800	2290							
3.2	209	363	576	835	1180	1550	1980							
3.4	175	307	490	714	1010	1340	1720							
3.6	147	259	416	610	865	1150	1480							
3.8	122	215	348	512	730	970	1260							
4.0	86	154	250	371	533	711	926							
	R _{min} = 86 ft	R _{min} = 154 ft	R _{min} = 250 ft	R _{min} = 371 ft	R _{min} = 533 ft	R _{min} = 711 ft	R _{min} = 926 ft							

METRIC

e (%)	V = 30 km/h		V = 40 km/h		V = 50 km/h		V = 60 km/h		V = 70 km/h		V = 80 km/h	
	R(m)	R(m)	R(m)	R(m)	R(m)	R(m)	R(m)	R(m)	R(m)	R(m)	R(m)	R(m)
NC	> 371	> 679	> 951	> 1310	> 1740	> 2170						
1.5	371	679	951	1310	1740	2170						
2.0	237	441	632	877	1180	1490						
2.2	187	363	534	749	1020	1290						
2.4	132	273	435	626	865	1110						
2.6	99	209	345	508	720	944						
2.8	79	167	283	422	605	802						
3.0	64	137	236	356	516	690						
3.2	54	114	199	303	443	597						
3.4	45	96	170	260	382	518						
3.6	38	81	144	222	329	448						
3.8	31	67	121	187	278	381						
4.0	22	47	86	135	203	280						
	R _{min} = 22 m	R _{min} = 47 m	R _{min} = 86 m	R _{min} = 135 m	R _{min} = 203 m	R _{min} = 280 m						

NC = Normal Crown = 1.5%

MINIMUM RADII (R) for DESIGN SUPERELEVATION RATES (e), DESIGN SPEEDS (V), and e_{max} = 4% (Open-Roadway Conditions - AASHTO Method 5)

Figure 32-3.D

32-3.02 Transition Lengths

As defined in Section 32-1, the superelevation transition length is the distance required to transition the roadway from a normal crown section to the full design superelevation rate. The superelevation transition length is the sum of the tangent runout distance (TR) and superelevation runoff length (L_1).

32-3.02(a) Two-Lane Highways

Superelevation Runoff

Figure 32-3.E presents the superelevation runoff lengths (L_1) for two-lane highways for various combinations of curve radii and design speed. These lengths are calculated using the following equation:

$$L_1 = (e)(W)(RS) \quad \text{Equation 32-3.1}$$

- where:
- L_1 = Calculated superelevation runoff length for a two-lane highway (assuming the axis of rotation is about the roadway centerline), ft (m)
 - e = Design superelevation rate, decimal
 - W = Width of rotation for one lane (assumed to be 12 ft (3.6 m))
 - RS = Reciprocal of relative longitudinal gradient between the profile grade and outside edge of two-lane highway (see Figure 32-3.F)

Tangent Runout

To ensure that the relative longitudinal gradient for the tangent runout (TR) will equal that for the superelevation runoff, the tangent runout distance should be calculated using the following equation:

$$TR = \frac{S_{\text{normal}}}{e} (L_1) \quad \text{Equation 32-3.2}$$

- where: S_{normal} = Travel lane cross slope on tangent, decimal

Superelevation Transition Length

Once the tangent runout (TR) distance is calculated, this distance is added to the design superelevation runoff length (L_1). The total equals the theoretical superelevation transition length used for design at an isolated horizontal curve.

e (%)	V = 20 mph		V = 25 mph		V = 30 mph		V = 35 mph		V = 40 mph		V = 45 mph	
	Number of lanes rotated. Note that 1 lane rotated is typical for a 2-lane highway, 2 lanes rotated is typical for a 4-lane highway.											
	1	2	1	2	1	2	1	2	1	2	1	2
	L ₁ (ft)	L ₁ (ft)	L ₁ (ft)	L ₁ (ft)	L ₁ (ft)	L ₁ (ft)	L ₁ (ft)	L ₁ (ft)	L ₁ (ft)	L ₁ (ft)	L ₁ (ft)	L ₁ (ft)
NC	0	0	0	0	0	0	0	0	0	0	0	0
2.0	32	49	34	51	36	55	39	58	41	62	44	67
2.2	36	53	38	57	40	60	43	64	45	68	49	73
2.4	39	58	41	62	44	66	46	70	50	74	53	80
2.6	42	63	45	67	47	71	50	75	54	80	58	87
2.8	45	68	48	72	51	77	54	81	58	87	62	93
3.0	49	73	51	77	55	82	58	87	62	93	67	100
3.2	52	78	55	82	58	88	62	93	66	99	71	107
3.4	55	83	58	88	62	93	66	99	70	105	75	113
3.6	58	87	62	93	66	98	70	104	74	111	80	120
3.8	62	92	65	98	69	104	73	110	78	118	84	127
4.0	65	97	69	103	73	109	77	116	83	124	89	133
4.2	68	102	72	108	77	115	81	122	87	130	93	140
4.4	71	107	76	113	80	120	85	128	91	136	98	147
4.6	75	112	79	118	84	126	89	133	95	142	102	153
4.8	78	117	82	124	88	131	93	139	99	149	107	160
5.0	81	122	86	129	91	137	97	145	103	155	111	167
5.2	84	126	89	134	95	142	100	151	107	161	115	173
5.4	87	131	93	139	98	148	104	156	111	167	120	180
5.6	91	136	96	144	102	153	108	162	116	173	124	186
5.8	94	141	100	149	106	159	112	168	120	180	129	193
6.0	97	146	103	154	109	164	116	174	124	186	133	200
6.2	100	151	106	160	113	170	120	180	128	192	138	206
6.4	104	156	110	165	117	175	124	185	132	198	142	213
6.6	107	160	113	170	120	181	128	191	136	204	147	220
6.8	110	165	117	175	124	186	131	197	140	211	151	226
7.0	113	170	120	180	128	192	135	203	144	217	155	233
7.2	117	175	124	185	131	197	139	209	149	223	160	240
7.4	120	180	127	190	135	202	143	214	153	229	164	246
7.6	123	185	130	196	139	208	147	220	157	235	169	253
7.8	126	190	134	201	142	213	151	226	161	241	173	260
8.0	130	194	137	206	146	219	155	232	165	248	178	266

Key:

- L₁ = Superelevation Runoff, ft
- V = Design speed, mph
- e = Superelevation rate, %
- NC = Normal Crown = 1.5%

SUPERELEVATION RUNOFF L₁ FOR HORIZONTAL CURVES

Figure 32-3.E (US Customary)

e (%)	V = 50 mph		V = 55 mph		V = 60 mph		V = 65 mph		V = 70 mph	
	Number of lanes rotated. Note that 1 lane rotated is typical for a 2-lane highway, 2 lanes rotated is typical for a 4-lane highway.									
	1	2	1	2	1	2	1	2	1	2
	L ₁ (ft)	L ₁ (ft)	L ₁ (ft)	L ₁ (ft)	L ₁ (ft)	L ₁ (ft)	L ₁ (ft)	L ₁ (ft)	L ₁ (ft)	L ₁ (ft)
NC	0	0	0	0	0	0	0	0	0	0
2.0	48	72	51	77	53	80	56	84	60	90
2.2	53	79	56	84	59	88	62	92	66	99
2.4	58	86	61	92	64	96	67	101	72	108
2.6	62	94	66	100	69	104	73	109	78	117
2.8	67	101	72	107	75	112	78	117	84	126
3.0	72	108	77	115	80	120	84	126	90	135
3.2	77	115	82	123	85	128	89	134	96	144
3.4	82	122	87	130	91	136	95	143	102	153
3.6	86	130	92	138	96	144	101	151	108	162
3.8	91	137	97	146	101	152	106	159	114	171
4.0	96	144	102	153	107	160	112	168	120	180
4.2	101	151	107	161	112	168	117	176	126	189
4.4	106	158	112	169	117	176	123	185	132	198
4.6	110	166	118	176	123	184	129	193	138	207
4.8	115	173	123	184	128	192	134	201	144	216
5.0	120	180	128	192	133	200	140	210	150	225
5.2	125	187	133	199	139	208	145	218	156	234
5.4	130	194	138	207	144	216	151	226	162	243
5.6	134	202	143	215	149	224	157	235	168	252
5.8	139	209	148	222	155	232	162	243	174	261
6.0	144	216	153	230	160	240	168	252	180	270
6.2	149	223	158	238	165	248	173	260	186	279
6.4	154	230	164	245	170	256	179	268	192	288
6.6	158	238	169	253	176	264	185	277	198	297
6.8	163	245	174	261	181	272	190	285	204	306
7.0	168	252	179	268	186	280	196	294	210	315
7.2	173	259	184	276	192	288	201	302	216	324
7.4	178	266	189	284	197	296	207	310	222	333
7.6	182	274	194	291	202	304	212	319	228	342
7.8	187	281	199	299	208	312	218	327	234	351
8.0	192	288	204	307	213	320	224	336	240	360

Key:

- L₁ = Superelevation Runoff, ft
- V = Design speed, mph
- e = Superelevation rate, %
- NC = Normal Crown = 1.5%

SUPERELEVATION RUNOFF L₁ FOR HORIZONTAL CURVES

Figure 32-3.E (US Customary)
(Continued)

e (%)	V = 30 km/h		V = 40 km/h		V = 50 km/h		V = 60 km/h		V = 70 km/h		V = 80 km/h	
	Number of lanes rotated. Note that 1 lane rotated is typical for a 2-lane highway, 2 lanes rotated is typical for a 4-lane highway.											
	1	2	1	2	1	2	1	2	1	2	1	2
	L ₁ (ft)	L ₁ (ft)	L ₁ (ft)	L ₁ (ft)	L ₁ (ft)	L ₁ (ft)	L ₁ (ft)	L ₁ (ft)	L ₁ (ft)	L ₁ (ft)	L ₁ (ft)	L ₁ (ft)
NC	0	0	0	0	0	0	0	0	0	0	0	0
2.0	10	14	10	15	11	16	12	18	13	20	14	22
2.2	11	16	11	17	12	18	13	20	14	22	16	24
2.4	11	17	12	19	13	19	14	22	16	24	17	26
2.6	12	19	13	20	14	21	16	23	17	26	19	28
2.8	13	20	14	22	15	23	17	25	18	28	20	30
3.0	14	22	15	23	16	24	18	27	20	29	22	32
3.2	15	23	16	25	17	26	19	29	21	31	23	35
3.4	16	24	18	26	18	28	20	31	22	33	24	37
3.6	17	26	19	28	19	29	22	32	24	35	26	39
3.8	18	27	20	29	21	31	23	34	25	37	27	41
4.0	19	29	21	31	22	32	24	36	26	39	29	43
4.2	20	30	22	32	23	34	25	38	28	41	30	45
4.4	21	32	23	34	24	36	26	40	29	43	32	48
4.6	22	33	24	36	25	37	28	41	30	45	33	50
4.8	23	34	25	37	26	39	29	43	31	47	35	52
5.0	24	36	26	39	27	41	30	45	33	49	36	54
5.2	25	37	27	40	28	42	31	47	34	51	37	56
5.4	26	39	28	42	29	44	32	49	35	53	39	58
5.6	27	40	29	43	30	45	34	51	37	55	40	60
5.8	28	42	30	45	31	47	35	52	38	57	42	63
6.0	29	43	31	46	32	49	36	54	39	59	43	65
6.2	30	45	32	48	33	50	37	56	41	61	45	67
6.4	31	46	33	49	35	52	38	58	42	63	46	69
6.6	32	47	34	51	36	53	40	60	43	65	48	71
6.8	33	49	35	53	37	55	41	61	45	67	49	73
7.0	34	50	36	54	38	57	42	63	46	69	50	76
7.2	34	52	37	56	39	58	43	65	47	71	52	78
7.4	35	53	38	57	40	60	44	67	48	73	53	80
7.6	36	55	39	59	41	62	46	69	50	75	55	82
7.8	37	56	40	60	42	63	47	70	51	77	56	84
8.0	38	57	41	62	43	65	48	72	52	79	58	86

Key:

- L₁ = Superelevation Runoff, ft
- V = Design speed, mph
- e = Superelevation rate, %
- NC = Normal Crown = 1.5%

SUPERELEVATION RUNOFF L₁ FOR HORIZONTAL CURVES

Figure 32-3.E (Metric)

e (%)	V = 90 km/h		V = 100 km/h		V = 110 km/h		V = 120 km/h	
	Number of lanes rotated. Note that 1 lane rotated is typical for a 2-lane highway, 2 lanes rotated is typical for a 4-lane highway.							
	1	2	1	2	1	2	1	2
	L ₁ (ft)	L ₁ (ft)	L ₁ (ft)	L ₁ (ft)	L ₁ (ft)	L ₁ (ft)	L ₁ (ft)	L ₁ (ft)
NC	0	0	0	0	0	0	0	0
2.0	15	23	16	25	18	26	19	28
2.2	17	25	18	27	19	29	21	31
2.4	18	28	20	29	21	32	23	34
2.6	20	30	21	32	23	34	25	37
2.8	21	32	23	34	25	37	27	40
3.0	23	35	25	37	26	40	28	43
3.2	25	37	26	39	28	42	30	45
3.4	26	39	28	42	30	45	32	48
3.6	28	41	29	44	32	47	34	51
3.8	29	44	31	47	33	50	36	54
4.0	31	46	33	49	35	53	38	57
4.2	32	48	34	51	37	55	40	60
4.4	34	51	36	54	39	58	42	62
4.6	35	53	38	56	40	61	44	65
4.8	37	55	39	59	42	63	45	68
5.0	38	58	41	61	44	66	47	71
5.2	40	60	42	64	46	69	49	74
5.4	41	62	44	66	47	71	51	77
5.6	43	64	46	69	49	74	53	80
5.8	44	67	47	71	51	76	55	82
6.0	46	69	49	74	53	79	57	85
6.2	48	71	51	76	54	82	59	88
6.4	49	74	52	78	56	84	61	91
6.6	51	76	54	81	58	87	62	94
6.8	52	78	56	83	60	90	64	97
7.0	54	81	57	86	61	92	66	99
7.2	55	83	59	88	63	95	68	102
7.4	57	85	60	91	65	98	70	105
7.6	58	87	62	93	67	100	72	108
7.8	60	90	64	96	69	103	74	111
8.0	61	92	65	98	70	105	76	114

Key:

- L₁ = Superelevation Runoff, ft
- V = Design speed, mph
- e = Superelevation rate, %
- NC = Normal Crown = 1.5%

SUPERELEVATION RUNOFF L₁ FOR HORIZONTAL CURVES

Figure 32-3.E (Metric)

(Continued)

US Customary		
Design Speed (mph)	1:RS	Edge of Traveled Way Slope Relative to Centerline G(%) (max.)*
20	1:135	0.74
25	1:143	0.70
30	1:152	0.66
35	1:161	0.62
40	1:172	0.58
45	1:185	0.54
50	1:200	0.50
55	1:213	0.47
60	1:222	0.45
65	1:233	0.43
70	1:250	0.40
Metric		
Design Speed (km/h)	1:RS	Edge of Traveled Way Slope Relative to Centerline G(%) (max.)*
30	1:133	0.75
40	1:143	0.70
50	1:150	0.65
60	1:167	0.60
70	1:182	0.55
80	1:200	0.50
90	1:213	0.47
100	1:227	0.44
110	1:244	0.41
120	1:263	0.38

$$* G(\%) = \frac{1}{RS} \times 100$$

Equation 32-3.3

Notes:

1. The relative longitudinal slopes are assumed to be measured between two lines set 12 ft (3.6 m) apart.
2. The gradients shown were derived from values contained in the AASHTO A Policy on Geometric Design of Highways and Streets.

RELATIVE LONGITUDINAL GRADIENTS**Figure 32-3.F**

32-3.02(b) Multilane Highways

There is a wide variety of potential typical cross sections for a multilane highway. The variables include:

- number of lanes in each direction;
- type of median;
- use of a uniform cross slope or a crowned section;
- for crowned sections, location of crown point; and
- use of variable cross slopes for individual travel lanes (e.g., the lanes not adjacent to the crown point may be sloped at a steeper rate than those adjacent to the crown).

In all cases, the first objective in superelevation development is to transition the highway from the typical cross section to a section that slopes at a uniform rate across the traveled way in the same direction. Regardless of the typical cross section on tangent, this transition must be achieved to meet certain criteria and principles, including:

1. Rate of Transition. The rate of transition (i.e., the relative longitudinal gradient) should be the same as that for the superelevation runoff. This requires that the runoff be calculated first and the resultant relative gradient be calculated for the runoff. Note that Equation 32-3.4 can be used to calculate the superelevation runoff (L_{ML}) for all multilane highways regardless of the typical section on tangent.
2. Point of Rotation. Section 32-3.03(b) discusses the axes of rotation for multilane highways, which is in many cases the two median edges. However, an “initial” axis of rotation (and sometimes more than one) must be selected to remove any crown and achieve a planar section. This will often be a point other than that used for the “primary” axes of rotation to transition from the uniform cross slope to the design superelevation rate.
3. Tangent Runout. The end of the tangent runout occurs where the outside travel lane(s) are level. Where this involves more than one travel lane, the length of the tangent runout must be consistent with the criteria in Figure 32-3.G, which varies the length of transition according to the number of lanes rotated. Also, note that the initial part of the superelevation runoff is used to transition from the end of the tangent runout to a roadway section with a uniform slope.

Number of Lanes Rotated	"C" Ratio
1	1.0
1.5	1.25
2	1.5
2.5	1.75
3	2.0
3.5	2.25

**"C" RATIO
(Adjustment Factor for Number of Lanes Rotated)**

Figure 32-3.G

Because of the many variables in superelevation development on multilane highways, the following discussion is predicated on the following roadway characteristics:

- a four-lane divided highway,
- a median type and width where Department practice is to rotate about the two median edges (see Section 32-3.03(b)), and
- a typical section on tangent where each roadway is crowned at the centerline.

Section 48-5 discusses superelevation development for a raised median section where each traveled way has a uniform slope away from the raised median.

Superelevation Runoff

The superelevation runoff distance for multilane highways is calculated by using the following equation:

$$L_{ML} = C \times L_1 \quad \text{Equation 32-3.4}$$

- where:
- L_{ML} = Superelevation runoff length for multilane highway, ft (m)
 - L_1 = Calculated superelevation runoff length for a two-lane highway (assuming rotation about the centerline), ft (m)
 - C = Ratio of runoff length for a multilane highway to L_1 (see Figure 32-3.G)

Tangent Runout

For multilane highways, the relative longitudinal gradient for the tangent runout should equal that for the superelevation runoff. This first requires the calculation of the gradient (or its reciprocal, RS) for the runoff:

$$G_{SR} = \frac{(2W)(e) - (S_{normal})(W)}{L_{ML}} \quad \text{Equation 32-3.5}$$

- where:
- G_{SR} = relative longitudinal gradient for superelevation runoff (at the outside edge of the traveled way), decimal
 - W = width of one travel lane, ft (m)
 - e = design superelevation rate, decimal
 - S_{normal} = travel lane cross slope on tangent, decimal
 - L_{ML} = superelevation runoff length for multilane highway, ft (m)
 - RS_{SR} = $(1/G_{SR})$ = reciprocal of relative longitudinal for superelevation runoff

Now, the tangent runout (TR_{ML}) can be calculated from the following equation:

$$TR_{ML} = (S_{normal})(W)(RS_{SR}) \quad \text{Equation 32-3.6}$$

Superelevation Transition Length

The theoretical superelevation transition length is the sum of the superelevation runoff and tangent runout distances. This length is used for design at an isolated horizontal curve.

32-3.02(c) Application of Transition Length

Once the superelevation runoff and tangent runout have been calculated, the designer must determine how to fit the length into the horizontal and vertical planes. The following will apply:

1. Simple Curves. Typically for new construction/reconstruction projects, 67% of the superelevation runoff length will be placed on the tangent and 33% on the curve. Exceptions to this practice may be necessary to meet field conditions. The generally accepted range is 60% - 80% on tangent and 40% - 20% on curve. In extreme cases (e.g., to avoid placing any superelevation transition on a bridge or approach slab), the superelevation runoff may be distributed 50% - 100% on the tangent and 50% - 0% on the curve. This will usually occur only in urban or suburban areas with highly restricted right-of-way conditions. When considering the tangent runout distance, this results in a distribution of the total superelevation transition length of approximately 75% on the tangent and 25% on the curve. IDOT also uses this approximate distribution ratio at isolated horizontal curves. However, because the distribution of the superelevation transition length is not an exact science, the ratio should be rounded up or down slightly (to the nearest 5 ft (1 m) increment) to simplify design and layout in construction.

2. Spiral Curves. The design superelevation runoff length is typically assumed to fit the spiral curve length (TS to SC and CS to ST). Therefore, all of the tangent runoff is placed on the tangent before the TS and after the ST.
3. Field Application (Vertical Profile). At the beginning and end of the superelevation transition length, angular breaks occur in the profile if not smoothed. Field personnel usually smooth these abrupt angular breaks out during construction. This is usually accomplished by visually adjusting the wire used to control the vertical and horizontal position of the bituminous concrete paver or slip-form paver.

As a guide, the vertical curve transitions, to eliminate angular breaks, should have a length in feet numerically equivalent to approximately the design speed in mph (in meters approximately 20% of design speed in km/h). In addition, designers should graphically or numerically investigate the transition areas to identify potential flat spots for drainage before finalizing construction plans.

4. Ultimate Development. If the proposed facility is planned for an ultimate development of additional lanes, the designer should, where practical, reflect this length in the initial superelevation transition application. For example, a four-lane divided facility may be planned for an ultimate six-lane divided facility. Therefore, the superelevation transition length for the initial four-lane facility should be consistent with the future requirements of the six-lane facility.
5. Typical Figures/Examples. Section 32-3.08 presents typical figures for superelevation development of tangent runoff and superelevation runoff for two-lane highways and different median types on multilane facilities. Section 32-3.09 presents two examples to illustrate superelevation development.

32-3.03 Axis of Rotation

The following discusses the axis of rotation for two-lane, two-way highways and multilane highways. Section 32-3.08 presents typical figures illustrating the application of the axis of rotation in superelevation development.

32-3.03(a) Two-Lane, Two-Way Highways

The axis of rotation will typically be about the centerline of the roadway on two-lane, two-way highways. This method will yield the least amount of elevation differential between the pavement edges and their normal profiles. Occasionally, it may be necessary to rotate the pavement about the inside or outside edge of the traveled way. This may be necessary to meet field conditions (e.g., drainage on a curbed facility, roadside development). Note that, in this case, two travel lane widths will be rotated, and the superelevation runoff should be lengthened according to Figure 32-3.G.

On a two-lane highway with an auxiliary lane (e.g., a climbing lane), the axis of rotation will typically be about the centerline of the two through lanes.

32-3.03(b) Multilane Divided Highways

The axis of rotation will typically be about the two median edges for a multilane divided facility with a concrete barrier, a raised curb median > 16 ft (5.0 m), or a depressed median ≥ 40 ft (12 m). When the median edges are used as the axes of rotation, the median will remain in the same horizontal plane throughout the curve.

Several highway features may significantly influence superelevation development for multilane divided highways. These could include guardrail, median barriers, drainage, and major at-grade intersections. If a major cross road intersection is present where the median width is 18 ft (5.5 m), 22 ft (7.0 m), 30 ft (9.5 m), or 36 ft (10.5 m), it is recommended that the entire cross section of the mainline be rotated about the centerline of the roadway. This method of rotation will provide better operations for cross road traffic.

The designer should carefully consider the intended function of all highway features and ensure that the superelevated section and selected axis of rotation does not compromise traffic operations. In addition, the designer should consider the likely ultimate development of the facility and select an axis of rotation that will lend itself to future expansion.

32-3.03(c) Multilane Highways with Narrow/Flush Medians

The following types of multilane highways should develop superelevation by rotating the roadway about its centerline:

- existing 4 ft (1.2 m) wide median or undivided multilane highways not planned for reconstruction;
- multilane highways with flush medians;
- proposed multilane highways with a 16 ft (5.0 m) wide traversable median;
- proposed multilane highways with a raised curb median equal to 16 ft (5 m); or
- all highways with proposed flush two-way, left-turn lane (TWLTL).

The raised curb median 16 ft (5 m) wide should only be considered in the reconstruction category where right-of-way is highly restricted.

32-3.04 Shoulder Superelevation

Figure 32-3.H illustrates the shoulder treatment on superelevated sections. The following discusses specific criteria.

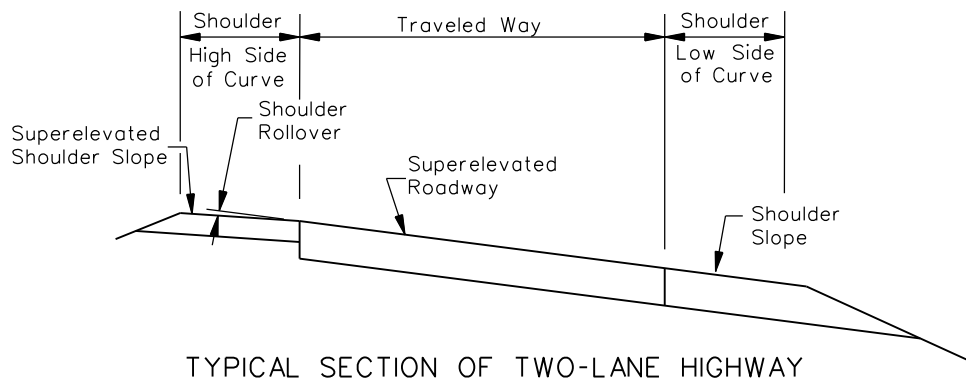

SHOULDER TREATMENT THROUGH SUPERELEVATED CURVE

Figure 32-3.H

32-3.04(a) Shoulder (High Side of Curve)

On the high side of superelevated sections, there will be a break in the cross slopes of the travel lane and shoulder. The following criteria will apply to this shoulder rollover:

1. Algebraic Difference. The rollover should not exceed 8.0% for new construction or reconstruction projects.
2. Minimum Shoulder Slope. On the high side of a curve, the shoulder slope may be designed for 0% so that maximum rollover is not exceeded. However, in this case, the longitudinal gradient at the edge of the traveled way should not be less than 0.5% for proper shoulder drainage.
3. Direction of Slope. If practical, the shoulder should slope away from the travel lane.
4. Shoulder as Deceleration Lane. Figure 36-2.J presents cross slope rollover criteria between a turning roadway and a through travel lane at an intersection. Where turning vehicles might use the shoulder, the designer may want to use the turning roadway rollover criteria (4.0% to 5.0%) rather than the 8.0% maximum rollover.

32-3.04(b) Shoulder (Low Side of Curve)

On the low side of a superelevated section, IDOT's typical practice is to retain the normal shoulder slope (4% typical) until the adjacent superelevated travel lane reaches that slope. The shoulder is then superelevated concurrently with the travel lane until the design superlevation rate is reached (i.e., the inside shoulder and travel lane will remain in a plane section).

32-3.05 Compound Curves

Superelevation development for compound curves requires the consideration of several factors. For two-lane roadways, these are discussed in the following sections for two Cases:

- Case I: The distance between the PC and PCC is 300 ft (90 m) or less.
- Case II: The distance between the PC and PCC is greater than 300 ft (90 m).

32-3.05(a) Case I

For Case I, superelevation development for compound curvature on two-lane roadways should meet the following objectives:

1. Relative Longitudinal Gradient (RS). A uniform RS should be provided throughout the superelevation transition (from normal crown section to design superelevation rate at the PCC).
2. Superelevation at PC. Section 32-3.02 will yield the design superelevation rate (e_1) for the first curve. At the PC, 67% e_1 should be reached.
3. Superelevation at PCC. The criteria in Section 32-3.02 will yield the design superelevation rate (e_2) for the second curve; e_2 should be reached at the PCC.
4. Superelevation Runoff Length. Section 32-3.02 will yield the superelevation runoff (L_1) for the first curve. The superelevation should be developed such that 67% of L_1 is reached at the PC.
5. Tangent Runout Length. TR will be determined as described in Section 32-3.02.

To meet all or most of these objectives, the designer may need to try several combinations of curve lengths, curve radii, and longitudinal gradients to find the most practical design. Section 32-3.08 presents a typical figure for Case I superelevation development for a compound curve.

32-3.05(b) Case II

For Case II, the distance between the PC and PCC (> 300 ft (90 m)) is normally large enough to allow the two curves to be evaluated individually. Therefore, the superelevation development on two-lane roadways should meet the following objectives for Case II:

1. First Curve. Superelevation should be developed assuming the curve is an independent simple curve. Therefore, the criteria in Section 32-3 for superelevation rate, transition length, and distribution between tangent and curve apply.
2. Intermediate Treatment. Superelevation for the first curve (e_1) is reached a distance of 33% of the superelevation runoff length beyond the PC. e_1 is maintained until it is necessary to develop the needed superelevation rate (e_2) for the second curve.

3. Second Curve. Assuming the second curvature has a sharper radius of curve than the first curve, a higher rate of superelevation will be required ($e_2 > e_1$). e_2 should be reached at the PCC. The distance needed for the additional superelevation development is not specified, except that the maximum RS for the highway design speed should not be exceeded. One logical treatment would be to apply the same RS used for the superelevation transition of the first curve. This would provide a uniform change in gradient for the driver negotiating the compound curve.

Section 32-3.08 presents a typical figure for Case II superelevation development for a compound curve.

32-3.05(c) Multilane Highways

Superelevation development for compound curvature on multilane highways should, as practical, be designed to:

- meet the principles of superelevation development for simple curves on multilane highways (see applicable criteria in Section 32-3); and
- meet the objectives for Case I or Case II as described for two-lane roadways.

The treatment for multilane highways will be determined on a case-by-case basis, reflecting individual site conditions.

32-3.06 Reverse Curves

Reverse curves are two closely spaced simple curves with deflections in opposite directions. For this situation, it may not be practical to achieve a normal crown section between the curves. A plane section continuously rotating about its axis (e.g., the centerline) can be maintained between the two curves, if they are close enough together. The designer should adhere to the applicable superelevation development criteria for each curve. The following will apply to reverse curves:

1. Normal Section. The designer should not attempt to achieve a normal tangent section between reverse curves unless the normal section can be maintained for a minimum of two seconds of travel time, and the superelevation transition requirements can be met for both curves. These criteria yield the following minimum tangent distance (between PT of first curve and PC of second curve) by using the following equation:

$$L_{\tan} \geq 0.67L_A + TR_A + 2(1.47V) + TR_B + 0.67L_B \quad (\text{US Customary}) \text{ Equation 32-3.7}$$

$$L_{\tan} \geq 0.67L_A + TR_A + 2(0.278V) + TR_B + 0.67L_B \quad (\text{Metric}) \text{ Equation 32-3.7}$$

where: L_{\tan} = Tangent distance between PT and PC, ft (m)
 L_A = Superelevation runoff length for first curve, ft (m)
 TR_A = Tangent runout length for first curve, ft (m)

- V = Design speed, mph (km/h)
TR_B = Tangent runout length for second curve, ft (m)
L_B = Superelevation runoff length for second curve, ft (m)

2. Continuously Rotating Plane. If a normal section is not provided, the pavement will be continuously rotated in a plane about its axis. In this case, the minimum distance between the PT and PC will be 67% of each superelevation runoff requirement added together. Use the following equation:

$$L_{\text{tan}} = 0.67L_A + 0.67L_B \quad \text{Equation 32-3.8}$$

where terms are as defined in No. 1 above.

Figure 32-3.1 illustrates superelevation development for reverse curves designed as a continuously rotating plane.

32-3.07 Bridges

Superelevation transitions should be avoided on bridges and their approaches. To achieve this in rural areas, the beginning of a horizontal curve should usually be a minimum of 400 ft (120 m) from the back of the bridge abutment. Where a curve is necessary on a bridge, the desirable treatment is to place the entire bridge and its approaches on a flat horizontal curve with minimum superelevation. In this case, a uniform superelevation rate is provided throughout (i.e., the superelevation transition is neither on the bridge nor its approaches). In some cases, however, superelevation transitions are unavoidable on urban bridges due to right-of-way constraints.

Where a bridge is located within a superelevated horizontal curve, the entire bridge roadway will be sloped in the same direction and at the same rate (i.e., the shoulder and travel lanes will be in a plane section). This also applies to the approach slab and approach slab shoulders before and after the back of the abutment. This is illustrated in Chapter 39. However, as discussed in Section 32-3.04, the high-side shoulder on a roadway section will slope away from the traveled way at a rate such that the maximum rollover does not exceed 8.0%.

Therefore, to not exceed the rollover criteria, it is necessary to transition the longitudinal shoulder slope adjacent to the roadway travel lanes to meet the shoulder slope adjacent to the travel lanes on the bridge. This transition should be accomplished by using a maximum relative longitudinal gradient of 0.40% between the edge of traveled way and outside edge of shoulder.

32-3.08 Typical Superelevation Figures

Figures 32-3.J through 32-3.M present superelevation development methods that will often be the most applicable to typical site conditions. Other superelevation methods or strategies may need to be developed on a case-by-case basis to meet specific field conditions. The acceptability of superelevation development methods other than those in the typical figures will be judged individually.

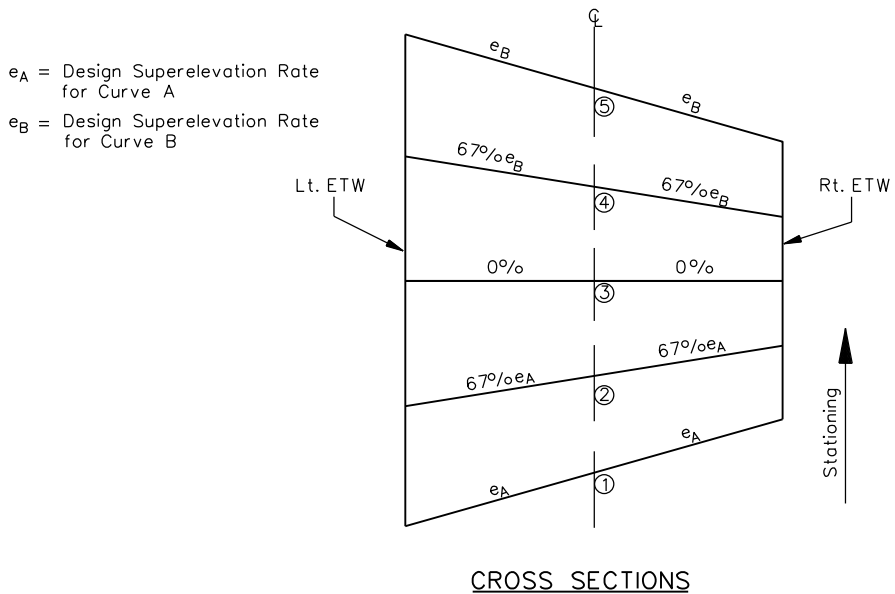
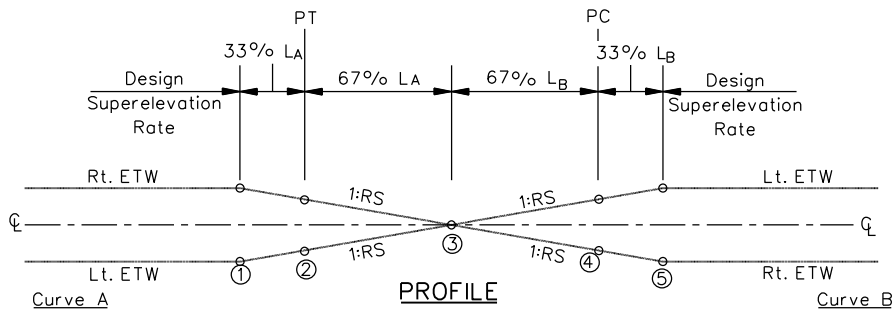
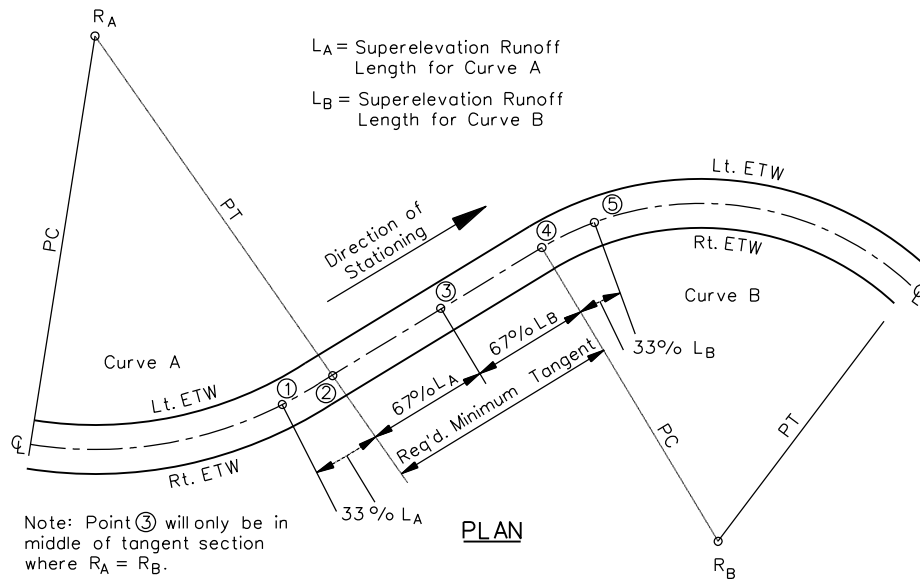

**SUPERELEVATION DEVELOPMENT FOR REVERSE CURVES
(Continuously Rotating Plane)**

Figure 32-3.I

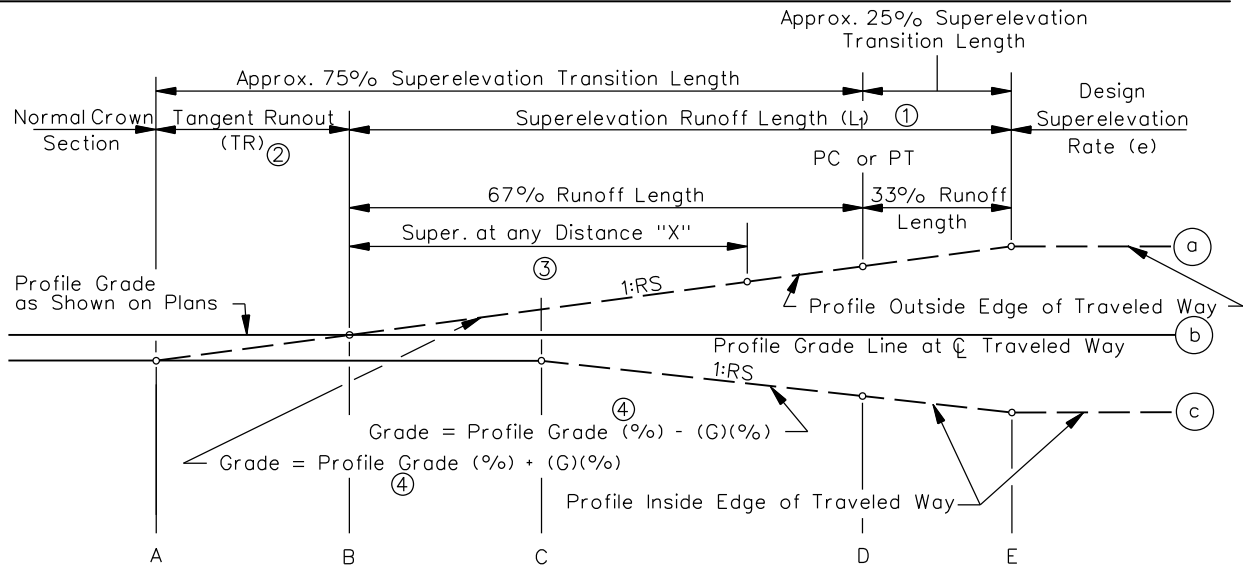

Note: Round all edge breakpoints in field.

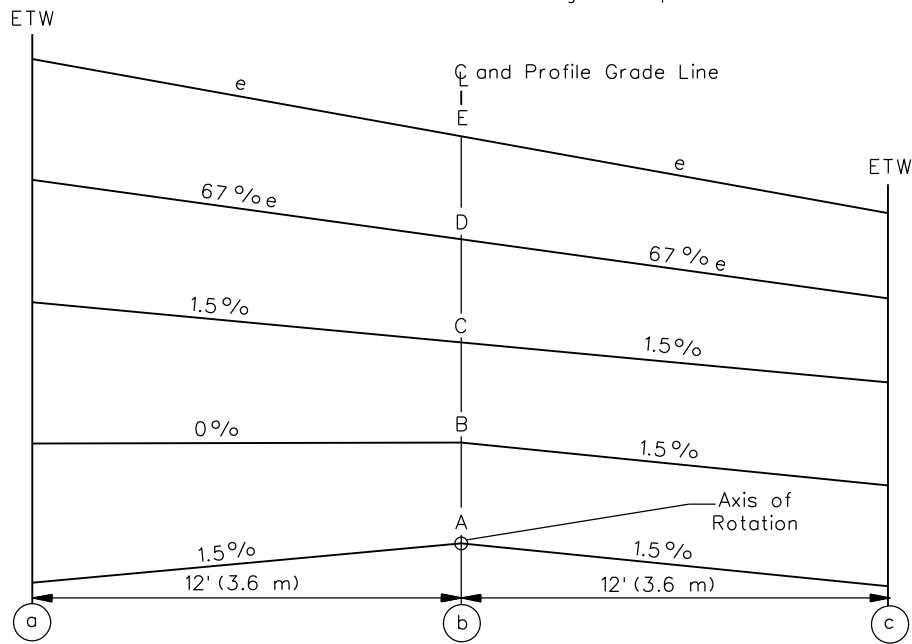

① $L_1 = e \times W \times RS$. See discussion on superlevation runoff calculations. The relative gradient of the superlevation runoff (G_{SR} , decimal) is:

$$G_{SR} = 12e/L_1 \quad (\text{US Customary})$$

$$G_{SR} = 3.6e/L_1 \quad (\text{Metric})$$

③ Superlevation rate (e) at any distance =

$$\frac{G_{SR} \times \text{Distance "X"}}{12} \quad (\text{US Customary})$$

$$\frac{G_{SR} \times \text{Distance "X"}}{36} \quad (\text{Metric})$$

② $TR = \frac{S_{normal}}{e} (L_1)$

④ Maximum Grade Difference $G(\%) = 1/RS \times 100$. The relative longitudinal gradients are assumed to be measured between two lines set 12 ft (3.6 m) apart.

**AXIS OF ROTATION ABOUT CENTERLINE
(Two-Lane Highway)**

Figure 32-3.J

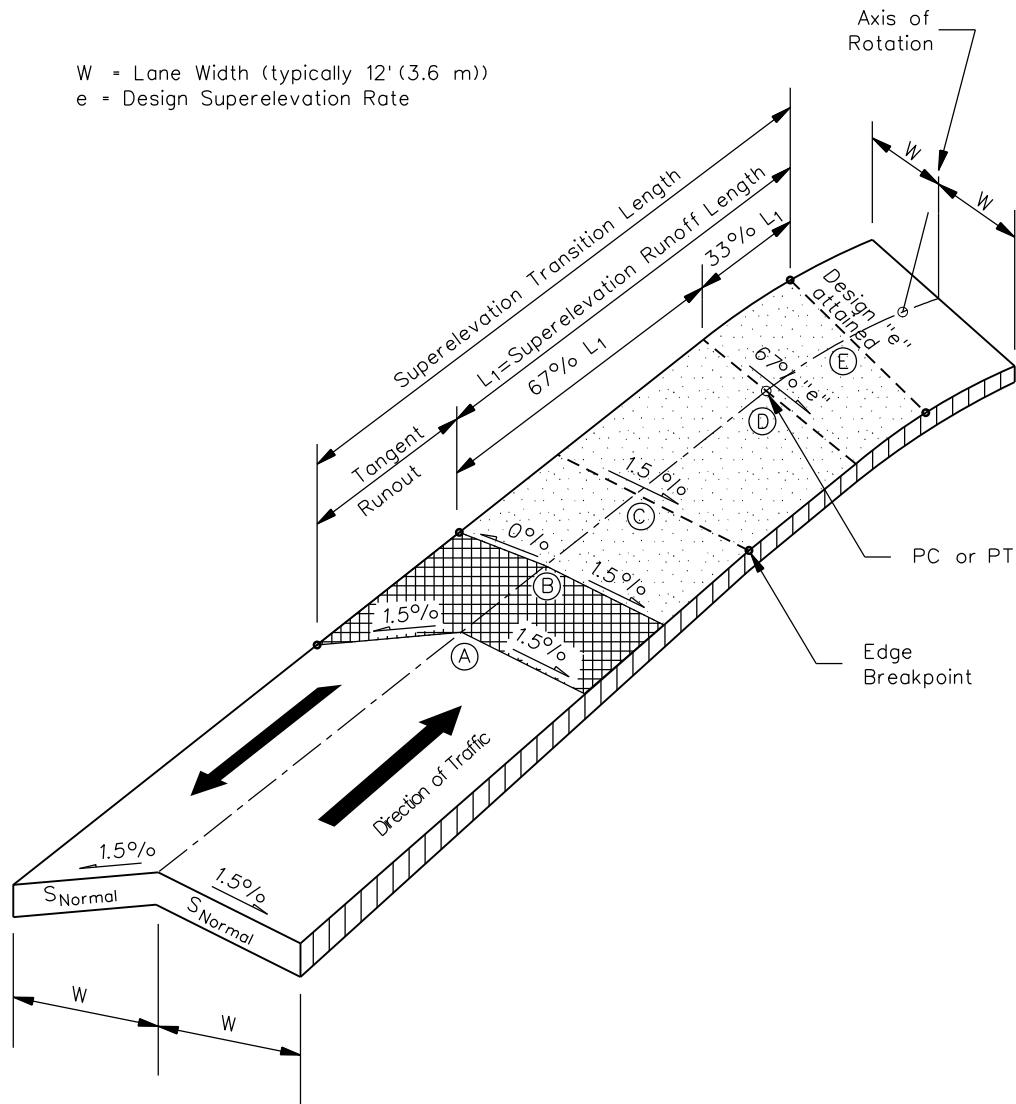

Note: Round all edge breakpoints in field.

**THREE-DIMENSIONAL VIEW OF SUPERELEVATION TRANSIT
 (Two-Lane Highway)**

Figure 32-3.K

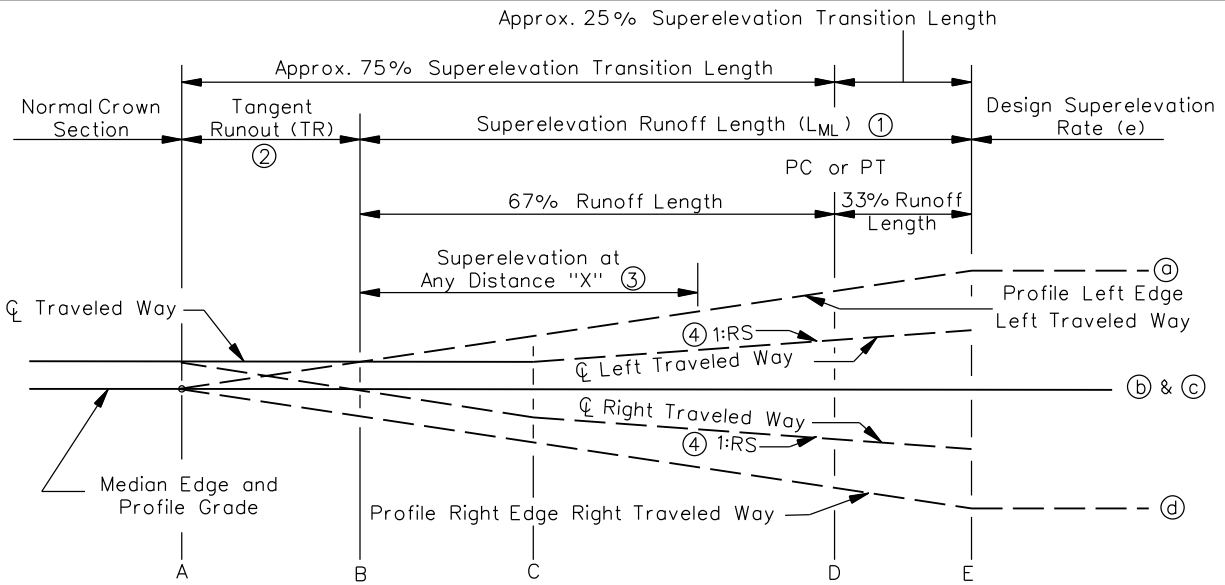

Note: Round all edge breakpoints in field.

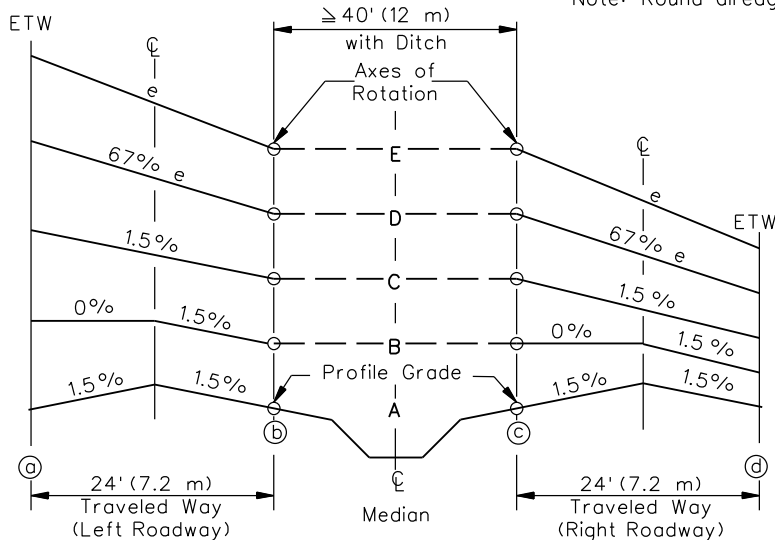

- ① $L_{ML} = L_1 \times C$. See discussion on superelevation runoff calculations. The relative gradient of the superelevation runoff (G_{SR} , decimal) is:

$$G_{SR} = \frac{(24)(e) - (0.015)(12)}{L_{ML}} \quad \text{(US Customary)}$$

$$G_{SR} = \frac{(7.2)(e) - (0.015)(3.6)}{L_{ML}} \quad \text{(Metric)}$$
- ② $TR_{ML} = \frac{(0.015)(12)}{G_{SR}} \quad \text{(US Customary)}$
 $TR_{ML} = \frac{(0.015)(3.6)}{G_{SR}} \quad \text{(Metric)}$

- ③ Superelevation rate at any distance:

$$\frac{G_{SR} \times \text{Distance "X"} + (0.015 \times 12)}{24} \quad \text{(US Customary)}$$

$$\frac{G_{SR} \times \text{Distance "X"} + (0.015 \times 3.6)}{7.2} \quad \text{(Metric)}$$

- ④ Maximum Grade Difference $G(\%) = 1/RS \times 100$. The relative longitudinal gradients are assumed to be measured between two lines set 12 ft (3.6 m) apart.

AXIS OF ROTATION ABOUT MEDIAN EDGES OF TRAVELED WAY (Multilane Divided Highways)

Figure 32-3.L

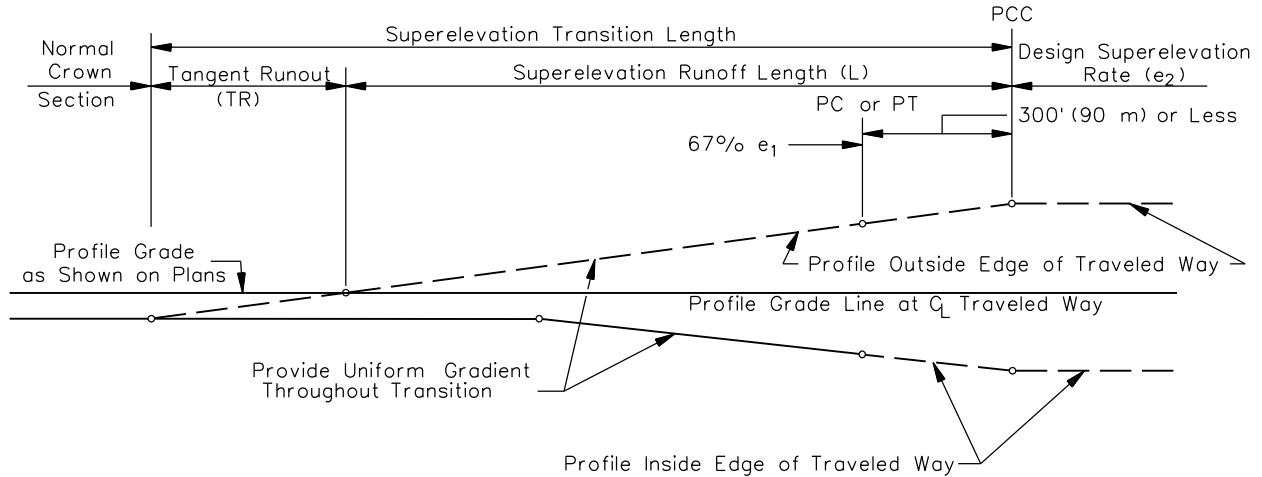

CASE I

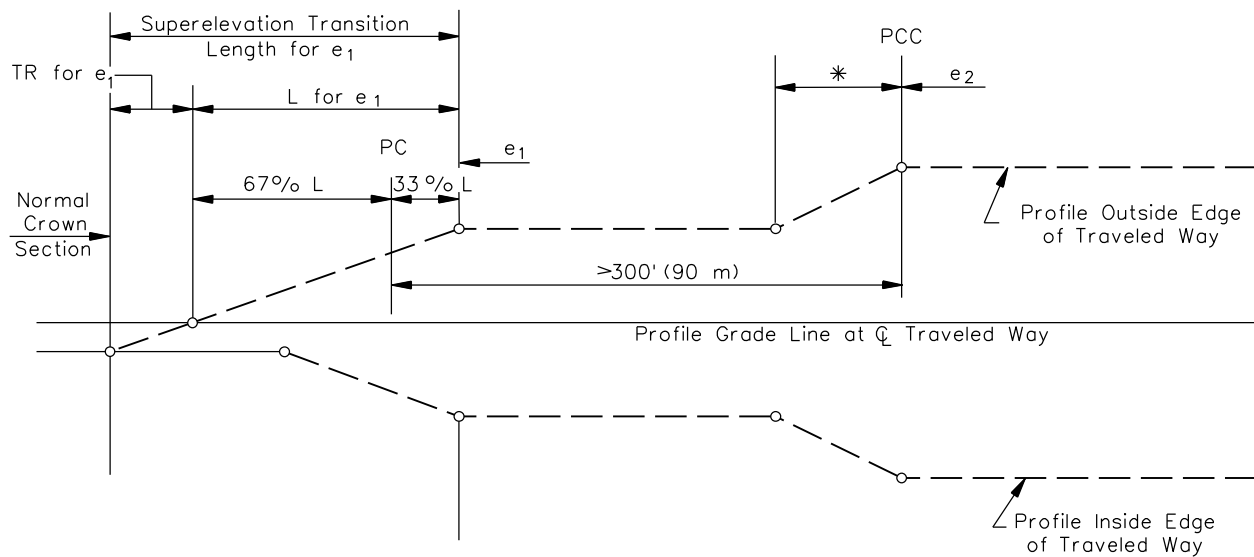

CASE II

* This distance may be determined by application of RS for the first curve to the increase in superelevation for the second curve (i.e., $e_2 - e_1$).

SUPERELEVATION DEVELOPMENT FOR COMPOUND CURVES

Figure 32-3.M

32-3.09 Examples

The following examples illustrate the application of the superelevation development criteria in Section 32-3.

Example 32-3.1

Given: Facility — New four-lane divided rural freeway
Travel lane cross slope = 3/16"/ft (on tangent) = 0.015 = S_{normal}
Crown at centerline of each roadway
Shoulder cross slope = 1/2"/ft (on tangent) = 0.04
Lane width = 12 ft
Inside shoulder width = 8 ft
Outside shoulder width = 10 ft
Median width = 56 ft
Design speed = 70 mph
 $R = 2500$ ft
PC = Station 65 + 50.00 (Curve to the right)

Note: Cross section A in Figure 32-3.N illustrates the typical tangent section.

Problem: With the axes of rotation about the median edges, determine the following details for superelevation development of the above horizontal curve:

- e_{max}
- design superelevation rate, e
- design superelevation runoff length, L_{ML}
- relative longitudinal gradients for superelevation runoff, G_{SR}
- tangent runout length, TR_{ML}
- shoulder rollover treatment, and
- reciprocal of relative longitudinal gradients (RS) between centerline and median edge of traveled way and between the two edges of the traveled way.

Solution: The details for the superelevated curve are determined as follows, and Figure 32-3.N presents the completed example and shows all stationing:

1. Determine e_{max} . Based on Figure 32-3.A, $e_{\text{max}} = 6.0\%$ for rural highways with open-roadway conditions ($V \geq 70$ mph).
2. Determine Design Superelevation Rate (e). From Figure 32-3.C, $e = 6.0\%$ for $R = 2500$ ft and $V = 70$ mph.

3. Determine Design Superelevation Runoff Length (L_{ML}).

For a divided highway with a median = 56 ft, rotate about the two median edges.

Based on Equation 32-3.4, runoff length (L_{ML}) is equal to (L_1) x (C).

From Figure 32-3.E, $L_1 = 180$ ft

From Figure 32-3.G, the "C" ratio for rotating two lanes about the median edge is = 1.5. Therefore: $L_{ML} = (L_1)(C) = (180)(1.5) = 270$ ft.

Distribution of L_{ML} is 67% (270) = 181 ft on tangent and 33% (270) = 89 ft on curve.

4. Determine Tangent Runout Length (TR).

Use Equation 32-3.5 to calculate the relative longitudinal gradient of the superelevation runoff:

$$G_{SR} = \frac{(2W)(e) - (S_{normal})(W)}{L_{ML}}$$

$$G_{SR} = \frac{(2)(12)(0.06) - (0.015)(12)}{270}$$

$$G_{SR} = 0.0046667 \quad RS_{SR} = (1/G_{SR}) = 214$$

Use Equation 32-3.6 to calculate the tangent runout:

$$TR_{ML} = (S_{normal})(W)(RS_{SR})$$

$$= (0.015)(12)(214)$$

$$= 38.52 \text{ ft} \approx 39 \text{ ft}$$

5. Determine Shoulder Rollover Treatment. Desirably, the maximum shoulder rollover on the high side of each curve should not exceed 8.0%. Therefore, with a shoulder cross slope of 4.0% on tangent, begin rotating the high-side shoulder where the travel lanes reach a superelevation rate of -0.040 (negative sign denotes downward slope away from the shoulder break). To determine where $e = 0.040$, use $G_{SR} = 0.0046667$ for the superelevation runoff length.

Next, use the equation in Note ③ from Figure 32-3.L and set the superelevation rate to 4% to calculate the distance X:

$$e_x = \frac{G_{SR} \times \text{Distance "X"} + (0.015 \times 12)}{24}$$

$$X = \frac{(24)(e_x) - (0.015 \times 12)}{G_{SR}}$$

$$X = \frac{(24)(0.04) - 0.18}{0.0046667}$$

$$X = 167.13 \text{ ft}$$

On the high-side of each roadway, the shoulder slope remains at 4% until the superelevation rate equals 4%, which will occur at 167.13 ft beyond the end of the tangent runout. Once 4% is attained, the high-side shoulder is rotated such that the shoulder rollover remains at 8% until reaching the design superelevation rate and remains at this slope through the curve. Where the superelevation reaches 6.0%, the shoulder will be sloped 2.0% away from the traveled way. See Figure 32-3.N for schematic details.

6. Determine Relative Longitudinal Slopes (RS). The RS values and relative gradients can be calculated using the basic equation:

$$RS = \frac{\text{Length of Transition}}{\Delta \text{ Elevation}}; G(\%) = \frac{1}{RS} \times 100$$

- a. Between Two Edges of Traveled Way.

As previously calculated in Step 4:

$$G = 0.0046667 = 0.47\%$$

$$RS = 214$$

- b. Between Median Edge and Centerline. Determine G_{CL} , which is the longitudinal gradient of the centerline relative to the median edge:

$$G_{CL} = \frac{(e \times W) - (\text{crosslope@Section C} - C \times W)}{\text{Length of slope along median edge}}$$

$$G_{CL} = \frac{(0.06 \times 12) - (0.015 \times 12)}{(181 - 78) + 89}$$

$$G_{CL} = \frac{0.72 - 0.18}{192} = 0.0028125 = 0.28\%$$

$$RS_{CL} = \left(\frac{1}{G_{CL}} \right) = 356$$

Example 32-3.2

Given: Facility — Four-lane divided highway with raised-curb median (open suburban area likely to become closed suburban within 10 years)

Travel lane width = 12 ft

Travel lane cross slope = 1/4"/ft (on tangent) = 0.02 = S_{normal}

Travel lanes all slope away from median edges

Gutter width = 2 ft

Gutter cross slope = 3/4"/ft (on tangent) = 0.06

Median gutter slopes towards median

Outside gutter slopes away from traveled way

Median width = 22 ft

Design speed = 50 mph and will post at 45 mph.

$R = 1800$ ft

PC = Station 65 + 50.00 (Curve to Right)

Superelevation runoff is distributed 67% on tangent and 33% on curve.

Note: Cross section A in Figure 32-3.O illustrates the tangent section.

Problem: With the axes of rotation about the median edges, determine the following details for superelevation development of the above horizontal curve:

- e_{max}
- design superelevation rate, e
- design superelevation runoff length, L_{ML}
- relative longitudinal gradient for superelevation runoff, G_{SR}
- tangent runout length, TR_{ML}
- gutter treatment, and
- reciprocal of relative longitudinal gradients (RS) between the two outside edges of traveled way and between the centerline and median edge of traveled way.

Solution: The details of the superelevated curve are determined as follows, and Figure 32-3.O presents the completed example and shows all stationing:

1. Determine e_{max} . Based on Figure 32-3.A, $e_{\text{max}} = 4.0\%$ for an open suburban area likely to become closed suburban within next 10 years ($V = 50$ mph).
2. Determine Design Superelevation Rate (e). From Figure 32-3.D, $e = 4.0\%$ for $R = 1800$ ft and $V = 50$ mph.

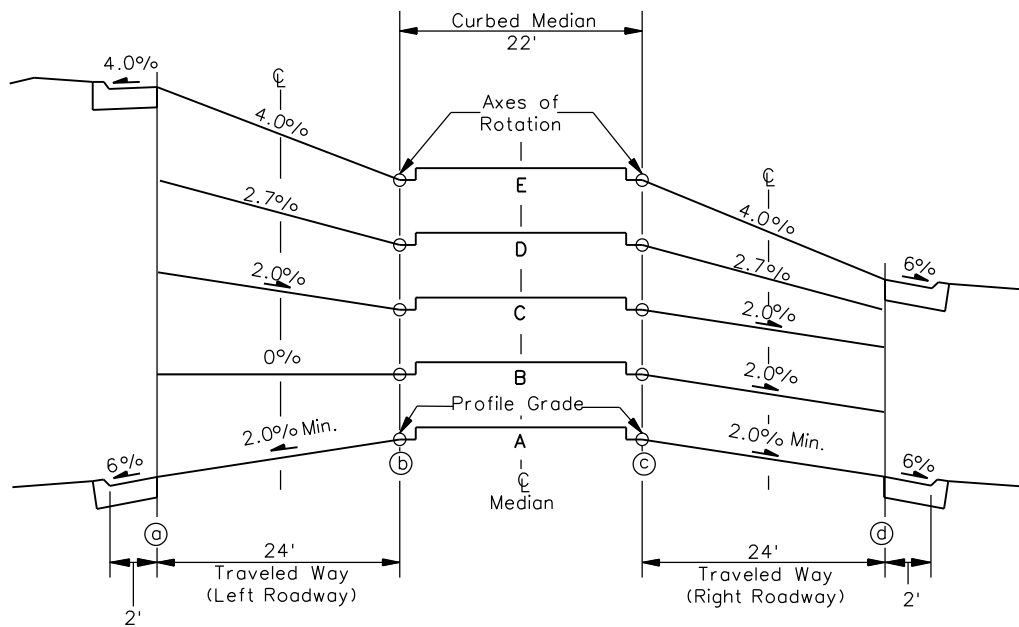
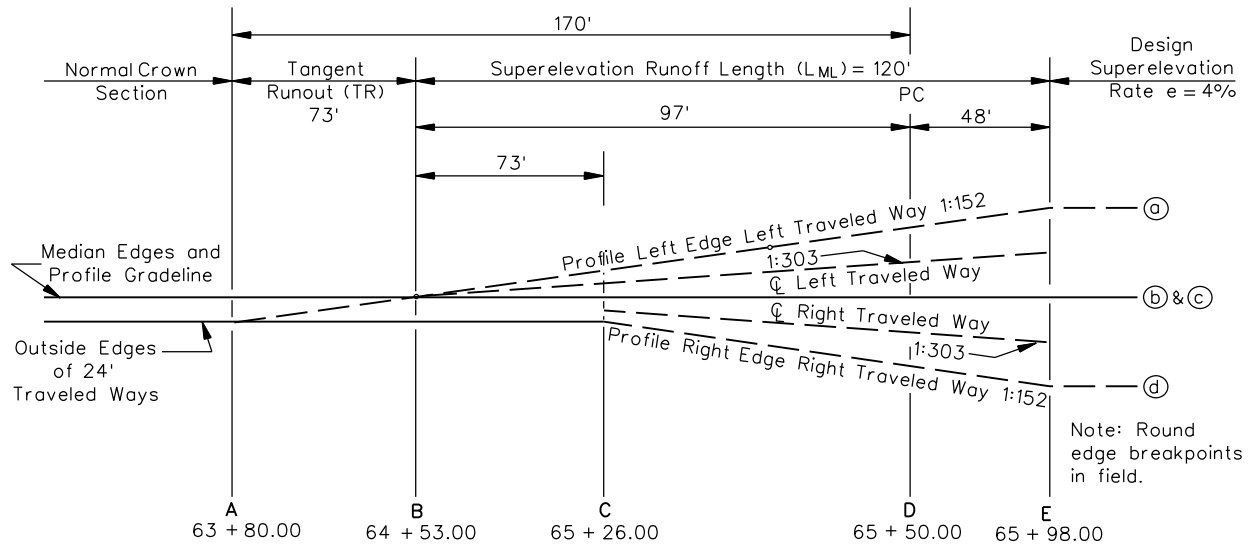

**AXIS OF ROTATION ABOUT MEDIAN EDGES
(Multilane Highway With Curbed Median)
(Example 32-3.2)**

Figure 32-3.O

3. Determine Design Superelevation Runoff Length (L_{ML}).

Based on Equation 32-3.4, runoff length (L_{ML}) is equal $(L_1) \times (C)$.

From Figure 32-3.E, $L_1 = 96$ ft.

From Figure 32-3.G, the "C" ratio for rotating two lanes about the median edge = 1.5. Therefore, $L_{ML} = (L_1)(C) = 96 \times 1.5 = 144$ ft. Use $L_{ML} = 145$ ft.

Distribution of L_{ML} is 67% $(145) = 97$ ft on tangent and 33% $(145) = 48$ ft on curve.

4. Determine Tangent Runout Length (TR). Because the typical section includes a uniform cross slope across the traveled way, modify Equation 32-3.2 for multilanes, using the runoff length (L_{ML}), and calculate the tangent runout (TR_{ML}):

$$TR_{ML} = \frac{S_{normal}}{e} (L_{ML})$$

$$TR_{ML} = \frac{0.02}{0.04} (145)$$

$$TR_{ML} = 72.5 \text{ ft} \approx 73 \text{ ft}$$

5. Determine Outside Gutter Treatment. On the low side of the roadway section, the slope of the outside gutter will remain at the standard 6% throughout the curve. On the high side of the roadway, the outside gutter is set at a maximum slope of 4% where full superelevation is attained. See Figure 48-5.E. Therefore, with a gutter slope of 6%, keep the high side gutter slope at 6% up to the location where the superelevation rate is 2% downward away from the gutter. To determine where $e = 2\%$, first use the equation in Note ① from Figure 48-5.F to determine the relative longitudinal gradient for the superelevation runoff length:

$$G_{SR} = \frac{24e}{L_{ML}} = \frac{(24)(0.04)}{145}$$

$$G_{SR} = 0.0066$$

$$RS_{SR} = (1/G_{SR}) = 152$$

Next, use the equation in Note ③ from Figure 48-5.E and set the superelevation rate to 2%. Calculate distance X:

$$e_x = \frac{G_{SR} \times \text{Distance "X"}}{24}$$

$$X = \frac{(24)(e_x)}{G_{SR}} = \frac{(24)(0.02)}{0.0066}$$

$$X = 72.73 \text{ ft}$$

On the high side of the outside roadway, the gutter slope remains at 6% until the superelevation rate equals 2%, which will occur at 72.73 ft beyond the end of the tangent runout. Once 2% is attained on the traveled way, the gutter is rotated up until reaching the location of the design superelevation rate. Where e reaches 4.0%, the gutter is sloped at 4.0% away from the traveled way and remains at this slope through the curve. See Figure 32-3.O.

6. Determine Relative Longitudinal Slopes (RS). The RS values and relative gradients can be calculated using the basic equation:

$$RS = \frac{\text{Length of Transition}}{\Delta \text{ Elevation}}; G(\%) = \frac{1}{RS} \times 100$$

- a. Between the Two Edges of Traveled Way. As previously calculated in Step 5:

$$G = 0.0066 = 0.66\%$$

$$RS = 152$$

- b. Between the Median Edge and Centerline. Determine G_{CL} , which is the longitudinal gradient of the centerline relative to the median edge:

$$G_{CL} = \frac{(e \times W_L) - (\text{crossslope @ Section C} - C \times W_L)}{\text{Length of slope along median edge}}$$

$$G_{CL} = \frac{(0.04 \times 12) - (0.02 \times 12)}{(97 - 72.73 \text{ ft}) + 48}$$

$$G_{CL} = \frac{0.48 - 0.24}{72.27} = 0.0033 = 0.33\%$$

$$RS_{CL} = \left(\frac{1}{G_{CL}} \right) = 303$$

32-4 HORIZONTAL SIGHT DISTANCE

32-4.01 Sight Obstruction (Definition)

Sight obstructions on the inside of a horizontal curve are defined as obstacles of considerable length which interfere with the line of sight on a continuous basis. These include walls, cut slopes, wooded areas, buildings, and high farm crops. In general, point obstacles such as traffic signs and utility poles are not considered sight obstructions on the inside of horizontal curves. The designer must examine each curve individually to determine whether it is necessary to remove an obstruction or adjust the horizontal alignment to obtain the required sight distance.

32-4.02 Length > Sight Distance

Where the length of curve (L) is greater than the sight distance (S) used for design, the needed clearance on the inside of the horizontal curve is calculated using the following equation:

$$HSO = R \left(1 - \cos \left[\frac{28.65S}{R} \right] \right) \quad \text{Equation 32-4.1}$$

where: HSO = Middle ordinate, or horizontal sightline offset from the center of the inside travel lane to the obstruction, ft (m)

R = Radius of curve, ft (m)

S = Sight distance, ft (m)

32-4.02(a) Stopping Sight Distance (SSD)

At a minimum, SSD will be available throughout the horizontal curve. The following discusses the application of SSD to sight distance at horizontal curves:

1. Passenger Cars (Level Grade). Figure 32-4.A provides the horizontal clearance criteria (i.e., horizontal sightline offset) for various combinations of stopping sight distance (see Figure 31-3.A) and curve radii for passenger cars on level grades. For those selections of S which fall outside of the figure (i.e., HSO > 40 ft (12 m) and/or R < 100 ft (50 m)), the designer should use Equation 32-4.1 to calculate the needed clearance.
2. Passenger Cars (Downgrade Adjustment). Figure 31-3.B presents SSD values for passenger cars adjusted for 3%-10% downgrades. If the downgrade on the facility is 3% or steeper, the designer should consider providing horizontal clearances adjusted for grade. These SSD values should be used directly in Equation 32-4.1 to calculate the horizontal sightline offset.

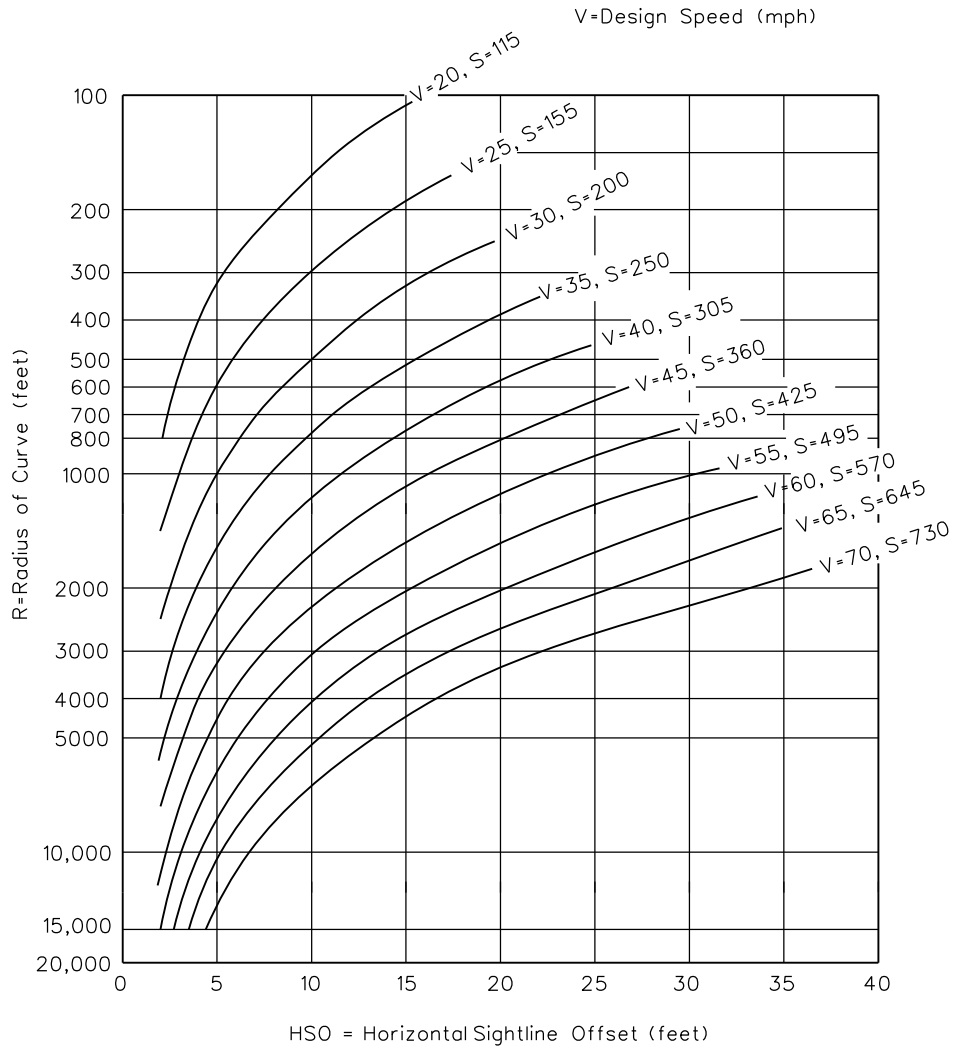
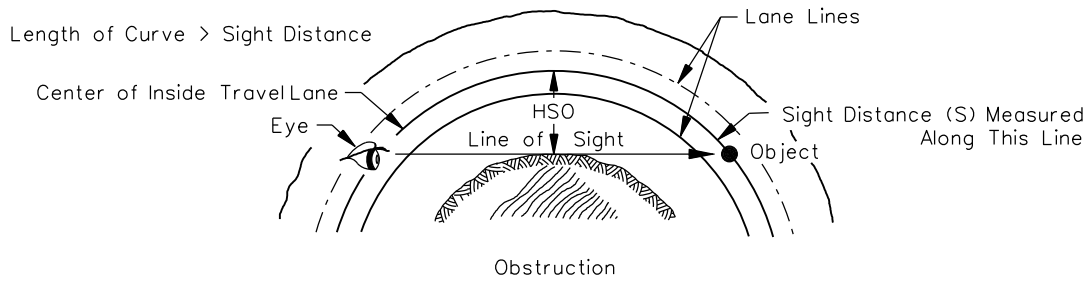

**SIGHT DISTANCE AT HORIZONTAL CURVES
(SSD) (US Customary)**

Figure 32-4.A

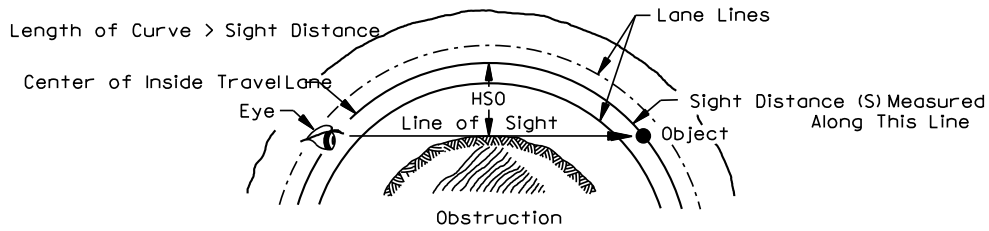

V=Design Speed (km/h)

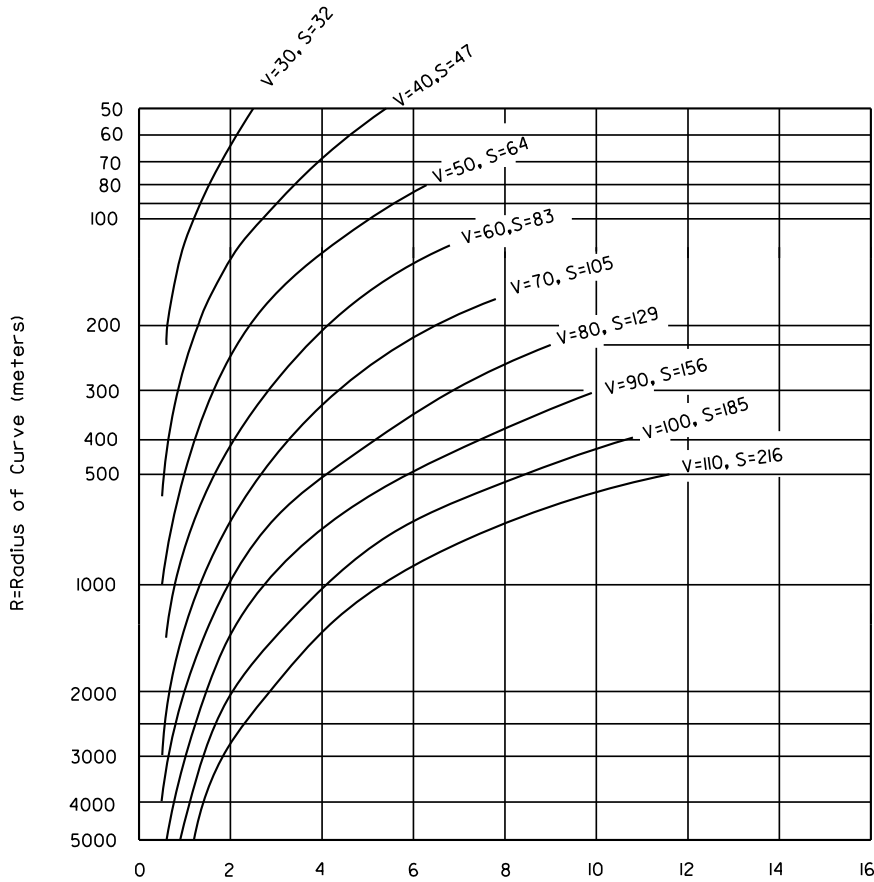

HSO = Horizontal Sight Line Offset (meters)

SIGHT DISTANCE AT HORIZONTAL CURVES (SSD) (Metric)

Figure 32-4.A

32-4.02(b) Other Sight Distance Criteria

At some locations, it may be warranted to provide SSD for decision sight distance or passing sight distance at the horizontal curve. Section 31-3 discusses candidate sites and provides design values for decision sight distance. Section 47-2 discusses passing sight distance on rural two-lane highways. These “S” values should be used in the basic equation to calculate “HSO” (Equation 32-4.1).

32-4.02(c) Entering/Exiting Portions (Typical Application)

The HSO values from Figure 32-4.A apply between the PC and PT. In addition, some transition is needed on the entering and exiting portions of the curve. The designer should typically use the following steps:

- Step 1: Locate the point which is on the outside edge of shoulder and a distance of $S/2$ before the PC.
- Step 2: Locate the point which is a distance HSO measured laterally from the center of the inside travel lane at the PC.
- Step 3: Connect the two points located in Steps 1 and 2. The area between this line and the roadway should be clear of all continuous obstructions.
- Step 4: A symmetrical application of Steps 1 through 3 should be used beyond the PT.

The example on Figure 32-4.B illustrates the determination of clearance requirements for the entering and exiting portions of a curve.

32-4.03 Length < Sight Distance

When the length of curve is less than the sight distance used in design, the HSO value from the basic equation will never be reached. As an approximation, the horizontal clearance for these curves should be determined as follows:

- Step 1: For the given R and S, calculate HSO assuming $L < S$.
- Step 2: The maximum HSO' value will be needed at a point of $L/2$ beyond the PC. Using Equation 32-4.2, HSO' is calculated from the following proportion:

$$\frac{\text{HSO}'}{\text{HSO}} = \frac{1.2L}{S}$$

$$\text{HSO}' = \frac{1.2(L)(\text{HSO})}{S}$$

Equation 32-4.2

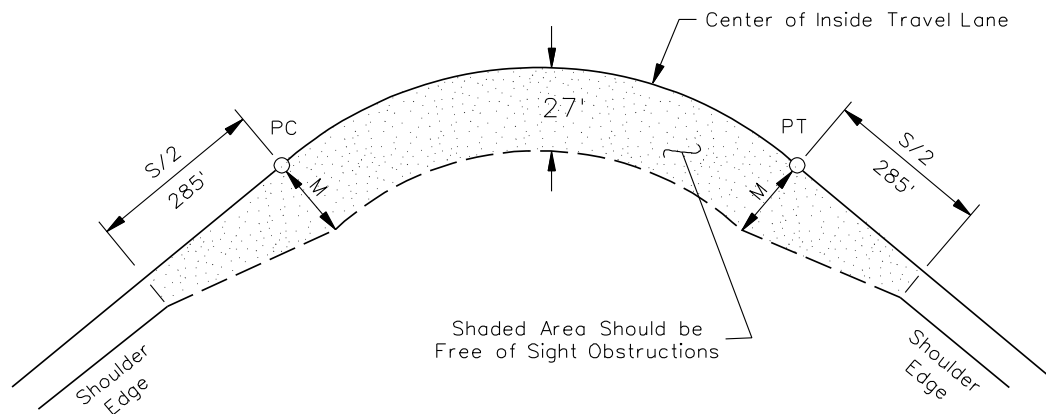

Example 32-4.1

Given: Design Speed = 60 mph
 R = 1500 ft
 Level Grade

Problem: Determine the horizontal sightline offset requirements for a horizontal curve on a two-lane highway assuming passenger car SSD.

$$HSO = R \left(1 - \cos \left[\frac{28.65 S}{R} \right] \right)$$

$$HSO = 1500 \left(1 - \cos \left[\frac{(28.65)(570)}{1500} \right] \right) = 27 \text{ ft}$$

Solution: Figure 31-3.A yields a SSD = 570 ft. Using Equation 32-4.1 for horizontal clearance ($L > S$):

This answer is verified by Figure 32-4.A.

The above figure also illustrates the horizontal clearance requirements for the entering and exiting portion of the horizontal curve.

SIGHT CLEARANCE REQUIREMENTS FOR HORIZONTAL CURVES ($L > S$)

Figure 32-4.B

- where:
- HSO' = Horizontal sightline distance for a curve where $L < S$, ft (m)
 - HSO = Horizontal sightline distance for the curve based on Equation 32-4.1, ft (m)
 - L = Length of the curve, ft (m)
 - S = Sight distance, ft (m)

- Step 3: Locate the point which is on the outside edge of shoulder and a distance of $S/2$ before the PC.
- Step 4: Connect the two points located in Steps 2 and 3. The area between this line and the roadway should be clear of all continuous obstructions.
- Step 5: A symmetrical application of Steps 2-4 should be used on the exiting portion of curve.

The Example on Figure 32-4.C illustrates the determination of clearance requirements for the entering and exiting portions of a curve where $L < S$.

32-4.04 Application

For sight distance applications at horizontal curves, the height of eye is 3.5 ft (1080 mm) and the height of object is 2 ft (600 mm). Both the eye and object are assumed to be in the center of the inside travel lane. The line-of-sight intercept with the obstruction is at the midpoint of the sightline and 2.75 ft (840 mm) above the center of the inside lane.

32-4.05 Longitudinal Barriers

Longitudinal barriers (e.g., bridge rails, guardrail, concrete barrier) can cause sight distance problems at horizontal curves because barriers are placed relatively close to the travel lane (often, 10 ft (3 m) or less) and because their height may be greater than 2.75 ft (840 mm).

The designer should check graphically the line of sight over a barrier along a horizontal curve and determine what height of object can actually be discerned. If this is higher than 2.75 ft (840 mm), the designer should attempt, if practical, to locate the barrier so that it does not block the line of sight. The following should be considered:

1. Superelevation. A superelevated roadway will elevate the driver's eye and, therefore, improve the line of sight over the barrier.
2. Barrier Height. The higher the barrier, the more obstructive it will be to the line of sight.

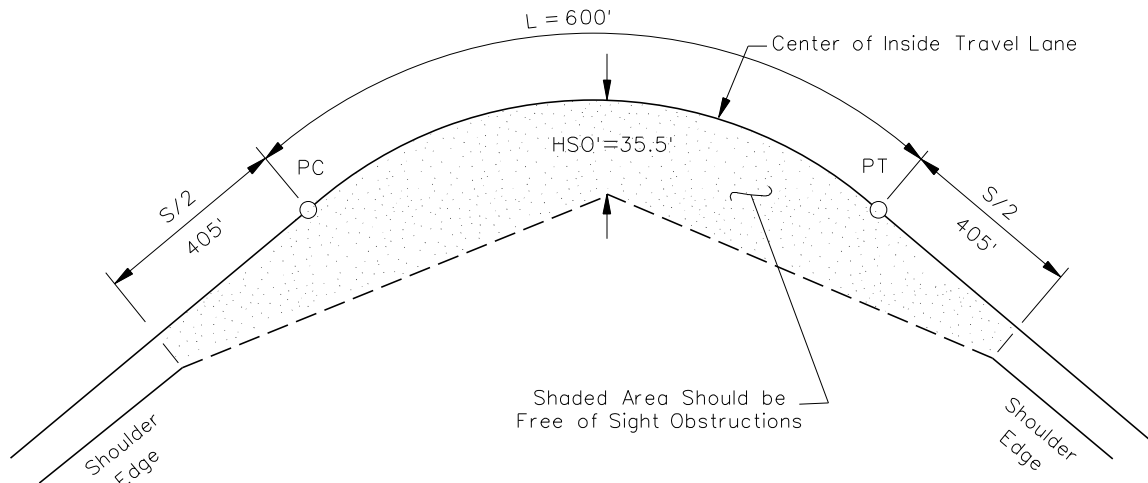

Example 32-4.2

Given: Design Speed = 70 mph
 $R = 2050$ ft
 $L = 600$ ft
 Grade = 5.0% downgrade

Problem: Determine the horizontal sightline offset requirements for the horizontal curve on a two-lane highway assuming passenger car SSD.

Solution: Because the downgrade is greater than 3.0%, the curve should desirably be designed for passenger cars adjusted for grade. Figure 31-3.C yields a SSD of 810 ft for 70 mph and a 5.0% downgrade. Therefore, $L < S$ (600 ft) < 810 ft, and the horizontal clearance is calculated from Equation 32-4.2 as follows:

$$\text{HSO} (L > S) = 2050 \left[1 - \cos \frac{(28.65)(810)}{2050} \right] = 39.88 \text{ ft}$$

$$\text{HSO}' (L < S) = \frac{1.2(600)(39.88)}{810}$$

$$\text{HSO}' = 35.5 \text{ ft}$$

Therefore, a minimum clearance of 35.5 ft should be provided at a distance of $L/2 = 300$ ft beyond the PC. The obstruction-free triangle around the horizontal curve would be defined by HSO' (35.5 ft) at $L/2$ and by points at the shoulder edge at $S/2 = 405$ ft before the PC and beyond the PT.

SIGHT CLEARANCE REQUIREMENTS FOR HORIZONTAL CURVES ($L < S$)

Figure 32-4.C

Each barrier location adjacent to a horizontal curve will require an individual analysis to determine its impacts on the line of sight. The designer must determine the elevation of the driver eye (3.5 ft (1080 mm) above the pavement surface), the elevation of the object (2 ft (600 mm)) above the pavement surface, and the elevation of the barrier where the line of sight intercepts the barrier run. If the barrier does block the line of sight to a 2 ft (600 mm) object, the designer should consider relocating the barrier or revising the horizontal alignment. If the barrier blocks the sight line needed for SSD on the mainline, it will be necessary to obtain a design exception.

32-4.06 Compound Curves

When a compound curve exists or is proposed on mainline highway, the designer should check sight distance across the inside of the curve graphically or, for a more accurate determination, the designer can use the Department's approved software program for cross sections and earthwork. Once detailed cross sections are finalized using the software package, the designer can also request 3D plots of the alignments to determine the view of the roadway ahead, which can then be reviewed for available sight distance.

32-5 DESIGN CONTROLS

As discussed elsewhere in Chapter 32, the design of horizontal alignment involves, to a large extent, complying with specific limiting criteria. These include minimum radii, superelevation rates, and sight distance around curves. In addition, the designer should adhere to certain design principles and controls that will determine the overall safety of the facility and will enhance the aesthetic appearance of the highway. These design principles include:

1. Consistency. Alignment should be consistent. Avoid sharp curves at the ends of long tangents and sudden changes from gentle to sharply curving alignment.
2. Directional. Alignment should be as directional as practical and consistent with physical and economic constraints. On divided highways, a flowing line that conforms generally to the natural contours is preferable to one with long tangents that slash through the terrain. Directional alignment will be achieved by using the smallest practical central angles.
3. Use of Minimum Radii. Avoid the use of minimum radii, if practical, especially in level terrain.
4. High Fills. Avoid sharp curves on long, high fills. Under these conditions, it is difficult for drivers to perceive the extent of horizontal curvature.
5. Alignment Reversals. Avoid abrupt reversals in alignment (reverse curves). Provide a sufficient tangent distance between the curves to ensure proper superelevation transitions for both curves and to allow time for the motorist to perceive the next decision point.
6. Broken-Back Curvature. Avoid where possible. This arrangement is not aesthetically pleasing, violates driver expectancy, and creates undesirable superelevation development requirements.
7. Compound Curves. Do not use compound curves on the highway mainline.
8. Coordination with Natural/Man-Made Features. The horizontal alignment should be properly coordinated with the existing alignment at the ends of new projects, natural topography, available right-of-way, utilities, roadside development, and natural/man-made drainage patterns.
9. Environmental Impacts. Horizontal alignment should be properly coordinated to minimize environmental impacts (e.g., encroachment onto wetlands).
10. Intersections. Horizontal alignment through intersections may present special problems (e.g., intersection sight distance, superelevation development crossover crowns). See Chapter 36 for the design of intersections.
11. Coordination with Vertical Alignment. Chapter 33 discusses general design principles for the coordination between horizontal and vertical alignment.

12. Bridges. Horizontal alignment must be coordinated with the location of bridges. The need for curvature and superelevation development should be evaluated for each bridge location. Crossing angles between the mainline and other features must also be considered. See Chapter 39 for additional information on horizontal alignment at bridges.

32-6 MATHEMATICAL DETAILS FOR HORIZONTAL CURVES

This Section presents mathematical details used by IDOT for various applications to the design of horizontal curves. The chart below summarizes the figures in Section 32-6. For ease of solving any horizontal alignment problems, the designer should refer to the Department's approved software program. The part of the program entitled "Coordinate Geometry" provides the necessary tools to solve most alignment problems.

Figure Number	Figure Title
Figure 32-6.A	Basic Trigonometric Formulas (Right Triangle Solution)
Figure 32-6.B	Basic Trigonometric Formulas (Oblique Triangle Solution)
Figure 32-6.C	Simple Curve Elements
Figure 32-6.D	Curve Symbols, Abbreviations and Formulas
Figure 32-6.E	Simple Curves (Geometric Principles)
Figure 32-6.F	Simple Curves (Various Elements)
Figure 32-6.G	Simple Curve Computation (Example)
Figure 32-6.H	Simple Curves (Stationing)
Figure 32-6.I	Curve Computation (Different Radius, Tangent Offset & Parallel)
Figure 32-6.J	Curve Computation (Compute PC & PT, Joining Parallel Tangent Offsets)
Figure 32-6.K	Curve Computation (Between Two Fixed Curves)
Figure 32-6.L	Curve Computation (Between a Fixed Curve and Fixed Tangent)
Figure 32-6.M	Curve (Establish a Tangent Between Two Curves)
Figure 32-6.N	Curve Introduction
Figure 32-6.O	Curve Introduction
Figure 32-6.P	Alignment (Common Point of Tangency for Two Curves)
Figure 32-6.Q	Common Point of Tangency for Two Curves (Sample Problem)
Figure 32-6.R	POC Computation Using Right Triangles
Figure 32-6.S	POC Computation Using Right Triangles (Sample Problem)
Figure 32-6.T	POC Computation Using Right Triangles
Figure 32-6.U	POC Computation Using Right Triangles (Sample Problem)
Figure 32-6.V	POC Computation Using Oblique Triangle
Figure 32-6.W	POC Computation Using Oblique Triangle (Sample Problem)
Figure 32-6.X	POC of Line 90° to Curve Tangent
Figure 32-6.Y	Reverse Curves to Parallel Tangents
Figure 32-6.Z	Reverse Curves to Parallel Tangents (Sample Problem)
Figure 32-6.AA	Reverse Curves (Tangents Not Parallel)
Figure 32-6.BB	Reverse Curves (Between Parallel Curves)
Figure 32-6.CC	Reverse Curves (Parallel Tangents with Tangent Segment Between)
Figure 32-6.DD	Curve Between Fixed Tangent and Fixed Curve (Case I)
Figure 32-6.EE	Curve Between Fixed Tangent and Fixed Curve (Case I) (Sample Problem)
Figure 32-6.FF	Curve Between Fixed Tangent and Fixed Curve (Case II)
Figure 32-6.GG	Curve Between Fixed Tangent and Fixed Curve (Case III)
Figure 32-6.HH	Curve Between Fixed Tangent and Fixed Curve (Case IV)
Figure 32-6.II	Curve Between Fixed Tangent and Fixed Curve (Case V)

MATHEMATIC DETAILS FOR HORIZONTAL CURVES**Table 32-6.A**

Figure Number	Figure Title
Figure 32-6.JJ	Three Curves Tangent to Each Other
Figure 32-6.KK	Intersection of Two Curves
Figure 32-6.LL	Simple Curve with Spirals
Figure 32-6.MM	Spiral Curve Nomenclature
Figure 32-6.NN	Spiral Curve Formulas
Figure 32-6.OO	Three-Centered Compound Curve
Figure 32-6.PP	Two-Centered Compound Curve

MATHEMATIC DETAILS FOR HORIZONTAL CURVES**Table 32-6.A**

(Continued)

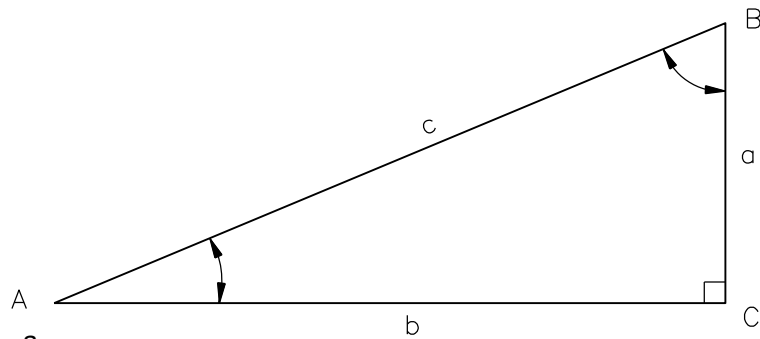

1. $\sin A = \frac{a}{c}$
2. $\cos A = \frac{b}{c}$
3. $\tan A = \frac{a}{b}$
4. $\csc A = \frac{1}{\sin A} = \frac{c}{a}$
5. $\sec A = \frac{1}{\cos A} = \frac{c}{b}$
6. $\cot A = \frac{1}{\tan A} = \frac{b}{a}$
7. $a^2 + b^2 = c^2$
8. $\text{Area} = \frac{1}{2} ab$
9. $A + B = 90^\circ$

**BASIC TRIGONOMETRIC FORMULAS
(Right Triangle Solution)**

Figure 32-6.A

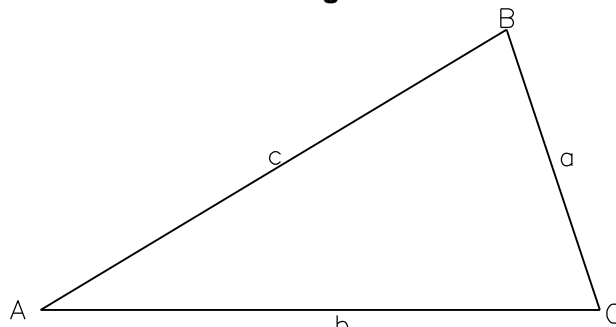

1. $a = \frac{c \sin A}{\sin C}$
2. $b = \frac{a \sin B}{\sin A}$
3. $c = \frac{a \sin C}{\sin A}$
4. $\tan A = \frac{a \sin C}{b - a \cos C}$
5. $\tan B = \frac{b \sin C}{a - b \cos C}$
6. $a^2 = b^2 + c^2 - 2bc \cos A$
7. $b^2 = a^2 + c^2 - 2ac \cos B$
8. $c^2 = a^2 + b^2 - 2ab \cos C$
9. $\cos A = \frac{b^2 + c^2 - a^2}{2bc}$
10. $\cos B = \frac{a^2 + c^2 - b^2}{2ac}$
11. $\cos C = \frac{a^2 + b^2 - c^2}{2ab}$
12. $\text{Area} = \sqrt{s(s-a)(s-b)(s-c)}$
where: $s = \frac{1}{2}(a + b + c)$

**BASIC TRIGONOMETRIC FORMULAS
(Oblique Triangle Solution)**

Figure 32-6.B

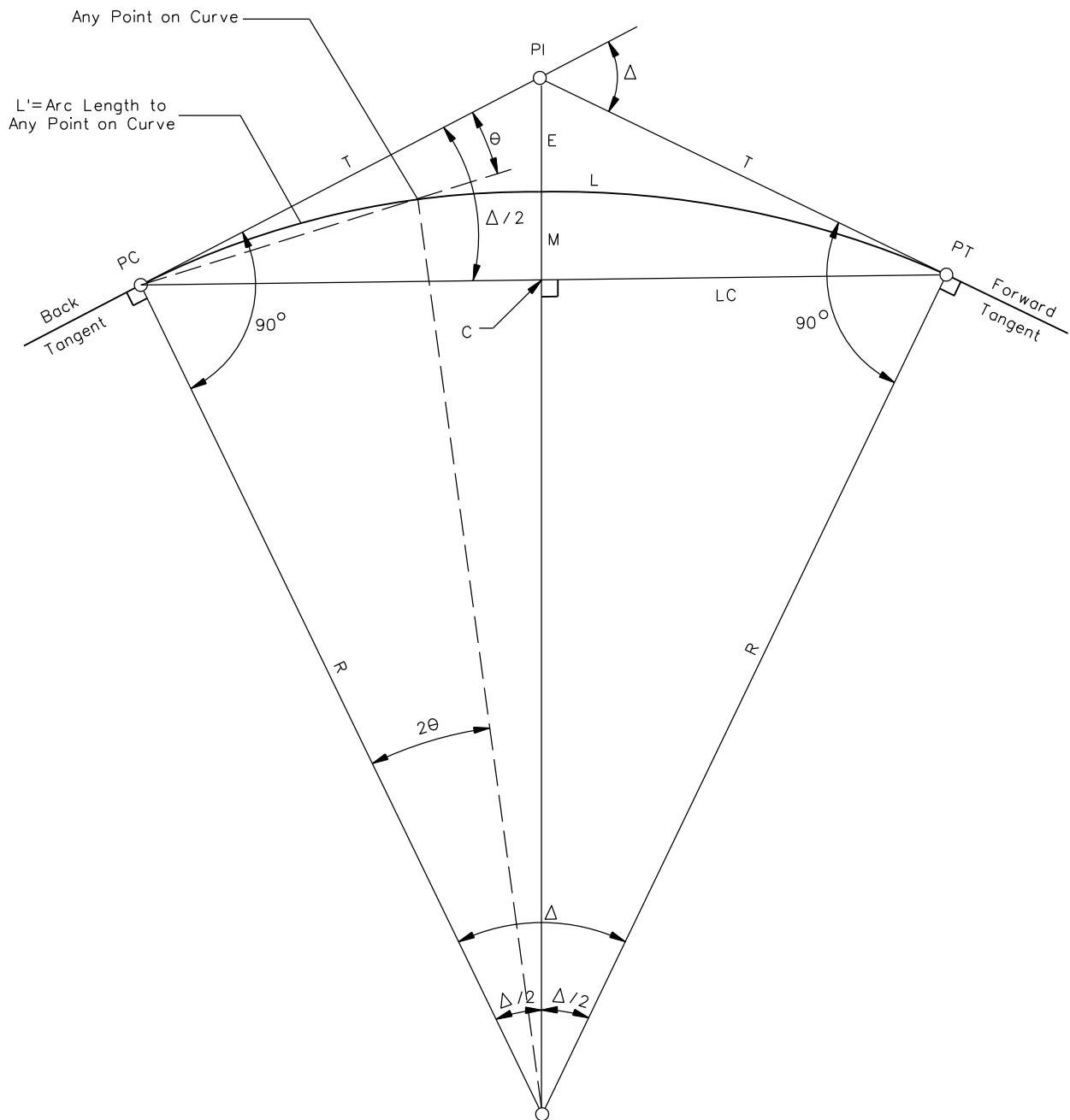

Note: See Figure 32-6.D for definition of terms.

SIMPLE CURVE ELEMENTS

Figure 32-6.C

CURVE SYMBOLS

- Δ = Deflection angle between tangents or central angle, degrees
 T = Tangent distance = distance from PC to PI = distance from PI to PT
 L = Length of curve = distance from PC to PT along curve
 R = Radius of curve, ft (m)
 E = External distance (PI to mid-point of curve)
 LC = Length of long chord: PC to PT
 M = Middle ordinate (mid-point of arc to mid-point of long chord)
 C = Mid-point of long chord

CURVE FORMULA

$$T = R(\tan (\Delta / 2)) = R \frac{\sin (\Delta / 2)}{\cos (\Delta / 2)}$$

$$L = \frac{\Delta}{360} 2\pi R = \frac{\Delta R}{57.2958}, \text{ where } \Delta \text{ is in degrees (decimals) to four places.}$$

$$E = T \tan (\Delta / 4)$$

$$E = R \left(\frac{1}{\cos (\Delta / 2)} - 1 \right)$$

$$LC = 2R (\sin (\Delta / 2)) = 2T (\cos (\Delta / 2))$$

$$M = R (1 - \cos (\Delta / 2))$$

$$M = E \cos (\Delta / 2)$$

$$\pi = 3.141592653$$

CIRCULAR CURVE ABBREVIATIONS

- P.C. = PC = Point of Curvature
 (Beginning of Curve)
 P.T. = PT = Point of Tangency (End of Curve)
 P.I. = PI = Point of Intersection of Tangents
 P.R.C. = PRC = Point of Reverse Curvature
 P.C.C. = PCC = Point of Compound Curvature
 P.O.T. = POT = Point on Tangent

To find the deflection angle θ , in degrees, to any point on the curve (see Figure 32-6.C):

$$\frac{2\theta}{L'} = \frac{360^\circ}{2\pi R}, \text{ where } L' \text{ is any arc length}$$

To find the deflection angle θ in minutes to any point:

$$\theta = \frac{(360^\circ) \left(\frac{60 \text{ min.}}{\text{deg}} \right) (L')}{(2)(2\pi R)}$$

$$\theta = \frac{21,600 L'}{4\pi R}$$

$$\theta = \frac{1718.873 L'}{R}$$

CURVE SYMBOLS, ABBREVIATIONS, AND FORMULAS**Figure 32-6.D**

The radius of a circular curve drawn to the tangent point is perpendicular to the tangent at that point.

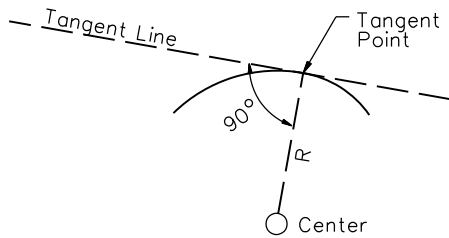

The figure below forms an isosceles triangle. Therefore, Angle O = Angle D. Also $B + D + O = 180^\circ$ (sum of the interior angles of a triangle). Also, $\Delta + B = 180^\circ$ (angle around a point forming a straight line). Therefore, $\Delta = O + D$ and, having shown that $O = D$, then $\Delta = O + O = (2) (O)$ or $O = (\Delta/2)$.

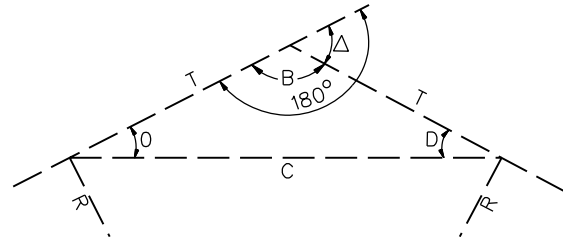

From any point on a circular curve, the angle intercepting a given arc on the same circular curve is equal to 1/2 the central angle (Δ) for that particular arc.

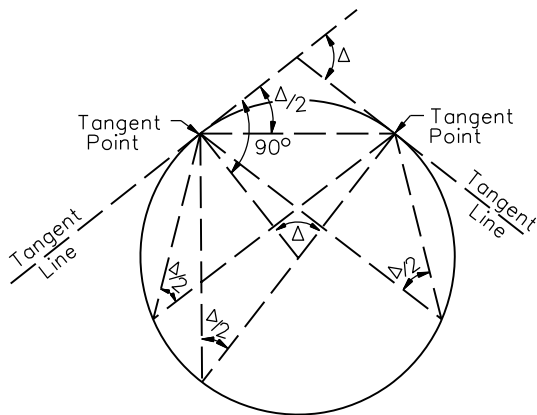

The figure below shows the 2 tangents and 2 radii of a simple curve. $A + \Delta = 180^\circ$. Also, $A + 90^\circ + 90^\circ + C = 360^\circ$ (sum of the interior angles in a 4-sided figure) or $A + C = 180^\circ$. Therefore, $\Delta = C$. C is also called the central angle but is usually designated by Δ .

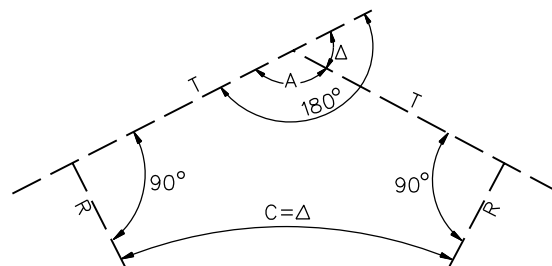

**SIMPLE CURVES
(Geometric Principles)**

Figure 32-6.E

Δ = DEFLECTION ANGLE

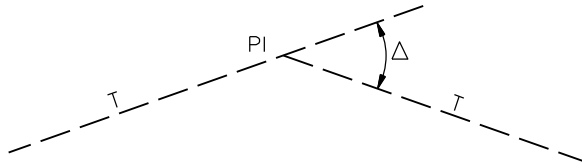

Δ = The deflection angle from the first tangent extended to the second tangent. This is the same angle as the angle between radii (central angle). This should be known before the other parts of the curve are computed.

L = LENGTH OF CURVE

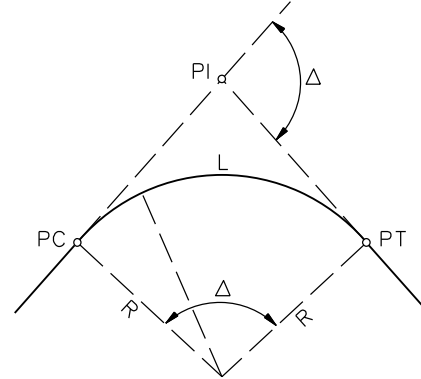

With a constant Δ, L increases or decreases in direct ratio to R. Thus:

$$L = \frac{\Delta}{360} (2\pi R)$$

Reducing to: $L = \Delta R / 57.2958$

Where L and R are in feet (meters) and Δ is in degrees (decimals) to four places.

R = RADIUS

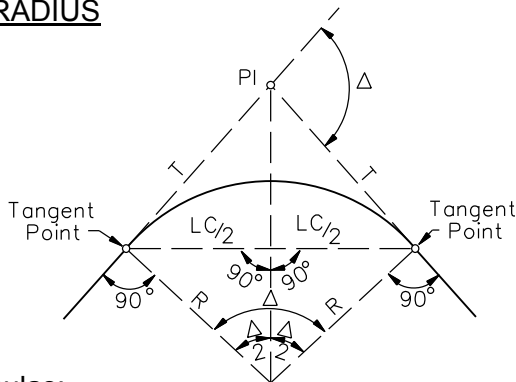

Formulas:

$$R = \frac{T}{\tan (\Delta / 2)}$$

OR

$$R = \frac{LC}{2 \sin (\Delta / 2)}$$

Where R is in feet (meters) and Δ is in degrees (decimals).

T = TANGENT LENGTH

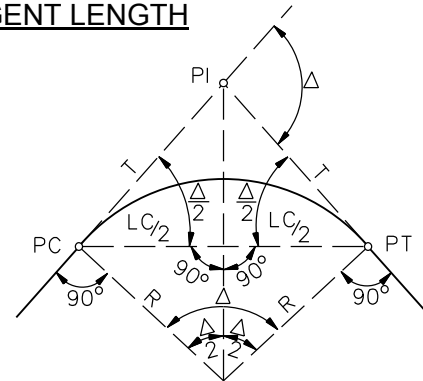

Formulas:

$$T = R \tan (\Delta / 2)$$

$$T = \frac{LC}{2 \cos (\Delta / 2)}$$

Where T, LC, & R are in feet (meters).

**SIMPLE CURVES
(Various Elements)**

Figure 32-6.F

M = MIDDLE ORDINATE

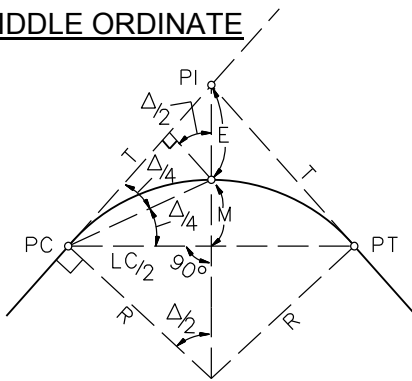

Where M, LC, R, and E are in feet (meters).

Formulas:

$$M = \frac{LC}{2} \tan (\Delta / 4)$$

$$M = E \cos (\Delta / 2)$$

$$M = R (1 - \cos (\Delta / 2))$$

LC = LONG CHORD

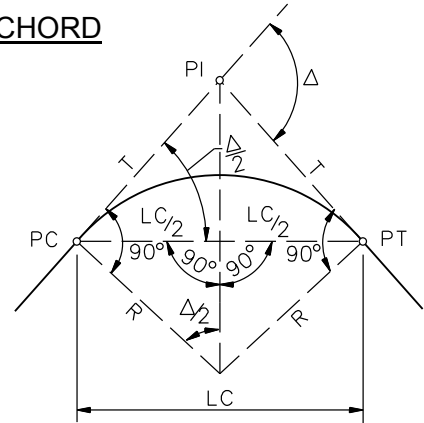

Formulas:

$$LC = 2R \sin (\Delta / 2)$$

$$LC = 2T \cos (\Delta / 2)$$

The main chord and short chords are often convenient to use in laying out the curve.

Figure can be applied to the whole chord or to the chord of any part of the curve. Δ would then be the central angle of the arc of whatever part of the curve is being considered.

E = EXTERNAL DISTANCE

Formulas: $E = R \left(\frac{1}{\cos (\Delta / 2)} - 1 \right)$

Also: $E = \frac{M}{\cos (\Delta / 2)}$

$$E = T \tan (\Delta / 4)$$

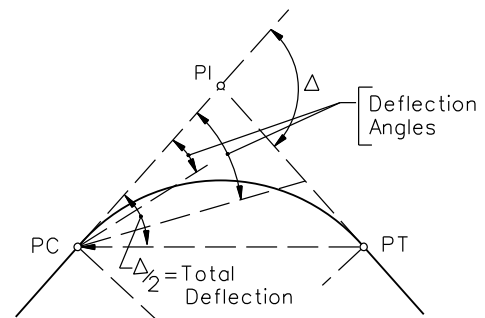

DEFLECTION ANGLES

In circular curves for highways, the deflection angle to a point on a curve is usually turned from the tangent with a set-up on the PC (see figure above).

**SIMPLE CURVES
(Various Elements)**

**Figure 32-6F
(Continued)**

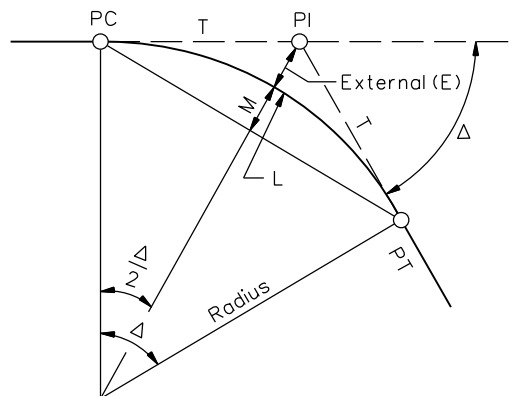
Example:

Given:

PI = Sta 161 + 60.36; $\Delta = 62^\circ 10'$; $R = 700$ ft

To find: Sta. of PC and PT:

Calculate:

$$1. \quad T = R \tan (\Delta / 2) = (700) \tan (31^\circ 05')$$

$$T = 421.99 \text{ ft}$$

$$2. \quad L = \Delta R / 57.2958 = 759.51 \text{ ft}$$

3. Therefore:

$$\begin{array}{rcl} \text{PI} & = & \text{Sta. } 161 + 60.36 \\ \text{T} & = & \underline{\quad - 421.99 \quad} \\ \text{PC} & = & \text{Sta.} \\ \text{L} & = & \underline{\quad + 759.51 \quad} \\ \text{PT} & = & \text{Sta. } 164 + 97.88 \end{array}$$

**SIMPLE CURVE COMPUTATION
(Example)**

Figure 32-6.G

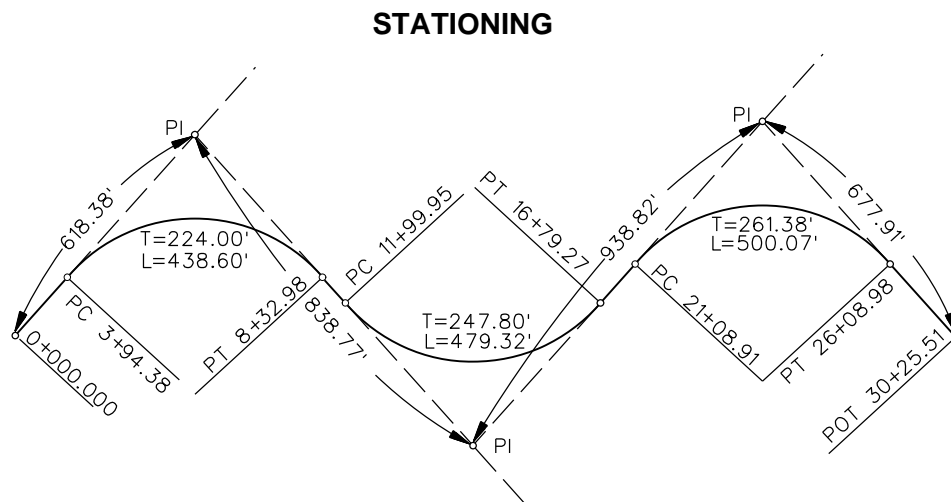

Note: All dimensions in feet.

1. The station at the first PI is 6 + 18.38.
2. The station at the first PC = 6 + 18.38 – 224.00 = 3 + 94.38.
3. The station at the first PT = 3 + 94.38 + 438.60 = 8 + 32.98.
4. The station at the second PC = 8 + 32.98 + (838.77 – 224.00 – 247.80) = 11+ 99.95.
5. The station at the second PI = 11 + 99.95 + 247.80 = 14 + 47.75.
6. The station at the second PT = 11 + 99.95 + 479.32 = 16 + 79.27.
7. The station at the third PC = 16 + 79.27 + (938.82 – 247.80 – 261.38) = 21 + 08.91.
8. The station at the third PI = 21 + 08.91 + 261.38 = 23 + 70.29.
9. The station at the third PT = 21 + 08.91 + 500.07 = 26 + 08.98.
10. The station at the final POT = 26 + 08.98 + (677.91 – 261.38) = 30 + 25.51.
11. Check: (618.38 + 838.77 + 938.82 + 677.91) – (2 (224.00) + 2 (247.80) + 2 (261.38) – 438.60 – 479.32 – 500.07) = 30 + 25.51.

**SIMPLE CURVE
(Stationing)**

Figure 32-6.H

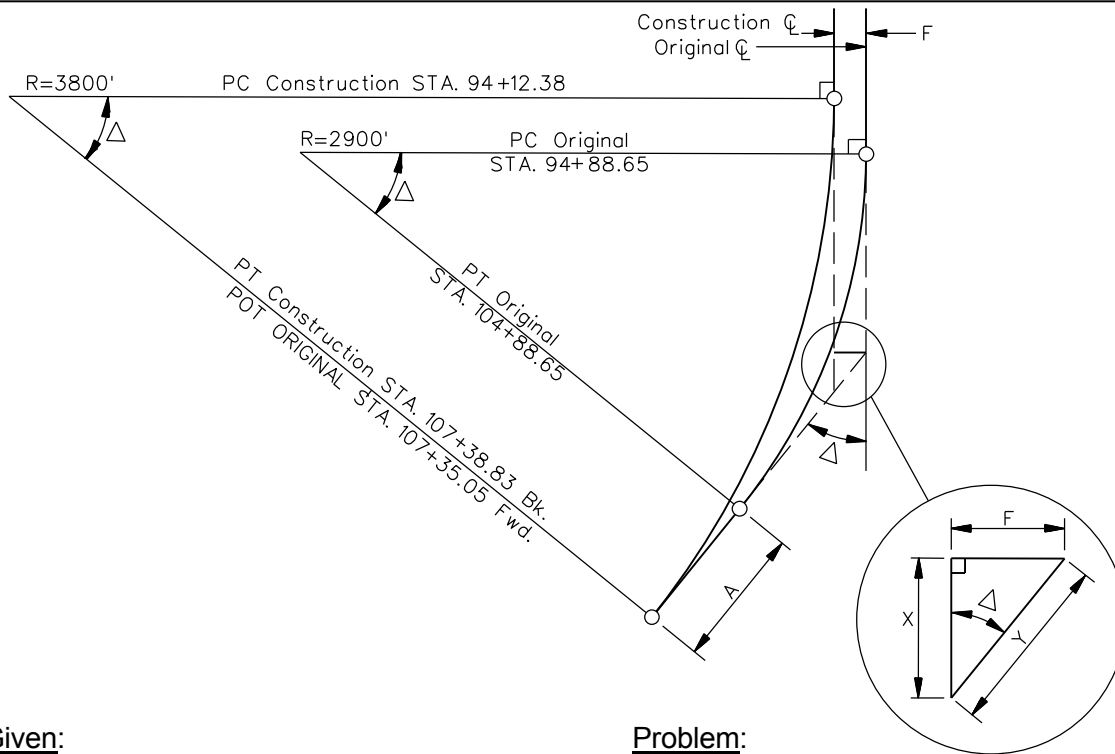

Given:

Simple Curve

- Original PI = 100 + 00.00
- $\Delta = 20^{\circ}00'$ Rt.
- T = 511.35 ft
- L = 1000 ft
- R = 2900 ft

Problem:

Compute: Simple curve of different radius where one tangent is offset a specified distance from and parallel to the original tangent.

R = 3800 ft, F = 30 ft Rt.

Solution:

- $Y = F/\sin \Delta = 30/\sin 20^{\circ} = 87.71$ ft
- $X = F/\tan \Delta = 30/\tan 20^{\circ} = 82.42$ ft
- $T = (R)\tan (\Delta/2) = (3800) (\tan 10^{\circ}) = 670.04$ ft
- $L = \Delta 2\pi R / 360 = 1326.45$ ft

CONSTRUCTION CURVE DATA

- PI = 100 + 82.42
- $\Delta = 20^{\circ}00'$ Rt.
- T = 670.04 ft
- L = 1326.45 ft
- R = 3800 ft

STATIONING

Orig. PI = 100 + 00.0	Const. T = 670.04
+X = 82.42	+Y = 87.71
Const. PI = 100 + 82.42	757.75
-T = -670.04	-Orig. T = -511.35
Const. PC = 94 + 12.38	A = 246.40
+L = +1326.45	Orig. PT = 104 + 88.65
Const. PT = 107 + 38.83	Orig. POT = 107 + 35.05

Equation: Const. PT 107 + 38.83 Bk = Orig. POT 107 + 35.05 Fwd

**CURVE COMPUTATION
(Different Radius, Tangent Offset & Parallel)**

Figure 32-6.I

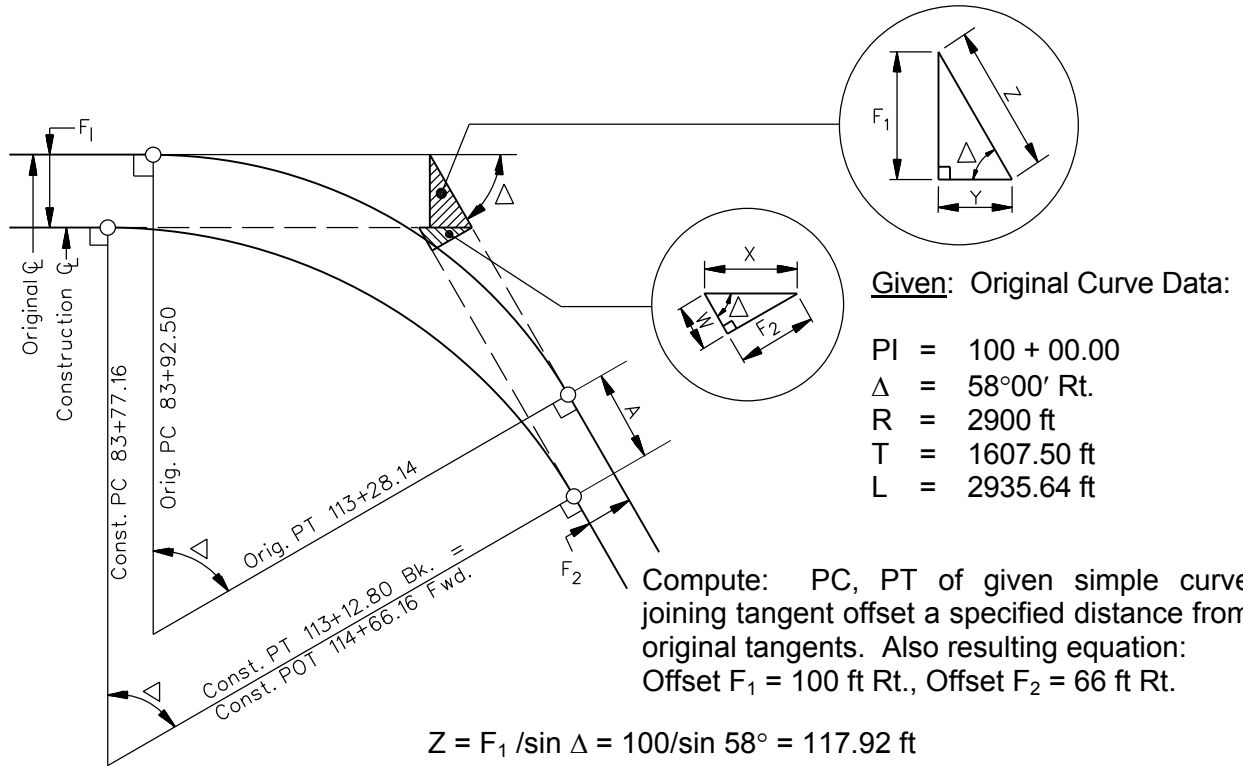

Compute: PC, PT of given simple curve joining tangent offset a specified distance from original tangents. Also resulting equation: Offset $F_1 = 100$ ft Rt., Offset $F_2 = 66$ ft Rt.

$$Z = F_1 / \sin \Delta = 100 / \sin 58^\circ = 117.92 \text{ ft}$$

$$Y = F_1 / \tan \Delta = 100 / \tan 58^\circ = 62.49 \text{ ft}$$

$$X = F_2 / \sin \Delta = 66 / \sin 58^\circ = 77.83 \text{ ft}$$

$$W = F_2 / \tan \Delta = 66 / \tan 58^\circ = 41.24 \text{ ft}$$

$$\text{Const. PI} = \text{Orig. PI} + Y - X = 99 + 84.66$$

Note: In many cases, $Y > X$ & $W > Z$ or offsets may be to other side of original tangents causing the problem to look different, but the principles of the problem remain the same.

Const. PI	=	99 + 84.66	
-T	=	<u>- 1607.50</u>	
Const. PC	=	83 + 77.16	
+L	=	<u>+ 2935.64</u>	
Const. PT	=	113 + 12.80	
A = Z - W =	=	<u>+ 76.68</u>	
Orig. PT	=	113 + 89.48	
+A	=	<u>+ 76.68</u>	
		114 + 66.16	(Orig. POT 66 ft Lt. of PT 114 + 66.16)

Equation: Const. PT 113 + 12.80 Bk = Sta. 114 + 66.16 Fwd

CURVE COMPUTATION
(Compute PC & PT, Joining Parallel Tangent Offsets)

Figure 32-6.J

INTRODUCE A CURVE OF SELECTED RADIUS BETWEEN TWO FIXED CURVES

Part A: Fixed curves of equal radii.

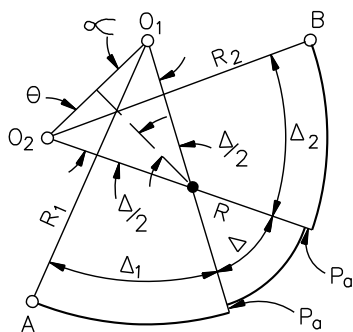

Given:

R₁ and R₂ = Radii of fixed curves with radials AO₁ and BO₂ fixed on coordinate system.

R = Radius selected for intermediate curve.

P_a, P_{a1} and P_{a2} = Offset (“p” distance) to permit insertion of selected spirals; without spirals, P_a = 0.

Problem:

To determine Δ, Δ₁ and Δ₂ and the remaining properties of each curve.

Solution:

Determine length and bearing of O₁O₂ from given coordinates of O₁ and O₂:

$$\Delta = 2 \sin^{-1} \frac{O_1O_2}{2(R_1 - R - P_a)^*}$$

$$\alpha = \theta = 90^\circ - \frac{\Delta}{2}$$

Determine bearing O₁O by applying α to bearing O₁O₂.

Determine bearing O₂O by applying θ to bearing O₁O₂.

Δ₁ = difference in bearings of O₁O and O₁A.

Δ₂ = difference in bearings of O₂O and O₂B.

Determine remaining properties of each curve through usual procedures.

* Where R is greater than R₁ and/or R₂:

$$\Delta = 2 \sin^{-1} \frac{O_1O_2}{2(R - R_1 - P_a)}$$

**CURVE COMPUTATION
(Between Two Fixed Curves)**

Figure 32-6.K

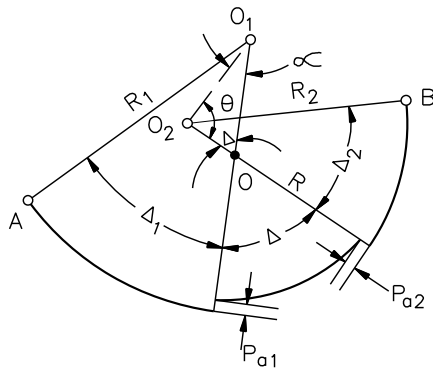
Part B: Fixed curves of unequal radii.**Given:**

R_1 and R_2 = Radii of fixed curves with radials AO_1 and BO_2 fixed on coordinate system.

R = Radius selected for intermediate curve.

P_a , P_{a1} and P_{a2} = Offset ("p" distance) to permit insertion of selected spirals; without spirals, $P_a = 0$.

Problem:

To determine Δ , Δ_1 and Δ_2 and the remaining properties of each curve.

Solution:

Determine length and bearing of O_1O_2 from given coordinates of O_1 and O_2 .

$$OO_1 = R_1 - (R + P_{a1})^*$$

$$OO_2 = R_2 - (R + P_{a2})^*$$

$$\Delta = \cos^{-1} \frac{OO_1^2 + OO_2^2 - O_1O_2^2}{2 \times OO_1 \times OO_2}$$

$$\alpha = \cos^{-1} \frac{OO_1^2 + OO_2^2 - O_1O_2^2}{2 \times OO_1 \times O_1O_2}$$

$$\theta = 180^\circ - (\Delta + \alpha)$$

Determine bearing O_1O by applying α to bearing O_1O_2 .

Determine bearing O_2O by applying θ to bearing O_1O_2 .

Δ_1 = difference in bearings of O_1O and O_1A .
 Δ_2 = difference in bearings of O_2O and O_2B .

Determine remaining properties of each curve through usual procedures.

* Where R is greater than R_1 and/or R_2 :

$$OO_1 = R - (R_1 + P_{a1})$$

$$OO_2 = R - (R_2 + P_{a2})$$

**CURVE COMPUTATION
(Between Two Fixed Curves)**

**Figure 32-6.K
(Continued)**

ESTABLISH A TANGENT BETWEEN TWO CURVES

Part A: Curves in reverse direction.

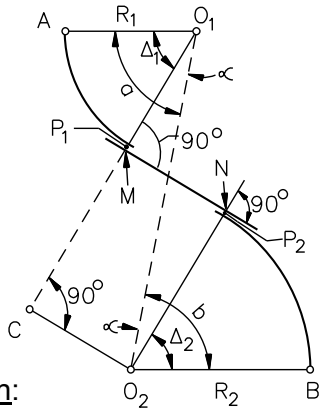

Given:

R_1 & R_2 = Radii of fixed curves with coordinates of radials AO_1 & BO_2 .

P_1 & P_2 = Offset (“p” distance) to permit insertion of selected spirals; without spirals, P_1 and $P_2 = 0$.

Problem:

To determine length and bearing of tangent MN , Δ_1 , Δ_2 and the remaining properties of each curve.

Solution:

Determine length and bearing of O_1O_2 from known coordinates; then, in triangle O_1O_2C :

$$\alpha = \cos^{-1} \frac{(R_1 + P_1)^* + (R_2 + P_2)^*}{O_1O_2}$$

$$CO_2 = MN = [(R_1 + P_1)^* + (R_2 + P_2)^*] \tan \alpha$$

Determine angles a and b from bearings of O_1A , O_2B and O_2O_1 :

$$\Delta_1 = a - \alpha; \quad \Delta_2 = b - \alpha$$

Determine remaining properties of each curve through usual procedures.

Part B: Curves in same direction.

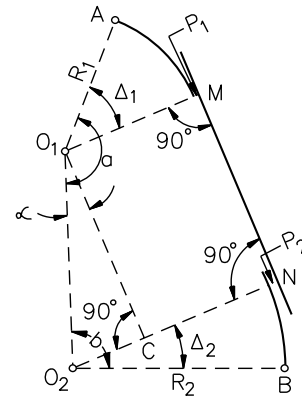

Given:

R_1 & R_2 = Radii of fixed curves with coordinated radials AO_1 & BO_2 .

P_1 & P_2 = Offset (“p” distance) to permit insertion of selected spirals; without spirals, P_1 and $P_2 = 0$.

Problem:

To determine length and bearing of tangent MN , Δ_1 , Δ_2 and the remaining properties of each curve.

Solution:

Determine length and bearing of O_1O_2 from known coordinates; then, in triangle O_1O_2C :

$$\alpha = \sin^{-1} \frac{(R_2 + P_2)^* - (R_1 + P_1)^*}{O_1O_2}$$

$$O_1C = MN = [(R_2 + P_2)^* - (R_1 + P_1)^*] / \tan \alpha$$

Determine angles a and b from bearings of O_1A , O_2B and O_2O_1 :

$$\Delta_1 = a - 90^\circ - \alpha; \quad \Delta_2 = b - 90^\circ + \alpha$$

Determine remaining properties of each curve through usual procedures.

* P_1 and $P_2 = 0$ when spirals are not used.

**CURVE
(Establish a Tangent Between Two Curves)**

Figure 32-6.M

INTRODUCE A CURVE AND TO DETERMINE ITS RADIUS BETWEEN A GIVEN POINT ON A FIXED TANGENT AND SOME POINT ON A FIXED CURVE

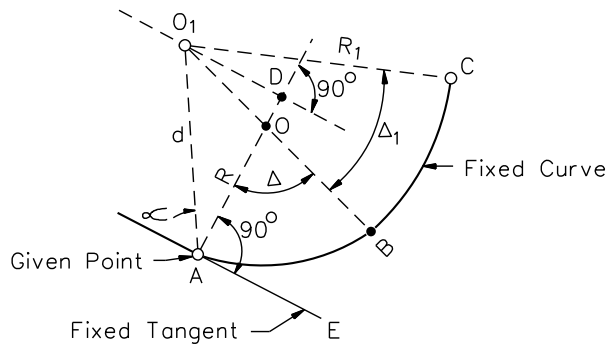

$$R = \frac{d^2 - R_1^2}{2(d \cos \alpha - R_1)}$$

and

$$\Delta = \sin^{-1} \frac{d \sin \alpha}{R_1 - R}$$

Determine bearing BO_1 by application of Δ to bearing AD_1 , then $\Delta_1 =$ difference in bearings of BO_1 and CO_1 .

Note: This solution is applicable whether $R < \text{or} > R_1$.

Given:

R_1 and coordinates of O_1 and C. Tangent AE, its bearing, and coordinates of A.

Problem:

To determine R, Δ , and Δ_1 .

Solution:

Erect right triangles AO_1D and O_1OD . Determine length and bearing of AO_1 or d from known coordinates of A and O_1 . From solution of triangles AO_1D and O_1OD :

CURVE INTRODUCTION

Figure 32-6.O

Triangles Involved:

1. GHI
2. DFG
3. ABC & CDE

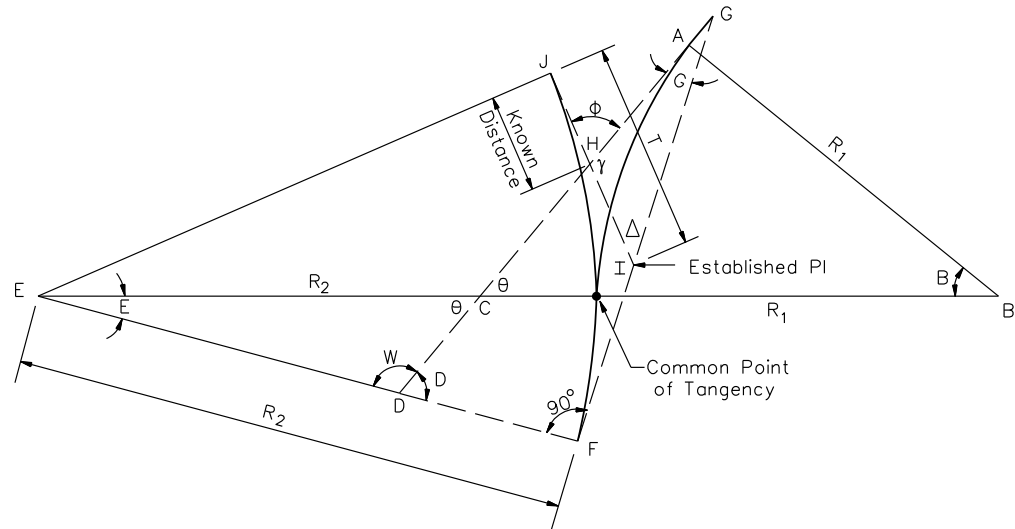

Given:

One of the curves already established (JF, Δ, T): Radii of curves (R₁ & R₂). Intersection point and angle of the two centerlines (H & φ).

Distance JH is thereby known and HI can be determined by subtracting JH from T for established curve.

Distance between curve centers (BE = R₁ + R₂).

Triangle No. 1, GHI

Find: ∠G & GI

1. $\gamma = 180^\circ - \phi$
2. $\angle G = 180^\circ - (\gamma + \Delta)$
3. $HI = T \text{ (est. curve)} - JH$
4. $GI = \frac{HI \sin \gamma}{\sin \angle G}$

Triangle No. 2, DGF

Find: ∠D & DF

5. $FG = T \text{ (est. curve)} + GI$
6. $DF = FG \tan \angle G$
7. $\angle D = 90^\circ - \angle G$

Triangles No. 3, ABC & CDE

Find: ∠θ (Angles at B & E are thus determined)

$$BC + CE = R_1 + R_2$$

In triangle ABC:

$$BC = \frac{R_1}{\sin \theta}$$

$$BC + CE = \frac{R_1}{\sin \theta} + \frac{DE \sin W}{\sin \theta} = R_1 + R_2$$

In triangle CDE:

8. $DE = R_2 - DF$
9. $W = 180^\circ - \angle D$

$$CE = \frac{DE \sin W}{\sin \theta}$$

$$10. \sin \theta = \frac{R_1 + DE \sin W}{R_1 + R_2}$$

$$11. \angle B = 90^\circ - \theta$$

$$12. \angle E = 180^\circ - (\theta + W)$$

Length of curves, tangent length, etc., are determined.

**ALIGNMENT
(Common Point Of Tangency For Two Curves)**

Figure 32-6.P

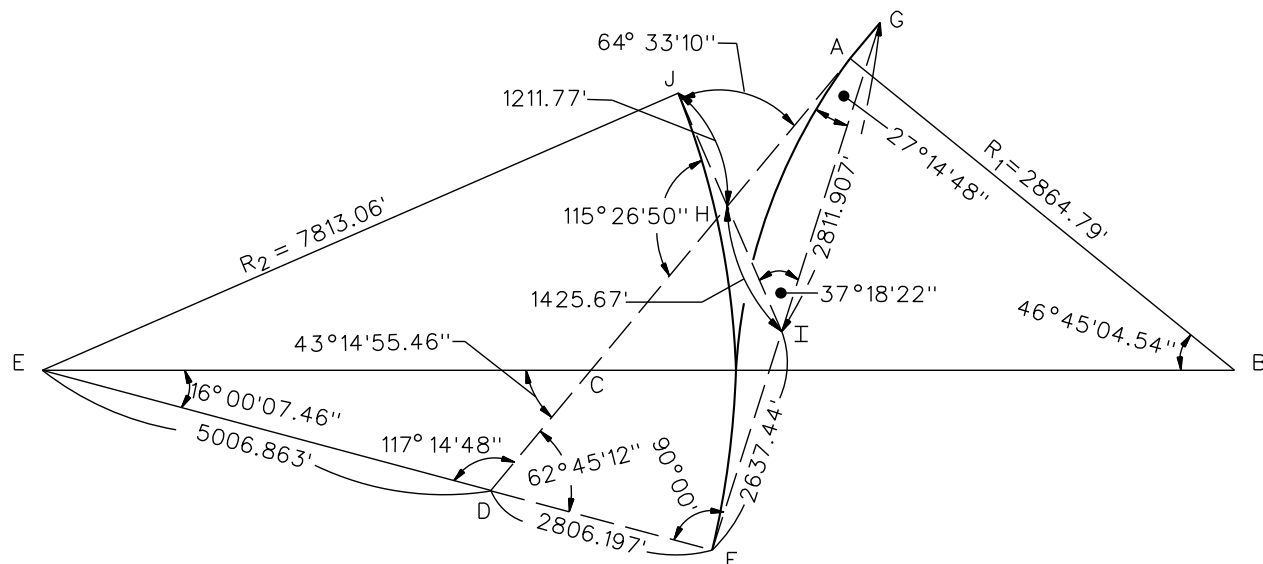
**Given:**

$$\begin{aligned}\phi &= 64^{\circ}33'10'' \\ JH &= 1211.77 \text{ ft} \\ \Delta &= 37^{\circ}18'22'' \\ T &= 2637.44 \text{ ft} \\ R_2 &= 7813.06 \text{ ft} \\ R_1 &= 2864.79 \text{ ft}\end{aligned}$$

1. $\gamma = 180^{\circ}00'00'' - 64^{\circ}33'10'' = 115^{\circ}26'50''$
2. $\angle G = 180^{\circ}00'00'' - (115^{\circ}26'50'' + 37^{\circ}18'22'') = 27^{\circ}14'48''$
3. $HI = 2637.44 - 1211.77 = 1425.67 \text{ ft}$
4. $GI = (1425.67) (0.90298146 / (0.45782219)) = 2811.907 \text{ ft}$
5. $FG = 2637.44 + 2811.907 = 5449.357 \text{ ft}$
6. $DF = (5449.347) (0.5149602) = 2806.197 \text{ ft}$
7. $\angle D = 90^{\circ}00'00'' - 27^{\circ}14'48'' = 62^{\circ}45'12''$
8. $DE = 7813.06 - 2806.197 = 5006.863 \text{ ft}$
9. $\angle W = 180^{\circ}00'00'' - 62^{\circ}45'12'' = 117^{\circ}14'48''$
10. $\sin \theta = (2864.79 + (5006.863) (0.88904378)) / (2864.79 + 7813.06) = 0.68516695$
 $\theta = 43^{\circ}14'55.46''$
11. $\angle B = 90^{\circ}00'00'' - 43^{\circ}25'55.46'' = 46^{\circ}45'04.54''$
12. $\angle E = 180^{\circ}00'00'' - (46^{\circ}45'04.54'' + 117^{\circ}14'48'') = 16^{\circ}00'07.46''$

**COMMON POINT OF TANGENCY FOR TWO CURVES
(Sample Problem)**

Figure 32-6.Q

Given:

AB, Angle A, and Curve Data

Required:

AE and Arc Dist. BE

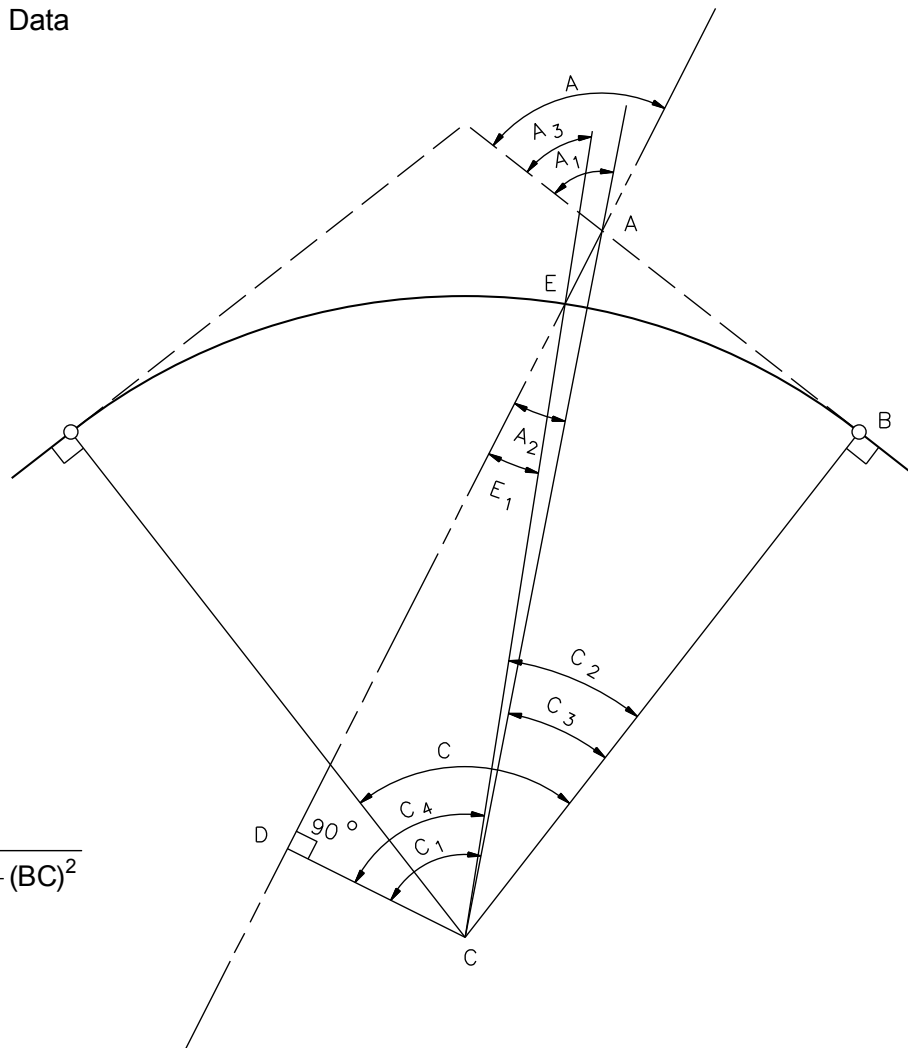
Solution:

1. $BC = \text{Radius}$
2. $AC = \sqrt{(AB)^2 + (BC)^2}$
3. $\sin C_3 = \frac{AB}{AC}$
4. $A_1 = 90^\circ - C_3$
5. $A_2 = A - A_1$
6. $CD = AC \sin A_2$
7. $AD = AC \cos A_2$
8. $EC = \text{Radius}$
9. $\sin E_1 = \frac{CD}{EC}$
10. $DE = EC \cos E_1$
11. $C_1 = 90^\circ - A_2$
12. $C_4 = 90^\circ - E_1$
13. $C_2 = C_3 + C_1 - C_4$
14. $AE = AD - DE$
15. $\text{Arc Dist. BE} = \frac{C_2}{360} 2\pi R$

POC COMPUTATION USING RIGHT TRIANGLES**Figure 32-6.T**

Given:

Angle A = $80^{\circ}07'23''$
 AB = 1732.60 ft
 Radius = 7813.06 ft

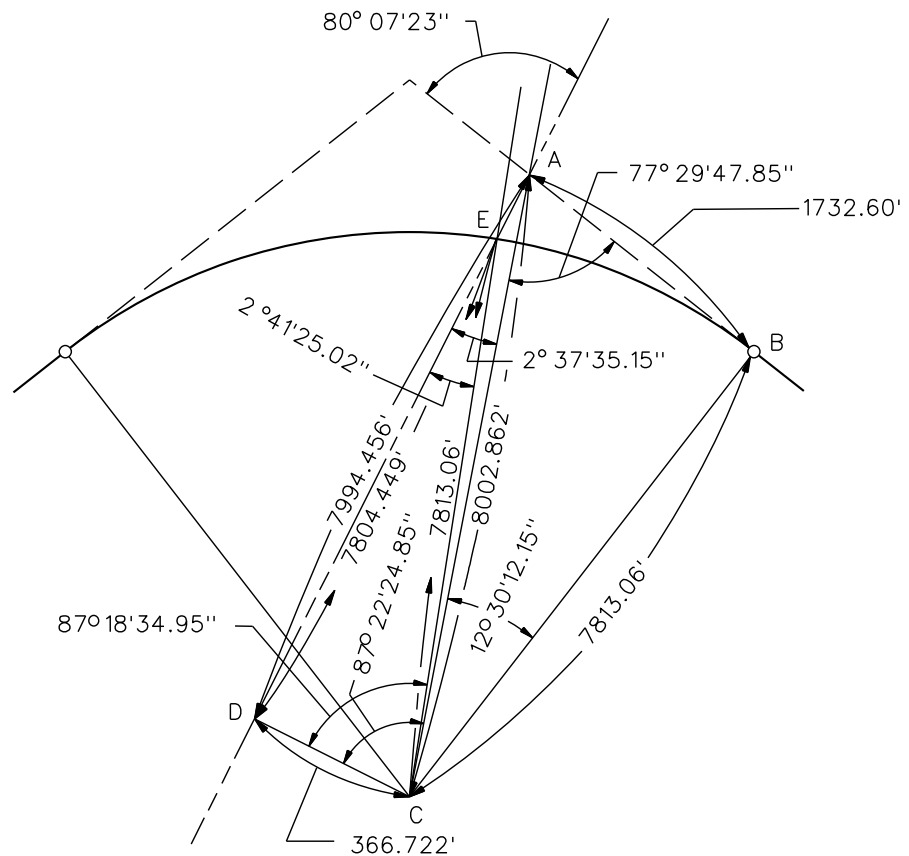

1. BC = 7813.06 ft
2. AC = $\sqrt{(1732.60)^2 + (7813.06)^2} = 8002.862$ ft
3. $\sin C_3 = 1732.60 / 8002.86 = 0.2164975$ $C_3 = 12^{\circ}30'12.15''$
4. $A_1 = 90^{\circ}00'00'' - 12^{\circ}30'12.15'' = 77^{\circ}29'47.85''$
5. $A_2 = 80^{\circ}07'23.00'' - 77^{\circ}29'47.85'' = 2^{\circ}37'35.15''$
6. CD = $(8002.862) (0.04582381) = 366.722$ ft
7. AD = $(8002.862) (0.99894954) = 7994.456$ ft
8. EC = 7813.06 ft
9. $\sin E_1 = 366.722 / 7813.06 = 0.04693705$ $E_1 = 2^{\circ}41'25.02''$
10. DE = $(7813.06) (0.99889785) = 7804.449$ ft
11. $C_1 = 90^{\circ}00'00'' - 2^{\circ}37'35.15'' = 87^{\circ}22'24.85''$
12. $C_4 = 90^{\circ}00'00'' - 2^{\circ}41'25.02'' = 87^{\circ}18'34.95''$
13. $C_2 = 12^{\circ}30'12.15'' + 87^{\circ}22'24.85'' - 87^{\circ}18'34.98'' = 12^{\circ}34'02.02''$
14. AE = $7994.456 - 7804.449 = 190.02$ ft
15. Arc BE = $(12.567228) (2\pi) (7813.06) / 360 = 1713.71$ ft

**POC COMPUTATION USING RIGHT TRIANGLES
 (Sample Problem)**

Figure 32-6.U

Given:

AB = 1732.60 ft
 Angle B = $99^{\circ}52'37''$
 Radius = 8000 ft

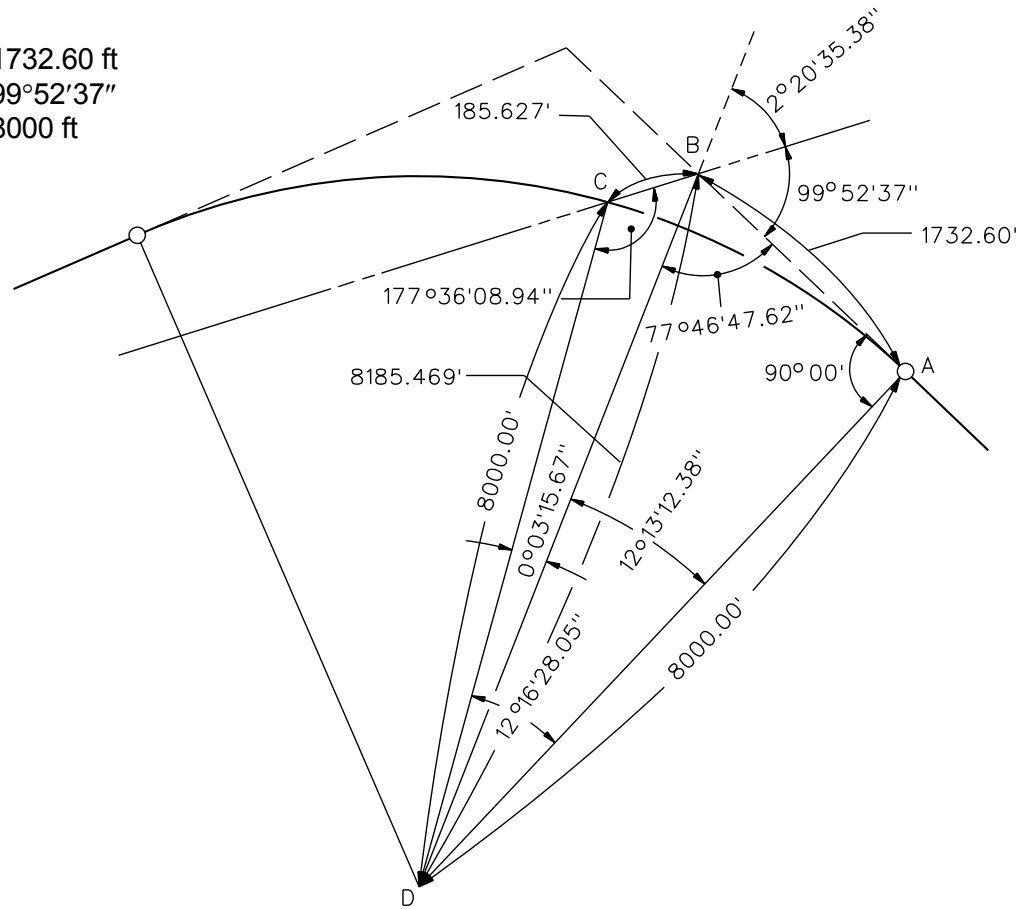
Solution:

1. AD = 8000.00 ft
2. BD = $\sqrt{(1732.60)^2 + (8000.00)^2} = 8185.469$ ft
3. $\sin D = 1732.60 / 8185.469 = 0.211667773$ $D = 12^{\circ}13'12.38''$
4. $B_1 = 90^{\circ}00' - 12^{\circ}13'12.38'' = 77^{\circ}46'47.62''$
5. $B_2 = 180^{\circ}00' - (99^{\circ}52'37'' + 77^{\circ}46'47.62'') = 2^{\circ}20'35.38''$
6. $\sin C = (8185.469) (0.04088448) / 8000.00 = 0.041832334$ $C = 177^{\circ}36'08.94''$
7. $D_1 = 180^{\circ}00' - (2^{\circ}20'35.38'' + 177^{\circ}36'08.94'') = 0^{\circ}03'15.67''$
8. BC = $(8000.00) (0.00094866) / (0.040884478) = 185.627$ ft
9. $I = 12^{\circ}13'12.38'' + 0^{\circ}03'15.67'' = 12^{\circ}16'28.05''$
10. Arc AC = $(12.2744583) (2\pi) (8000.00) / 360 = 1713.838$ ft

**POC COMPUTATION USING OBLIQUE TRIANGLE
(Sample Problem)**

Figure 32-6.W

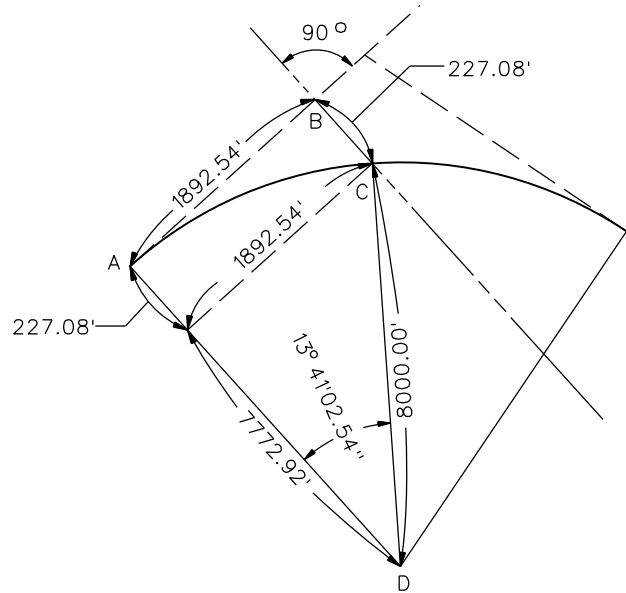
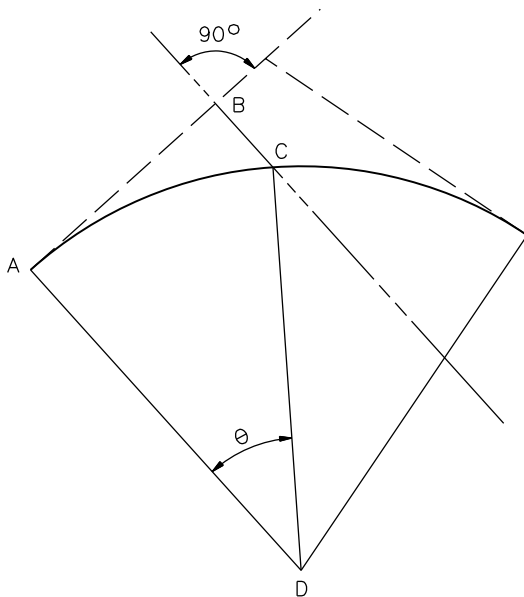

EXAMPLE

Given:

AB and Curve Data.

Required:

BC and Arc Dist. AC.

Solution:

1. CD = Radius
2. $\sin \theta = \frac{AB}{CD}$
3. $BC = CD - \sqrt{(CD)^2 - (AB)^2}$
4. $\text{Arc AC} = \frac{\theta}{360} 2\pi R$

Given:

AB = 1892.54 ft
 Radius = 8000.00 ft

Solution:

1. CD = 8000.00 ft
2. $\sin \theta = 1892.54 \text{ ft} / 8000.00 = 0.2365675$
 $\theta = 13^\circ 41' 02.54''$
3. $BC = 8000.00 - \sqrt{(8000.00)^2 - (1892.54)^2}$
 $= 227.08 \text{ ft}$
4. $\text{Arc AC} = (13.68403956) (2\pi) (8000.00) / 360$
 $= 1910.65 \text{ ft}$

POC OF LINE 90° TO CURVE TANGENT

Figure 32-6.X

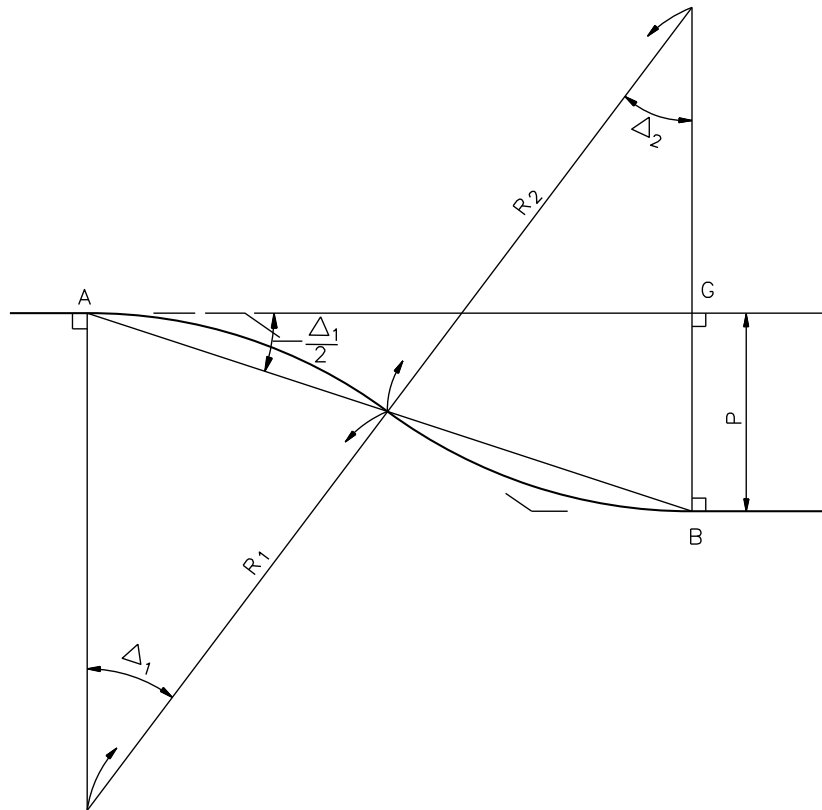
EQUAL RADIIGiven: Radius & BG

1. $R_1 = R_2$
2. $\Delta_1 = \Delta_2$
3. $BG = P$
4. $\cos \Delta_1 = \frac{R_1 - \frac{1}{2}P}{R_1}$
5. $AG = \sqrt{4PR_1 - P^2}$
6. $\sin \Delta_1 = \frac{AG}{R_1 + R_2}$
7. $\tan \Delta_1 = \frac{AG}{R_1 + R_2 - P}$

UNEQUAL RADIIGiven: R_1 , AG, & P

1. $\Delta_1 = \Delta_2$
2. $AB = \sqrt{AG^2 + P^2}$
3. $R_2 = \frac{(AB)^2}{2P} - R_1$
4. $\sin \Delta_1 = \frac{AG}{R_1 + R_2}$
5. $\cos \Delta_1 = \frac{R_1 + R_2 - P}{R_1 + R_2}$
6. $\tan \Delta_1 = \frac{AG}{R_1 + R_2 - P}$

REVERSE CURVES TO PARALLEL TANGENTS**Figure 32-6.Y**

EQUAL RADIIGiven:

$$R_1 = R_2 = 2000.00 \text{ ft}$$

$$P = 12 \text{ ft}$$

Required:Find Δ_1 and Δ_2 Solution:

- $\cos \Delta_1 = (2000 - 6) / 2000 = 0.997$
 $\Delta_1 = \Delta_2 = 4^\circ 26' 21.20''$
- $AG = \sqrt{(4)(12)(2000) - (12)^2} = 309.606 \text{ ft}$
- $\sin \Delta_1 = 309.606 / (2)(2000) = 0.07740155$
 $\Delta_1 = 4^\circ 26' 21.20''$
- $\tan \Delta_1 = 309.606 / ((2)(2000) - 12) = 0.077634403$
 $\Delta_1 = 4^\circ 26' 21.20''$

UNEQUAL RADIIGiven:

$$R_1 = 2000.00 \text{ ft}$$

$$P = 12 \text{ ft}$$

$$AG = 300 \text{ ft}$$

Required:Find Δ_1 and Δ_2 Solution:

- $AB = \sqrt{(300)^2 + (12)^2} = 300.24 \text{ ft}$
- $R_2 = (300.24)^2 / (2)(12) - 2000 = 1756.00 \text{ ft}$
- $\sin \Delta_1 = (300) / (2000.00 + 1756.00) = 0.079872204$
 $\Delta_1 = \Delta_2 = 4^\circ 34' 52.39''$
- $\cos \Delta_1 = (2000.00 + 1756.00 - 12.00) / (2000.00 + 1756.00) = 0.99680511$
 $\Delta_1 = \Delta_2 = 4^\circ 34' 52.39''$
- $\tan \Delta_1 = 300 / (2000.00 + 1756.00 - 12.00) = 0.080128205$
 $\Delta_1 = \Delta_2 = 4^\circ 34' 52.39''$

**REVERSE CURVES TO PARALLEL TANGENTS
(Sample Problem)**

Figure 32-6.Z

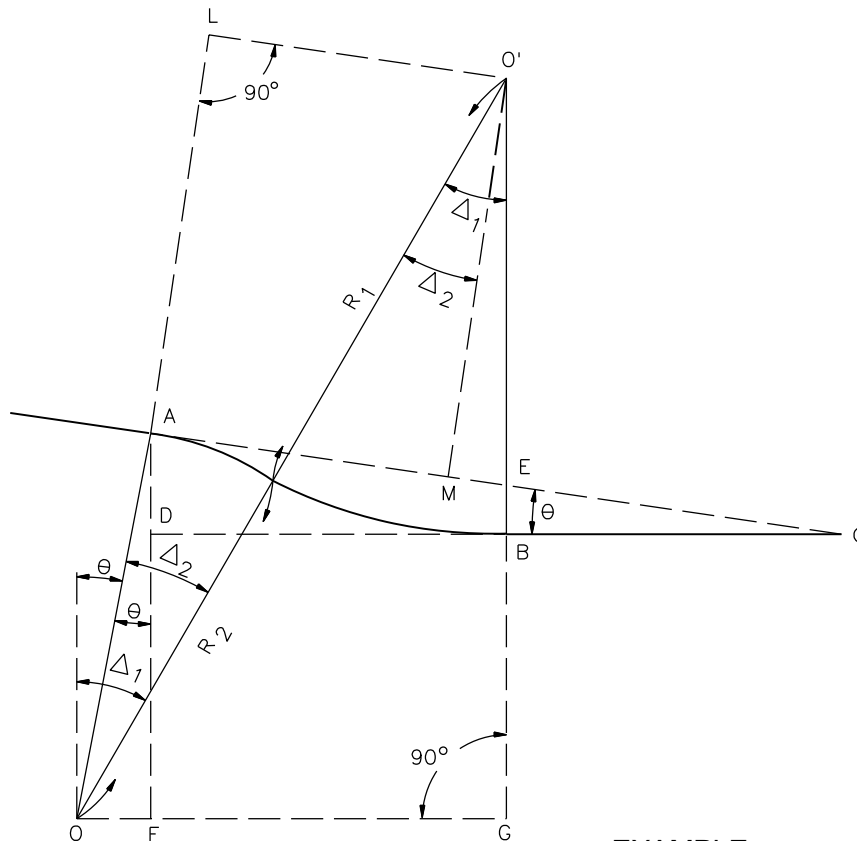

EXAMPLE

Given:

θ , AD, R_1 , and R_2

Required:

Δ_1 and Δ_2

1. $AC = \frac{AD}{\sin \theta}$
2. $BG = DF = R_2 \cos \theta - AD$
3. $\cos \Delta_1 = \frac{R_1 + BG}{R_1 + R_2}$
4. $\Delta_2 = \Delta_1 - \theta$

Given:

$\theta = 2^\circ 13' 16''$
 $AD = 54.00$ ft
 $R_1 = 17,200.00$ ft
 $R_2 = 21,500.00$ ft

Solution:

1. $AC = 54.00 / 0.038755993 = 1393.33$ ft
2. $BG = (21500.00) (0.99924874) - 54.00 = 21,429.85$ ft
3. $\cos \Delta_1 = (17,220.00 + 21,429.85) / (17,200.00 + 21,500.00) = 0.998187261$
 $\Delta_1 = 3^\circ 27' 01.48''$
4. $\Delta_2 = 3^\circ 27' 01.48'' - 2^\circ 13' 16'' = 1^\circ 13' 45.48''$

**REVERSE CURVES
(Tangents Not Parallel)**

Figure 32-6.AA

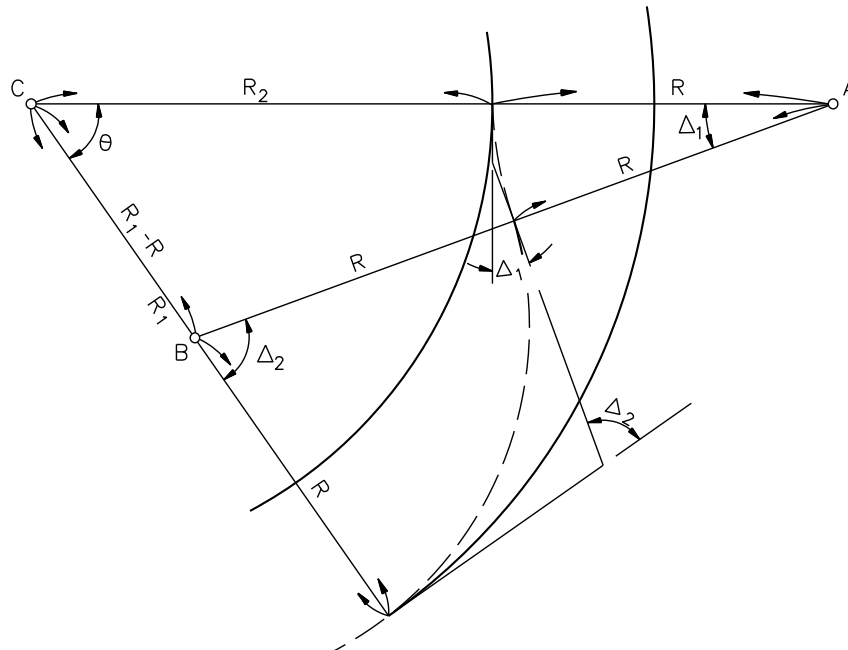
EQUATIONS:

$$1. \frac{\sin \Delta_1}{2} = \sqrt{\frac{(s-b)(s-c)}{bc}}$$

Where:

$$\begin{aligned} a &= R_1 - R \\ b &= R_2 + R \\ c &= 2R \\ s &= \frac{1}{2}(a + b + c) \end{aligned}$$

$$2. \sin \theta = \frac{2R \sin \Delta_1}{R_1 - R}$$

$$3. \Delta_2 = \Delta_1 + \theta$$

Given:

R_2 = Inside Curve Radius
 R_1 = Outside Curve Radius
 R = Equal Radii of Reverse Curve

Required:

Δ_1 & Δ_2

EXAMPLE:

$R_2 = 10,700.00$ ft, $R_1 = 10,800.00$ ft,
 $R = 2000.00$ ft

$a = 10,800.00 - 2000.00 = 8800.00$ ft
 $b = 10,700.00 + 2000.00 = 12,700.00$ ft
 $c = (2)(2000.00) = 4000.00$ ft
 $s = 12,750.00$ ft

$$1. \frac{\sin \Delta_1}{2} = \sqrt{\frac{(12,750 - 12,700)(12,750 - 4000)}{(12,700)(4000)}}$$

$$= 0.092801965$$

$$\Delta_1 = 10^\circ 41' 46.84''$$

$$2. \sin \theta = \frac{(2)(2000.00)(0.18560393)}{(10,800.00 - 2000.00)}$$

$$= 0.084365422$$

$$\theta = 4^\circ 50' 22.33''$$

$$3. \Delta_2 = 10^\circ 41' 46.84'' + 4^\circ 50' 22.33''$$

$$= 15^\circ 32' 09.17''$$

**REVERSE CURVES
 (Between Parallel Curves)**

Figure 32-6.BB

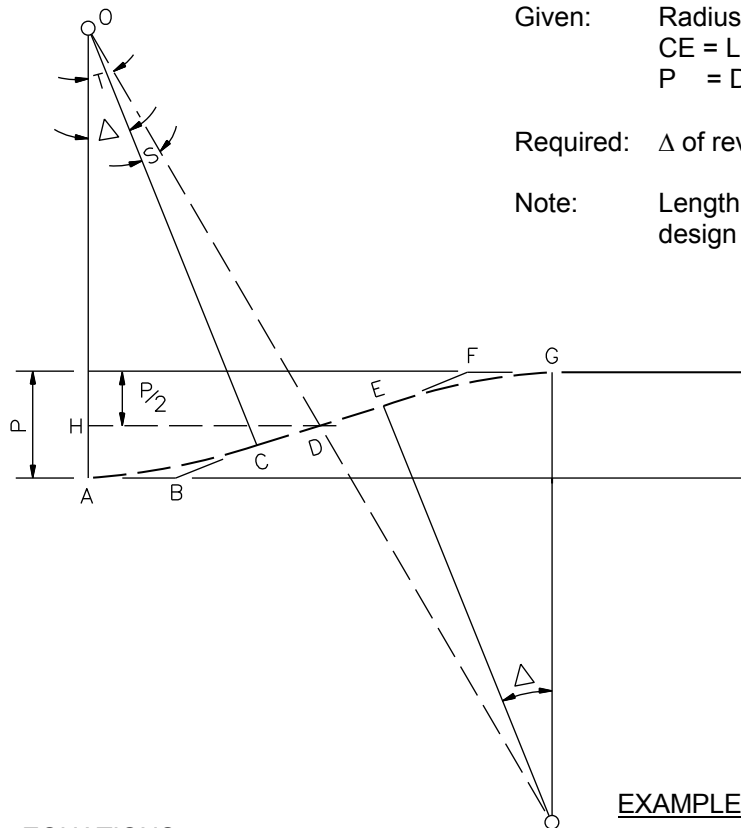

Given: Radius of Reverse Curve
 CE = Length of tangent between curves
 P = Distance between parallel tangents

Required: Δ of reverse curves

Note: Length CE is governed by superelevation runoff design criteria for each curve.

EQUATIONS:

1. $OC = OA = \text{Radius}$
2. $CD = \frac{CE}{2}$
3. $OH = OA - \frac{P}{2}$
4. $OD = \sqrt{(CD)^2 + (OC)^2}$
5. $\sin S = \frac{CD}{OD}$
6. $HD = \sqrt{(OD)^2 - (OH)^2}$
7. $\sin T = \frac{HD}{OD}$
8. $\Delta = T - S$

EXAMPLE:

Given: $R = 5800.00 \text{ ft}$
 Tangent Length = $CE = 200.00 \text{ ft}$
 $P = 130.00 \text{ ft}$

Solution:

1. $OA = 5800.00 \text{ ft}$
2. $CD = 200.00 / 2 = 100.00 \text{ ft}$
3. $OH = 5800.00 - 130.00 / 2 = 5735.00 \text{ ft}$
4. $OD = \sqrt{(100.00)^2 + (5800.00)^2}$
 $= 5800.86 \text{ ft}$
5. $\sin S = 100.00 / 5800.86 = 0.017238817$
 $S = 0^\circ 59' 15.94''$
6. $HD = \sqrt{(5800.00)^2 - (5735.00)^2} = 865.90 \text{ ft}$
7. $\sin T = 865.90 / 5800.00 = 0.149292325$
 $T = 8^\circ 37' 01.23''$
8. $\Delta = 8^\circ 35' 09.30'' - 0^\circ 59' 15.94''$
 $= 7^\circ 35' 53.37''$

REVERSE CURVES
(Parallel Tangents with Tangent Segment Between)

Figure 32-6.CC

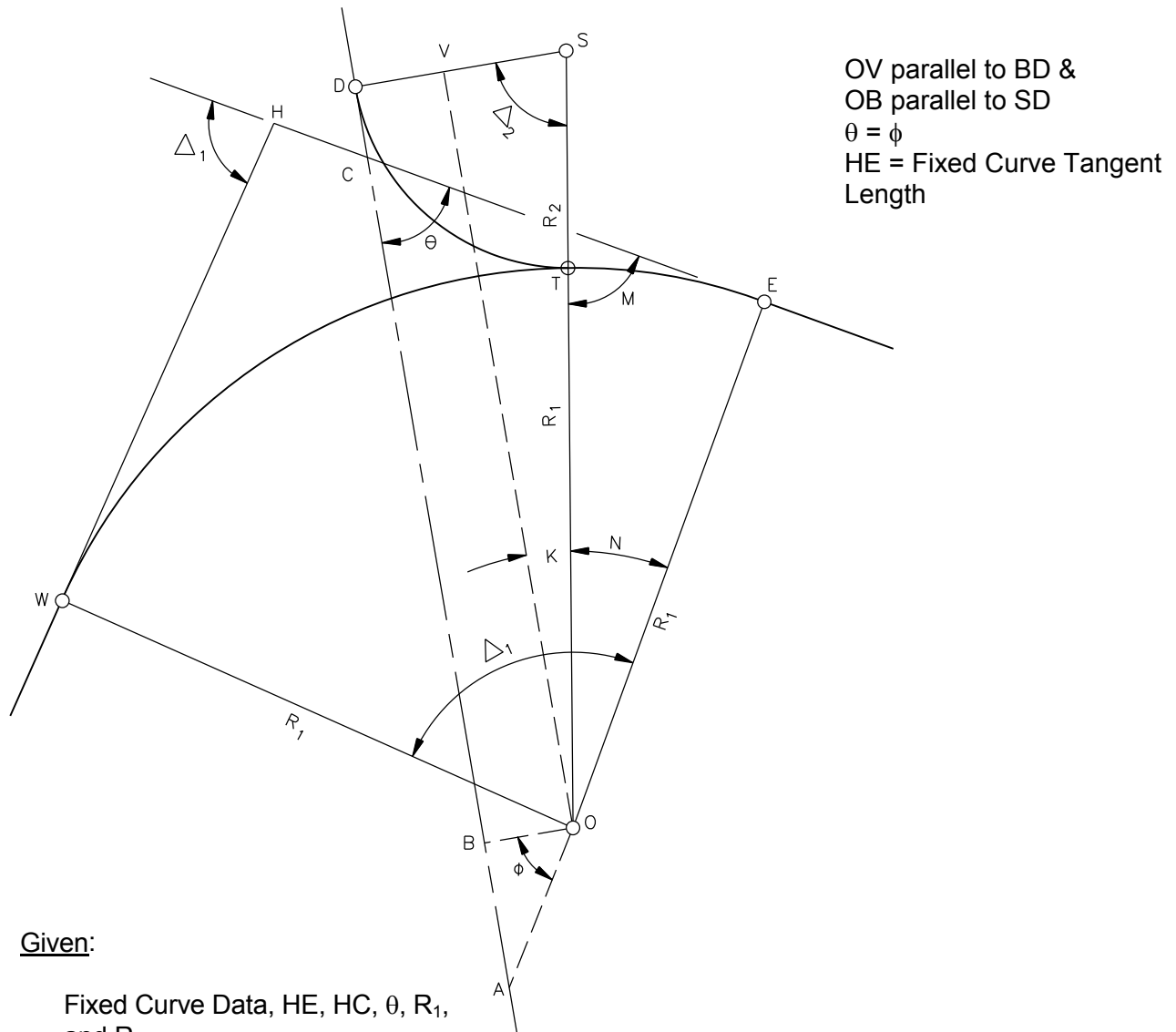

Given:

Fixed Curve Data, HE, HC, θ , R_1 , and R_2

Note:

θ must be less than 90° for this solution.
WE = fixed curve

Equations:

1. $CE = HE - HC$
2. $OA = CE \tan \theta - R_1$
3. $OB = DV = OA \cos \phi$
4. $SV = R_2 - DV$

5. $\sin K = \frac{SV}{R_1 + R_2}$
6. $\Delta_2 = 90^\circ - K$
7. $M = \theta + K$
8. $N = 90^\circ - M$
9. $\text{Arc Length ET} = \frac{N}{360} 2\pi R_1$

**CURVE BETWEEN FIXED TANGENT AND FIXED CURVE
(Case 1)**

Figure 32-6.DD

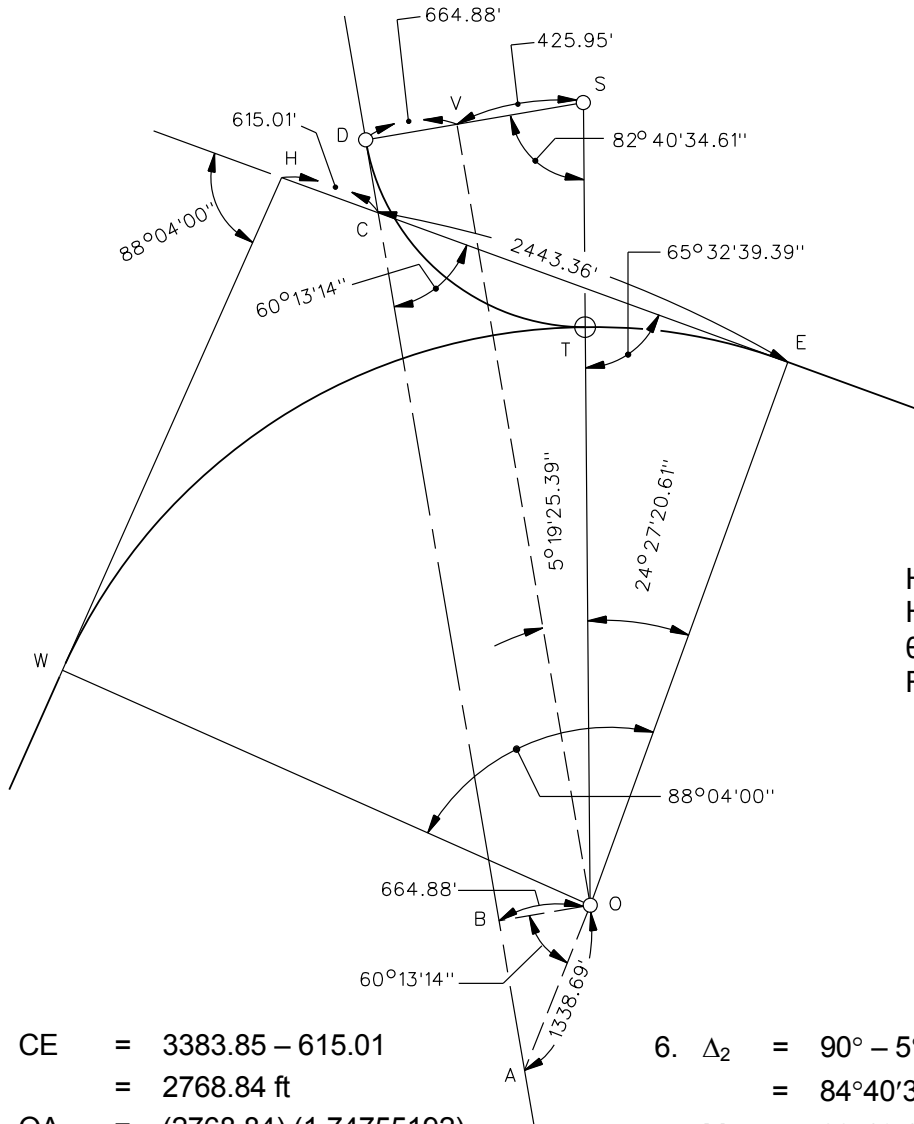

PI Sta. 116 + 82.47
 $\Delta_1 = 88^\circ 04' 00''$
 $R_1 = 3500.00$ ft
 $T = 3383.85$ ft
 $L = 5000.00$ ft

HE = 3058.37 ft
 HC = 615.01 ft
 $\theta = \phi = 60^\circ 13' 14''$
 $R_2 = 1090.83$ ft

1. CE = 3383.85 - 615.01
= 2768.84 ft
2. OA = (2768.84) (1.74755192)
- 3500.00
= 1338.69 ft
3. OB = DV = (1338.69) (0.49666261)
= 664.88 ft
4. SV = 1090.83 - 664.88 ft
= 425.95 ft
5. $\sin K = (425.95) / (3500.00 + 1090.83)$
= 0.092782786
K = $5^\circ 19' 25.39''$

6. $\Delta_2 = 90^\circ - 5^\circ 19' 25.39''$
= $84^\circ 40' 34.61''$
7. M = $60^\circ 13' 14.00'' + 5^\circ 19' 25.39''$
= $65^\circ 32' 39.39''$
8. N = $90^\circ - 65^\circ 32' 39.39''$
= $24^\circ 27' 20.61''$

Arc Length ET = $(24.45572531) (2) (\pi) (3500) / 360$
 = 1493.92 ft

CURVE BETWEEN FIXED TANGENT AND FIXED CURVE (CASE 1)
(Sample Problem)

Figure 32-6.EE

Given:

“WE” Curve Data, HC, θ , R_1 , and R_2

WE = Fixed Curve
 OF parallel to VD
 VF parallel to AD

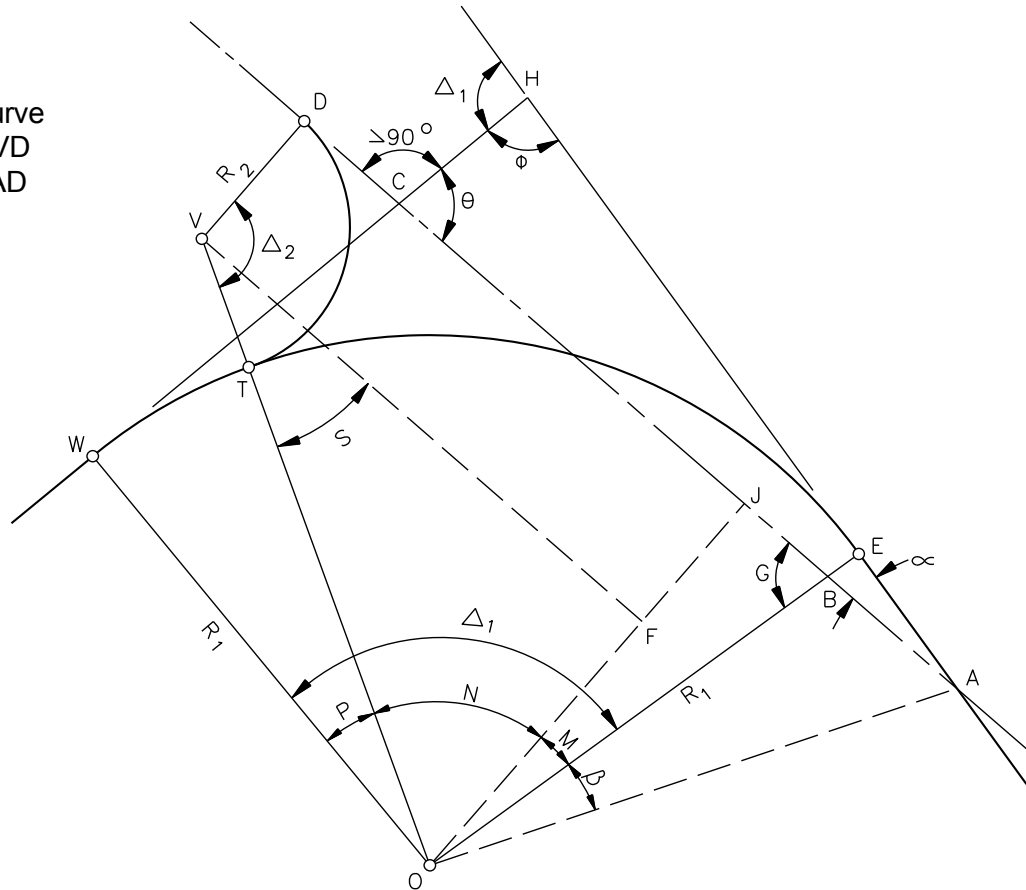

Equations:

1. $\alpha = 180^\circ - (\theta + \phi)$
2. $HA = \frac{HC \sin \theta}{\sin \alpha}$
3. $AE = HA - HE$
4. $BE = AE \tan \alpha$
5. $OB = R_1 - BE$
6. $G = 90^\circ - \alpha$
7. $OJ = OB \sin G$

8. $OF = OJ - R_2$
9. $\sin S = \frac{OF}{R_1 + R_2}$
10. $\tan \beta = \frac{AE}{R_1}$
11. $\Delta_2 = 90^\circ + S$
12. $M = 90^\circ - G$
13. $N = 90^\circ - S$
14. $P = \Delta_1 - M - N$
15. $\text{Arc Length WT} = \frac{P}{360} 2\pi R_1$

**CURVE BETWEEN FIXED TANGENT & FIXED CURVE
 (Case V)**

Figure 32-6.II

Given:

“WE” Curve Data, HC, θ , R_1 , R_2 , and R_3

Note:

θ must be less than 90°

AD = Fixed Tangent

WE = Fixed Curve

Δ_2 & N computed according to example in Case I

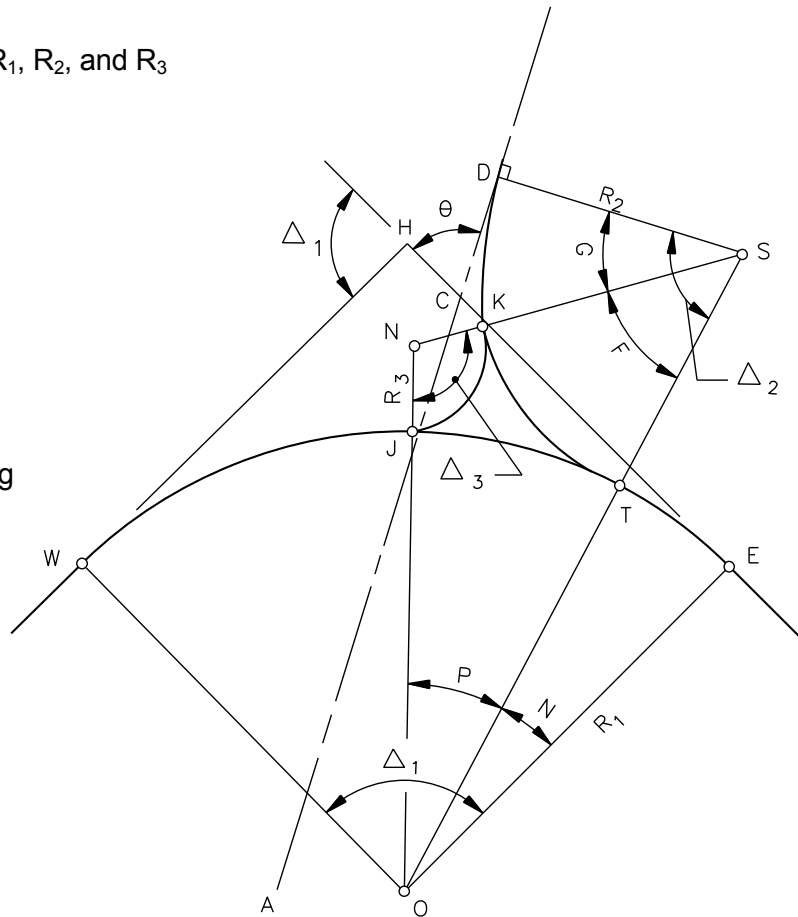

Equations:

$$1. \frac{\sin \Delta_2}{2} = \sqrt{\frac{(s-b)(s-c)}{bc}}$$

$$2. \sin P = \frac{(R_2 + R_3) \sin \Delta_2}{R_1 + R_2}$$

$$3. \sin F = \frac{(R_1 + R_3) \sin \Delta_2}{R_1 + R_2}$$

$$4. \text{Arc Length EJ} = \frac{(N + P)}{360} 2\pi R_1$$

$$5. G = \Delta_2 - F$$

$$6. \text{Arc Length DK} = \frac{G}{360} 2\pi R_2$$

$$7. \text{Arc Length KJ} = \frac{\Delta_3}{360} 2\pi R_3$$

where: $a = OS = R_1 + R_2$
 $b = NS = R_2 + R_3$
 $c = ON = R_1 + R_3$
 $s = \frac{1}{2}(a + b + c)$

THREE CURVES TANGENT TO EACH OTHER

Figure 32-6.JJ

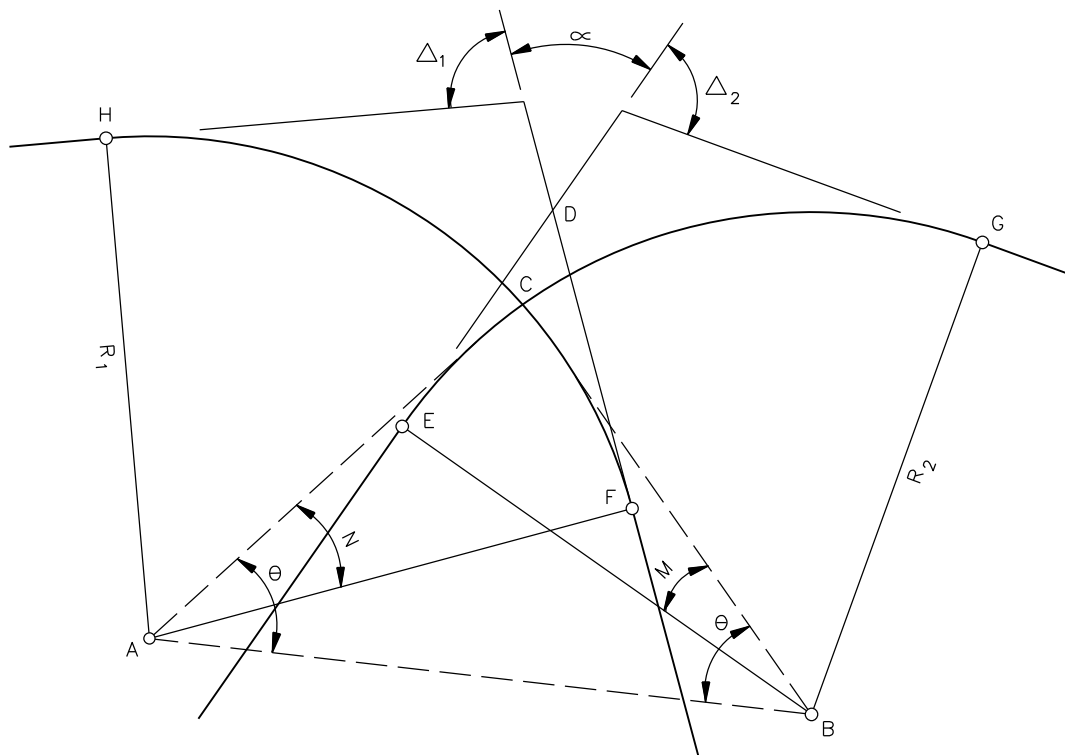

Given:

Curve data, azimuth, or bearing of curve tangents, DE, DF, & Δ .

Required:

Arc EC and Arc FC

1. Coordinates at D either given or assume grid system
2. Determine coordinates at centers of curves (A & B)
3. Determine length and bearing AB
4. $BC = R_2 = a$, $AC = R_1 = b$,
 $AB = c$

5. $s = \frac{1}{2}(a + b + c)$

6. $\frac{\sin \theta}{2} = \sqrt{\frac{(s-b)(s-c)}{bc}}$

7. $\sin \phi = \frac{R_1 \sin \theta}{R_2}$

8. Determine bearings of AC & BC

9. Determine N & M from bearings

10. $\text{Arc EC} = \frac{M}{360} 2\pi R_2$

11. $\text{Arc FC} = \frac{N}{360} 2\pi R_1$

INTERSECTION OF TWO CURVES

Figure 32-6.KK

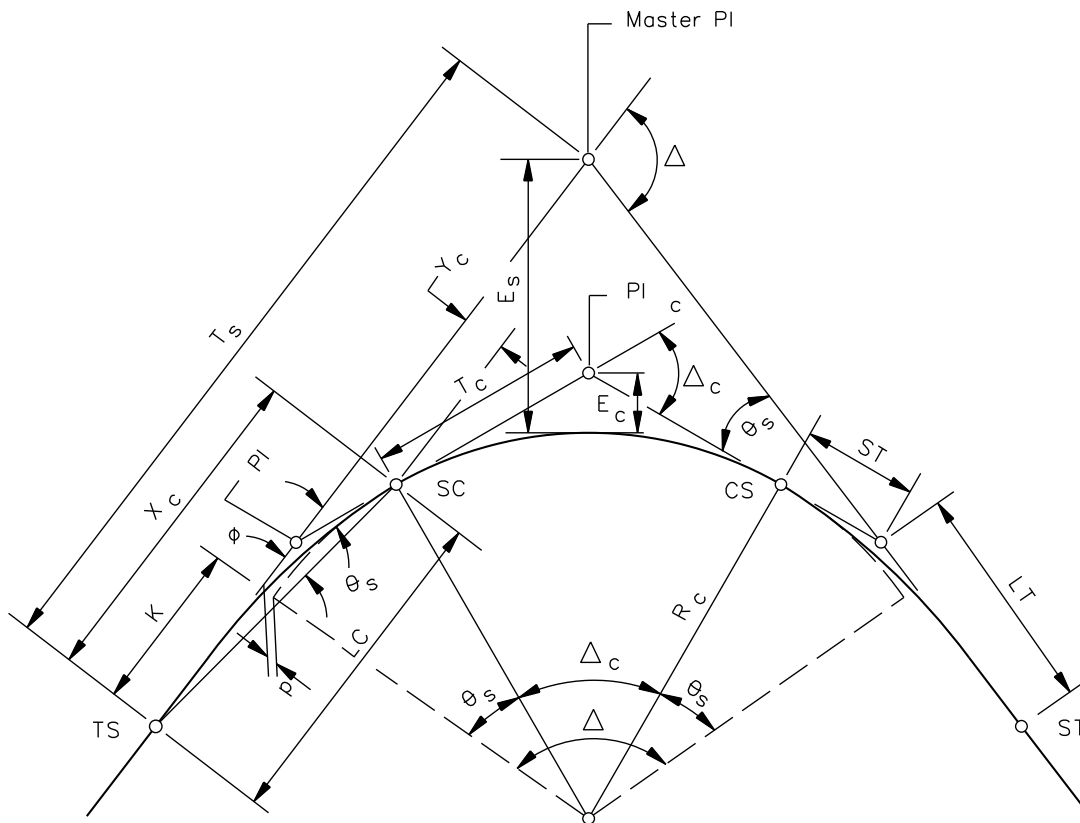

Notes:

1. All highway spirals to be computed with Department's approved software.
2. PI_c to circular curve must be set on External (E_s) and not from spiral PI (PI_s) and spiral end point (SC or CS).
3. A simple method for locating the points on a spiral transition is to divide the length of spiral into 10 or 20 equal parts, set up on the TS or SC, and locate the points by calculating deflection angles and using equal chord lengths.
4. See Figure 32-6.MM for definition of terms.

SIMPLE CURVE WITH SPIRALS

Figure 32-6.LL

SPIRAL TRANSITION CURVE NOMENCLATURE

Master PI = Point of intersection of the main tangents.	LT = Long tangent of spiral only.
PI _c = Point of intersection of circular curve tangents.	ST = Short tangent of spiral only.
PI _s = Point of intersection of the main tangent and tangent of circular curve.	LC = Long chord of spiral.
TS = Tangent to spiral, common point of spiral and near transition.	p = Offset distance from the main tangent to the PC or PT of the circular curve extended.
SC = Spiral to curve, common point of spiral and circular curve of near transition.	k = Distance from TS to point on main tangent opposite the PC of the circular curve produced.
CS = Curve to spiral, common point of circular curve and spiral of far transition.	Δ = Intersection angle between main tangents of the entire curve.
ST = Spiral to tangent, common point of spiral and tangent of far transition.	Δ _c = Intersection angle between tangents at the SC and the CS or the central angle of the circular curve.
R _c = Radius of the circular curve.	θ _s = Intersection angle between the tangent of the complete curve and the tangent at the SC, the spiral tangents intersection angle.
L _s = Length of spiral.	φ = Deflection angle from main tangent at TS to SC along the line of the long chord.
L _c = Length of circular curve.	x _c y _c = Coordinates of SC from the TS.
T _s = Tangent distance from Master PI to TS or ST, or tangent distance of completed combination of curves.	L' = Length of spiral arc from the TS to any point on the spiral.
T _c = Tangent distance from SC or CS to PI _c .	θ = The central angle of spiral arc L'. θ equals θ _s when L' equals L _s . Note: The θ referred to in Table II of <i>Transition Curves for Highways</i> is actually θ _s .
E _s = External distance from Master PI to midpoint of circular curve portion	

SPIRAL CURVE NOMENCLATURE**Figure 32-6.MM**

CURVE FUNCTIONS

1. $\theta_s = (L_s / R_c) (90/\pi)$
2. $\Delta_c = \Delta - 2\theta_s$
3. $L_c = \frac{\Delta_c}{360} 2\pi R_c$
4. $T_s = (R_c + p) \tan (\Delta/2) + k$
5. $E_s = (R_c + p) (1/\cos (\Delta/2) - 1) + p = \left[\frac{(R_c + p)}{\cos(\Delta/2)} - (R_c + p) \right] + p$

Where Δ , R_c , and L_s are givens. To find p and k , calculate θ_s and use Table II from *Transition Curves for Highways* or use tables in the Department's approved software.

SPIRAL FUNCTIONS

Corrections for C in Formula $\phi = \frac{\theta}{3} - C$								
θ_s in Degrees	15	20	25	30	35	40	45	50
C in Minutes	0.2	0.4	0.8	1.4	2.2	3.4	4.8	6.6

6. $\phi = \frac{\theta}{3}$, if $\theta_s < 15^\circ 00'$ (approx. value)
7. $\phi = \frac{\theta}{3} - C$, if $\theta_s \geq 15^\circ 00'$ (approx. value)
8. Deflection angle from TS or ST to any point "n" on spiral curve:

$$\phi = \frac{\theta_s}{3} \left[\frac{L'}{L_s} \right]^2$$
9. The exact values of ϕ can be determined by coordinates:

$$\tan \phi = \frac{y_c}{x_c}$$
10. $ST = \frac{y_c}{\sin \theta_s}$
11. $LT = x_c - \left(\frac{y_c}{\tan \theta_s} \right)$
12. $LC = \frac{x_c}{\cos \phi}$
13. $x_c = LC \cos \phi$
14. $y_c = LC \sin \phi$
15. $\theta = \frac{(L')^2}{L_s^2} \theta_s$

Note: These equations are based on *Transition Curves for Highways* by Joseph Barnett.

SPIRAL CURVE FORMULAS

Figure 32-6.NN

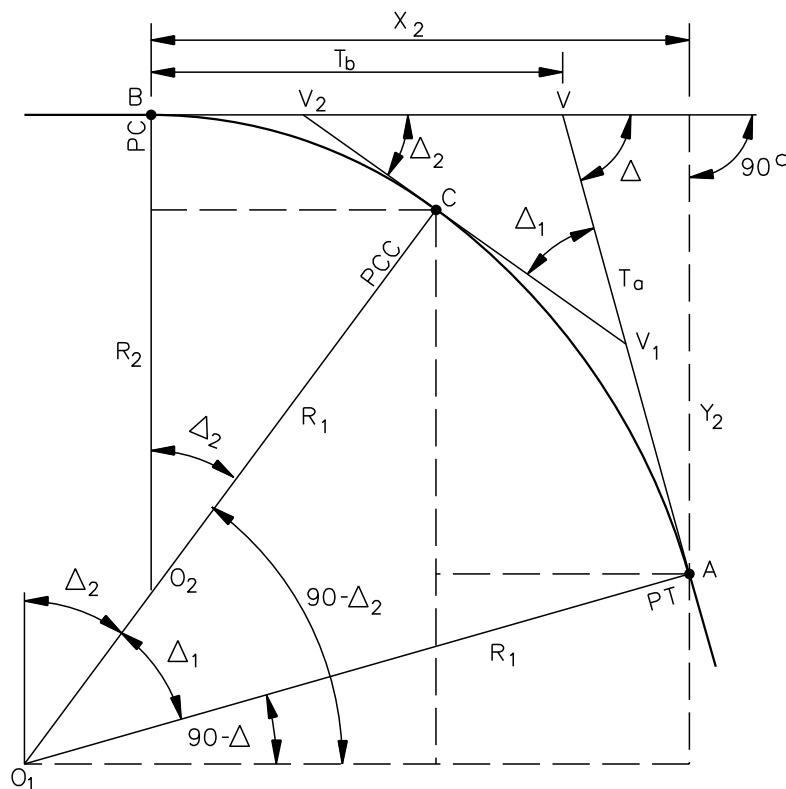

Given: R_1, R_2, Δ

Equations:

$$\Delta = \text{Total Deflection Angle} = \Delta_1 + \Delta_2$$

$$X_2 = R_1 \sin \Delta - (R_1 - R_2) \sin \Delta_2$$

$$Y_2 = R_2 - R_1 \cos \Delta + (R_1 - R_2) \cos \Delta_2$$

$$T_a = AV = Y_2 / \sin \Delta$$

$$T_b = BV = X_2 - T_a \cos \Delta$$

$$\tan(\Delta_2/2) = \frac{R_1(1 - \cos \Delta) - T_a \sin \Delta}{R_1(\sin \Delta) - T_a \cos \Delta - T_b}$$

TWO-CENTERED COMPOUND CURVE

Figure 32-6.PP

32-7 CURVE DATA

32-7.01 Rounding

The following will apply to rounding the radii of horizontal curves:

1. New Horizontal Curve. Radii will be expressed in multiples of 5 ft (1 m) increments.
2. Existing Horizontal Curve. Alignments that incorporate a previously defined horizontal curve should continue to use the same existing radius, and the radius will be re-defined to the nearest 0.01 ft (0.001 m). For example, a 3-degree curve which is a re-creation of a previously established curve will be assigned a 1909.86 ft (582.125 m) radius.

* * * * *

Example 32-7.1

Shown below are three possible cases defining horizontal curvature. In all three cases, it is assumed the curve starts at PC Sta 300 + 59.41 (English units) or the equivalent PC station in metric units of kilometer Sta 9 + 162.126.

Case A: English curve definition.

Case B: Metric definition assuming that Case A curve data defines the roadway centerline from a previous survey and will be retained. All curve data is a direct or soft conversion from English to metric units.

Case C: Metric definition of a paper relocation on mapping. The PC location will start at metric Sta 9 + 162.125 and have approximately the same curvature as the Case A curve. Therefore, R will be set at 580 m.

The following table illustrates the curve data for all three Cases.

Case A	Case B	Case C
PI Sta = 302 + 68.57	PI Sta = 9 + 225.879	PI Sta 9 + 225.646
$\Delta = 12^\circ 30'$	$\Delta = 12^\circ 30'$	$\Delta = 12^\circ 30'$
D = 3°00'	R = 582.125 m	R = 580.000 m
T = 209.16 ft	T = 63.753 m	T = 63.520 m
L = 416.67 ft	L = 127.000 m	L = 126.536 m

* * * * *

32-7.02 Chord Distances

When laying out a horizontal curve, the following guidelines are recommended for measuring chord distances around a curve. Where the radius is greater than 2000 ft (600 m), use 100 ft (25 m) chords. For radii between 2000 ft (600 m) and 800 ft (250 m), use 50 ft (15 m) chords. For radii between 800 ft (250 m) and 400 ft (125 m), use 25 ft (10 m) chords.

32-8 REFERENCES

1. *A Policy on Geometric Design of Highways and Streets*, AASHTO, 2004.
2. *Bureau of Engineering Manual – Part E*, City of Los Angeles, September 1970.
3. *Transition Curves for Highways*, Public Roads Administration, 1940.

