



CADD Structures Drafting Reference Guide

TABLE OF CONTENTS

1. Introduction	3
2. MicroStation Configuration Information	4
2.1. Configuration	4
2.2. Resource Files	4
2.3. Dgnlib Files	5
2.4. Levels / Symbology	5-6
2.5. Text Styles	7-8
2.6. Dimension Styles	8
2.7. Working Units	8-9
2.8. Models	9
2.9. Seed Files	9-10
2.10. Cell Libraries	10-11
2.11. Printing	12
3. General Detailing Information	13
3.1. Text	13-14
3.2. Capitalization	14
3.3. Abbreviations	14
3.4. Titles	15
3.5. Dimensioning	15-19
3.6. Patterning	20
3.7. Drawing Scales	20-21
3.8. MicroStation Issues	21
4. TSL and Final Plan Preparation	22
4.1. File Creation / Naming Convention	22
4.2. Roadway Data	22
4.3. Bridge Manual Checklists	22
4.4. Standards Checker	22
4.5. Final Plan Sheet Sequence	22-23
4.6. Guidelines	23
4.6.1. Type, Size and Location / General Plan and Elevation	23-24
4.6.2. Stage Construction Details	24-26
4.6.3. Top of Slab Elevations	27
4.6.4. Superstructure	27-28
4.6.5. Diaphragm Details (Integral Abutment)	28
4.6.6. Diaphragm Details (Semi-integral Abutment)	28
4.6.7. Framing Plan (steel, PPC I-beam or bulb T-beam)	28
4.6.8. Structural Steel Details	28
4.6.9. Abutments and Piers	29
4.6.10. Pile Base Sheets	29
4.6.11. Soil Boring Logs	29
5. Addendums	30
6. Construction Changes	31
7. Internet Information	32
7.1. Web Page	32
7.2. Subscription Service	32
8. District and Central Office CADD Manager Contact Information	32

1 Introduction

The reference guide herein contains basic MicroStation and structure detailing information that shall be used in the preparation of structure plans for the Illinois Department of Transportation. It is intended to be used in conjunction with the IDOT [CADD Roadway and Structure Project Deliverables Policy](#) and the Bureau of Bridges and Structures Manuals.

2.3 Dgnlib Files

Dgnlib's are design library files with predefined settings. When an element is placed in a design file, MicroStation "looks" to the dgnlib for that element's predefined properties or settings which then become part of the active design file. If changes are made to the dgnlib, they are not automatically updated in the design file. However, all or part of the settings can be updated from a revised dgnlib by executing the key-in command "dgnlib update (all, dimstyles, levels, etc.)". The available dgnlib's are:

- BridgeStyles.dgnlib - contains the text and dimension styles used in the preparation of structure plans.
- IDOTLevel2004.dgnlib - contains all of the levels with assigned symbology settings for the different disciplines within IDOT.

2.4 Levels / Symbology

Levels are set up in the file "IDOTLevel2004.dgnlib" for each department discipline (bridge, roadway, mapping, aerial surveys, etc.) within IDOT. All symbologies are preset within this dgnlib file. They include name, color number, line style and weight for each level. Before placing elements into a design file, first select the desired level. After selection, all of the associated symbology will be set automatically. There are instances where overriding these attributes is allowed. For structures, it is allowed on the levels named "Bridge_Pattern", "Bridge_Miscellaneous" and "Soils_Boring Logs". Filters have been set up to make it easier to locate a particular discipline's group of levels.

For structures, there are four major groups of levels. [Figure 2.4-1](#) shows a table containing all of the structure levels. These basic groups are as follows:

- Group 1: Design levels - specifically for the creation of structure design plans.
- Group 2: Planning levels - levels for the creation of the plan and elevation views of the Type, Size and Location (TSL) as well as the plan and elevation views of the General Plan and Elevation (GP&E). The other details on a TSL can make use of the Bridge_TSandL or the Bridge_Design levels depending on the desired appearance.
- Group 3: Border levels – specifically for borders.
- Group 4: Common levels - remaining levels are common to both planning and design.

For the TSL and GP&E, it is acceptable to utilize the roadway levels for elements such as topography and existing elements that are taken from the roadway design (either copied or referenced).

Level Name	Use
Group 1 : Design Levels	
Bridge_Addendum	Level used for addendums
Bridge_Construction Change	Level used for construction changes
Bridge_Design Concrete Hidden	Hidden concrete object line for design plans
Bridge_Design Concrete Object	Concrete object line for design plans
Bridge_Design Existing	Existing object line for design plans
Bridge_Design Reinforcement	Reinforcement object line for design plans
Bridge_Design Reinforcement Bending	Reinforcement bar bending diagram object line for design plans
Bridge_Design Reinforcement Existing	Existing reinforcement object line for design plans
Bridge_Design Reinforcement Hidden	Hidden reinforcement object line for design plans
Bridge_Design Steel Hidden	Hidden steel object line for design plans
Bridge_Design Steel Object	Steel object line for design plans
Soils_Boring Logs	Soil boring logs (symbology may vary)
Group 2: Planning Levels	
Bridge_TSandL Concrete Hidden	Hidden concrete object line for GP & E and TS & L
Bridge_TSandL Concrete Object	Concrete object line for GP & E and TS & L
Bridge_TSandL Existing	Existing object line for GP & E and TS & L
Bridge_TSandL Intermittent Stream	Intermittent stream object line for GP & E and TS & L
Bridge_TSandL Natural Ground	Natural ground object line for GP & E and TS & L
Bridge_TSandL Railroad	Railroad track line for GP & E and TS & L location sketch
Bridge_TSandL Reinforcement	Reinforcement object line for GP & E and TS & L
Bridge_TSandL Reinforcement Existing	Existing reinforcement object line for GP & E and TS & L
Bridge_TSandL Reinforcement Hidden	Hidden reinforcement object line for GP & E and TS & L
Bridge_TSandL Right of Way	Right of Way line for GP & E and TS & L
Bridge_TSandL Steel Hidden	Hidden steel object line for GP & E and TS & L
Bridge_TSandL Steel Object	Steel object line for GP & E and TS & L
Bridge_TSandL Streamline	Stream object line for GP & E and TS & L
Group 3: Border Levels	
Bridge_Sheet Border	Border level
Bridge_Sheet Design Plot	Design level for shape that can be used with batch plot
Bridge_Sheet Design Print	Design level for shape that can be used with batch plot
Bridge_Sheet TSandL Plot	Planning level for shape that can be used with batch plot
Bridge_Sheet TsandL Print	Planning level for shape that can be used with batch plot
Group 4: Common Levels	
Bridge_Breakline	Breakline (shift position if unable to see pattern)
Bridge_Centerline	Centerline (shift position if unable to see pattern)
Bridge_Construction Line	Level used for construction elements
Bridge_Cut or Match Line	Cut or match line (shift position if unable to see pattern)
Bridge_Dimensions and Text	General text and dimensions
Bridge_Markups	Level for revision notation for designers
Bridge_Miscellaneous	Level where symbology may vary
Bridge_Pattern	Patterning
Bridge_Riprap	Riprap
Bridge_Table Border	Heavy line for use with tables
Bridge_Table Lines	Thin lne for use with tables
Bridge_Title	Title level

Figure 2.4-1. Structure Levels

2.5 Text Styles

Text styles are a feature in MicroStation which greatly simplifies and standardizes the placement of text. When placing text, simply picking a text style automatically adjusts the text settings. It is no longer necessary to manually change font, text height, text width, line spacing or other properties independently.

Five text styles listed in Fig. 2.5.1 were created for use in the creation of structure plans. These text styles were set up using the data presented in Fig. 2.5-2. They exist in the file named "BridgeStyles.dgnlib".

Text styles	Use
Br1:001scale100	Subscript and superscript
Br1:001scale140	Callouts, dimensions and notes
Br1:001scale200	Titles
Br1:001scale_boring	In-house boring log text
Br1:001scale_TOS_Elev	Top of slab elevation table text

Figure 2.5-1. Text Styles for ANSI D-size Structure Plans

Text Style Settings					
	font	height (in inches)	width (in inches)	line spacing (in inches)	underline
General text	30	0.14	0.14	0.10	no
Subscripts	30	0.10	0.10	NA	no
Top of Slab Elevations	31	0.14	0.14	0.10	no
Boring log text	107	0.09	0.09	NA	no
Titles	30	0.20	0.20	0.20	yes*

Figure 2.5-2. Text Style Settings for ANSI D-size Structure Plans

In order to use text styles, one must understand that the text styles have been set up relative to the ANSI D-sized border which is literally 22" x 34". Unlike the roadway borders, the structure borders are not scaled twelve times in the bridge cell library. This is so that either the architectural or engineering scales could easily be chosen without requiring the annotation scale to be different than the scale factor used in placing the border.

Section 3.7 briefly discusses four methods of drawing, the first two not requiring the use of the annotation scale feature in MicroStation. If the latter two are used, the annotation scale feature must be used.

In order to use the annotation scale, two things must be done. First, the annotation scale must be set in each of the target models. This is currently done through the Models dialog. Even if models are not intended to be used, each design file does contain at least one model, the default model. The Models dialog may be accessed either from the Primary Tools toolbar or from the File pulldown. Once available, the Model Properties must be edited by selecting the Edit Model Properties icon. This brings up another dialog where the annotation scale is actually set. It should appear similar to what is shown in Fig. 2.5-3. The pulldown in the middle of the dialog acquires the proper annotation scale from the file "scales.def" that is included in the IDOT configuration. You can see that if the scale of 1"=50' is chosen, that the annotation

scale to the right of it is greyed out and set at 600:1. The second thing that must be done is that the Annotation Scale lock must be turned on. This can be done through the pull-down “Settings/Locks/Annotation Scale”. The settings should be saved at this time. From this point on, text will be scaled up whatever the annotation scale is set to.

One thing that should be mentioned here is that the text settings generally should not be overridden. Two exceptions are with the justification and occasionally the underline. Changing other settings goes against the standardization that can be obtained by using text styles.

Use caution in the dgnlib update command. If the dgnlib update command is run against a file with text or dimension styles already used, any overrides will be changed back to the default settings of the associated text style or dimension style.

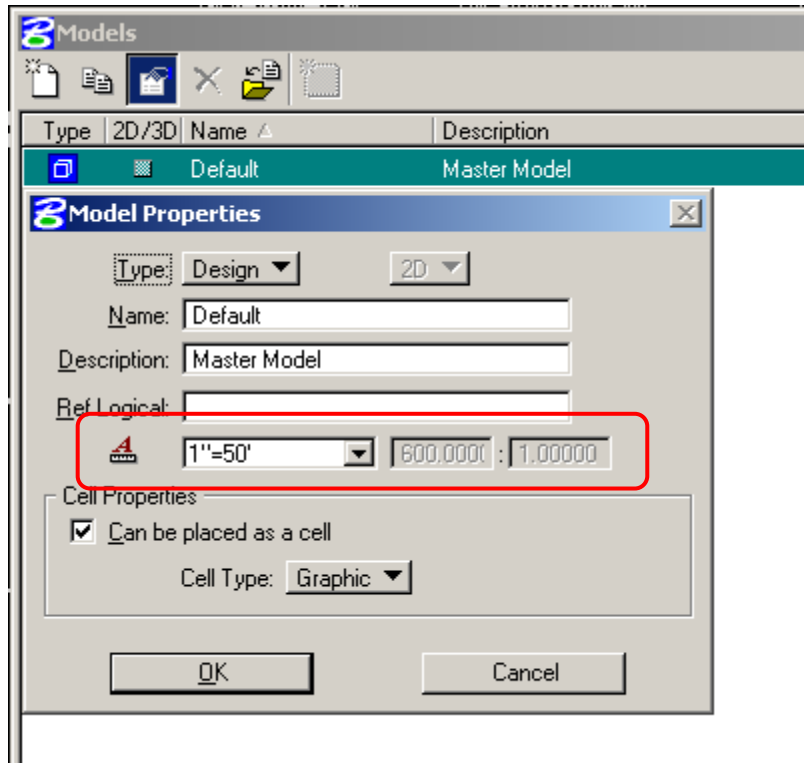

Fig. 2.5-3. Model Properties Dialog

2.6 Dimension Styles

Dimension styles are a feature in MicroStation which simplifies placement of dimensions and promotes uniformity in dimensions. Similar to text styles, the dimension settings are pre-defined inside of “BridgeStyles.dgnlib”. They also may require that the annotation scale be set and turned on in order for them to work properly.

Refer to [Section 3.5](#) for further discussion of dimensioning and the use of dimension styles.

2.7 Working Units

The working units are now set in survey feet as the master units and survey inches are set as the sub-units in order to match those used in the preparation of roadway plans. The resolution is set to 1000 units per survey foot with the global origin set to 0,0.

These new settings allow for the use of electronic roadway data as well as auto-dimensioning.

2.8 Models

One of the major changes in MicroStation is the addition of design models. The model concept allows for multiple drawings (design models) within a single design file. The Bureau of Bridges and Structures is utilizing the model concept by creating each sheet of a set of design plans in its own design model. Use of the model concept in the preparation of structure plans is not mandatory. It is acceptable to have individual design files for each sheet. A sample project has been placed on the Bureau of Bridges and Structures Web Site to illustrate both methods. (These are not intended to depict the most current policy). They are available at: <http://www.dot.il.gov/bridges/bscadd2.html>

2.9 Seed Files

Two seed files are available for the preparation of structure plans. One is named “ebridge_models.dgn” and the other is entitled “ebridge_individual.dgn”.

The “ebridge_models.dgn” file contains design and planning models in which ANSI D-sized borders have been placed. Additional models intended for sheets and full scale details intended for sheets and full scale details may be added as required. The ebridge_models.dgn seed file should be chosen if a single design file is to be employed for an entire job. Figure 2.9-1 provides a screen capture showing the contents of this seed file.

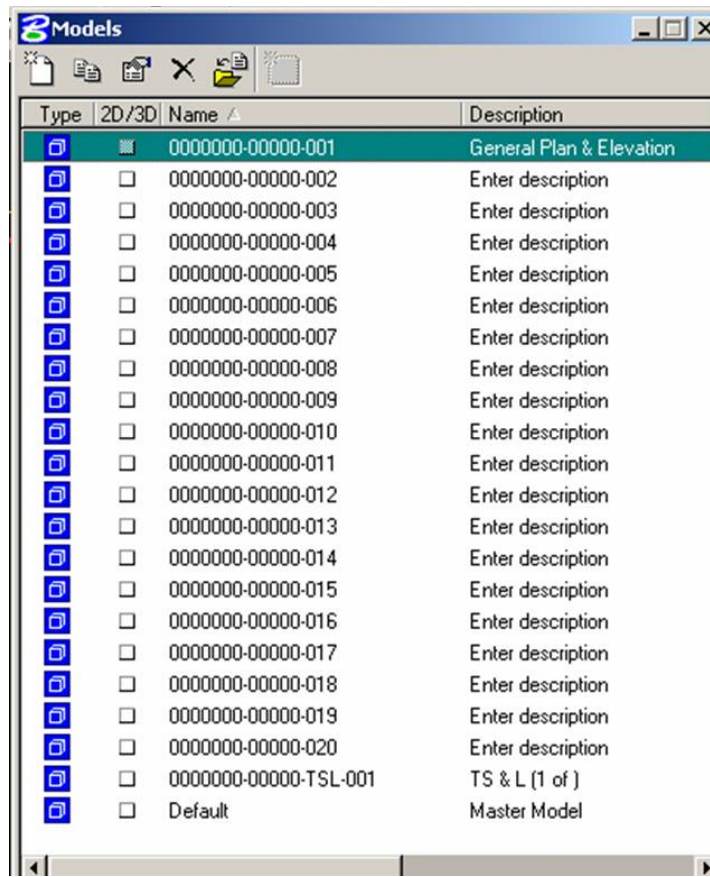

Type	2D/3D	Name	Description
<input checked="" type="checkbox"/>		0000000-00000-001	General Plan & Elevation
<input type="checkbox"/>		0000000-00000-002	Enter description
<input type="checkbox"/>		0000000-00000-003	Enter description
<input type="checkbox"/>		0000000-00000-004	Enter description
<input type="checkbox"/>		0000000-00000-005	Enter description
<input type="checkbox"/>		0000000-00000-006	Enter description
<input type="checkbox"/>		0000000-00000-007	Enter description
<input type="checkbox"/>		0000000-00000-008	Enter description
<input type="checkbox"/>		0000000-00000-009	Enter description
<input type="checkbox"/>		0000000-00000-010	Enter description
<input type="checkbox"/>		0000000-00000-011	Enter description
<input type="checkbox"/>		0000000-00000-012	Enter description
<input type="checkbox"/>		0000000-00000-013	Enter description
<input type="checkbox"/>		0000000-00000-014	Enter description
<input type="checkbox"/>		0000000-00000-015	Enter description
<input type="checkbox"/>		0000000-00000-016	Enter description
<input type="checkbox"/>		0000000-00000-017	Enter description
<input type="checkbox"/>		0000000-00000-018	Enter description
<input type="checkbox"/>		0000000-00000-019	Enter description
<input type="checkbox"/>		0000000-00000-020	Enter description
<input type="checkbox"/>		0000000-00000-TSL-001	TS & L (1 of)
<input type="checkbox"/>		Default	Master Model

Figure 2.9-1. Contents of Seed File “ebridge_models.dgn”

The “ebridge_individual.dgn” file contains a single design model with a design border inserted. This seed file should be chosen if an individual design file is utilized for each sheet in a job. [Figure 2.9-2](#) provides a screen capture showing the contents of the ebridge_individual.dgn seed file.

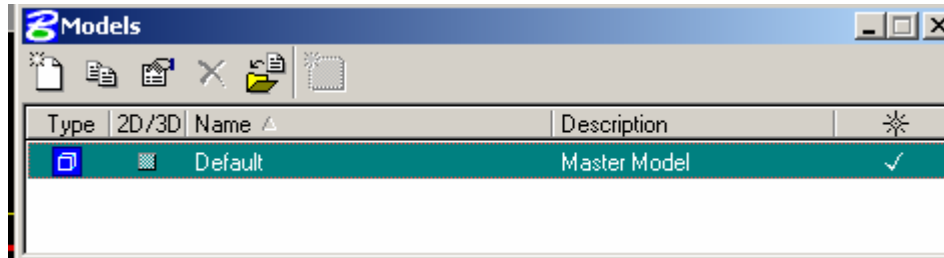

Figure 2.9-2. Contents of Seed File “ebridge_individual.dgn”

For both seed files, the borders are placed with the lower left hand corner of the inner border (working area) at $xy=0,0$.

The file naming requirements for design files and models are discussed in the [CADD Roadway and Structure Project Deliverables Policy](#). Model names and descriptions are easily changed by slowly double-clicking on a model in the models dialog or else they may be changed in the “Edit Model Properties” dialog.

2.10 Cell Libraries

Although the cell libraries appear as in previous versions of MicroStation, they are quite different. Cell libraries are now drawings that utilize the design model concept, but maintain the previous file extension of “cel”. Each “cell” in a cell library is a design model. However, the cell libraries can be used in a similar manner to previous versions of MicroStation. They can be imported into a design file using the models dialog, or opened and manipulated just as any other design file.

The Bureau of Bridges and Structures has several cell libraries available to aid in the preparation of structure plans. Most of the libraries contain “base sheets” which are either complete, or require some modification in order to be included with a set of design plans. The Bureau of Bridges and Structures periodically updates these base sheets and revised copies are placed on the Bureau’s Web Site. E-mails are sent to subscribers of the IDOT Bureau of Bridges and Structures Subscription Service whenever these updates are posted on the Internet. The other available cell libraries contain individual details or elements that can be used for structure plan preparation. E-mail notifications are also sent out when these are updated. (See [Section 7.2](#)).

Adobe Acrobat “pdf” files have also been created for each of the cell libraries and are available on the BBS Web Site. Each pdf contains a table of contents and individual images of the cells or base sheet cells. The table of contents for each library contains links to each of the cell images.

[Figure 2.10-1](#) presents a list of the structure libraries and their contents.

Details, symbols and notes

bridge.cel	Patterns, symbols and full size bridge objects
details.cel	Bridge design details (not included with base sheets)
general_notes.cel	General notes for placement on GP & E or general data sheet
pay_items.cel	Pay items for Total Bill of Material on GP & E or general data sheet
planning.cel	Planning details for TS & L and GP & E

Bridge base sheets

PPC_deckbeam.cel	PPC Deck beam superstructure
prestressed.cel	Superstructure (PPC I-beams and Bulb T-beams)
substructure.cel	Substructure (abutments, piers and piles)
superstructure.cel	Superstructure (deck, bearings, railings, scuppers, diaphragms)

Culvert base sheets

single_box_culvert.cel	single box culvert with horizontal cantilever, T type or L type wingwalls
double_box_culvert.cel	double box culvert with horizontal cantilever, T type or L type wingwalls

Retired Bridge Standard Plans drafting aids

24_ft_rdwy_engsup.cel	PPC deck beam superstructure
27_ft_rdwy_engsup.cel	PPC deck beam superstructure
28_ft_rdwy_engsup.cel	PPC deck beam superstructure
30_ft_rdwy_engsup.cel	PPC deck beam superstructure
33_ft_rdwy_engsup.cel	PPC deck beam superstructure
all_egn_abut.cel	PPC deck beam pile bent abutments
all_eng_beam_details.cel	PPC deck beam details
all_eng_pier.cel	PPC deck beam pile bent piers
standard_plans_gpe.cel	GP & E's for PPC deck beam bridges

Archived base sheets and details

miscellaneous.cel	Old details and base sheets that are not for new projects
-------------------	---

Sign structure base sheets

alum_butterfly_sign.cel	Aluminum butterfly sign structures
alum_cantilever_sign.cel	Aluminum cantilever sign structures
alum_simple_span_sign.cel	Aluminum simple span sign structures
breakaway_tubular_steel_sign.cel	Breakaway tubular steel signposts
breakaway_wf_steel_sign.cel	Breakaway wide flange steel signposts
bridge_mounted_sign.cel	Bridge mounted sign structures
monotube_sign.cel	Monotube sign structures
steel_cantilever_sign.cel	Steel cantilever sign structures
steel_simple_span_sign.cel	Steel simple span sign structures
steel_trichord_sign.cel	Steel trichord sign structures

Figure 2.10-1. Structure Libraries and Contents

2.11 Printing

The borders provided in the cell library “bridge.cel” are set up to facilitate the use of MicroStation’s Batch Plotting feature. There are two shapes on different levels. The inner shape is used for printing to an ANSI B-size sheet while the outer shape is set up to print the ANSI D-size border onto a 36” wide roll of paper allowing ½” on each side for a printer’s non-printable area.

Figure 2.11-1 is a table showing the line thicknesses used on full size (ANSI D) prints. The line thicknesses for quarter-size (ANSI B) plans should be set to one-half of these values.

In a similar manner, Figure 2.11-2 is a table showing the line strokes used on full size (ANSI D) prints used to define MicroStation’s built-in line codes. The line strokes for quarter-size (ANSI B) plans should be set to one-half of these values.

Weight WT =	Thickness (in)	Thickness (mm)	Pen Size
0	0.010	0.250	000
1	0.014	0.350	0
2	0.020	0.500	1
3	0.024	0.600	2
4	0.031	0.800	3
5	0.047	1.200	4

Figure 2.11-1. Line Thicknesses for ANSI D-size Prints

Line Code LC =	Line (in)	Space (in)	Line (in)	Space (in)	Line (in)	Space (in)
1	0.015	0.0394				
2	0.0788	0.0788				
3	0.1574	0.0788				
4	0.1574	0.0788	0.0236	0.0788		
5	0.0552	0.0552				
6	0.1574	0.0552	0.0394	0.0552	0.0394	0.0552
7	0.1574	0.0552	0.0552	0.0552		

Figure 2.11-2. Line strokes for ANSI D-size Prints

3 General Detailing Information

3.1 Text

The text styles discussed in the MicroStation Configuration Information section ([Section 2.5](#)) shall be used in the preparation of structure plans in order to provide uniformity in appearance.

The following is information regarding how text should be placed in structure plans:

- Words that are abbreviated should not be capitalized or put in parentheses. Examples are “typ.,” “min.” and “max.”
- When using asterisks for a reference note, place the asterisk as a separate text entity to the left of the note as follows:
 - * Tightly fasten the #8 bars together
With No. 9 wire ties.
- When placing a note under a title of a section which applies to that section, do not use “Note:”. Only use “Note:” for a block of notes that are grouped or listed together in one location on a sheet.
- The words “wingwall”, “streambed” and “headwall” have been shown both as single words (wingwall) and as separate words (wing wall). They should always be shown as single words.
- The plus-or-minus symbol (“±”) shall be placed before approximate dimensions unless showing a specific tolerance. A specific tolerance should be shown in parentheses following the dimension.
- Avoid use of the note “Work this sheet with sheet...”. Use of a note such as this can become cumbersome and usually provides little benefit.
- Do not call out the route number within a job unless it is the centerline of a divided highway. Call out the centerline of roadway (and PG if applicable).
- Notes that are a part of any of the BBS base sheets should generally remain on the base sheet. As an example, the note “A distance of half the length of the wingwall but not less than six feet of the barrel shall be poured monolithically with the wingwalls” is occasionally moved or reworded on the GP&E. This note should not be moved or reworded unless a unique situation requires it.
- All notes should be left justified. An exception is when a multi-line callout is placed between arrows of a dimension. In this case, it can either be left or center justified. If it is left justified, try to make each line of text approximately the same length.
- The Bill of Material for individual elements, such as superstructure, abutment, pier, etc., should contain only the items that are listed in BBS base sheets. Showing all of the pay items for each of the structure elements on these sheets is unnecessary. All of the pay items are shown on the total bill of material.
- For appearance, the reinforcement bars should be listed in the bill of material with a blank line between the bar groupings, e.g. show a blank line between b bars and d bars.
- When referencing sheets, do not write “See sheet #3 of #15”, instead use “See sheet 3 of 15”.
- Slopes shall be listed as “1:X (V:H)” [e.g. “1:2 (V:H)”] as opposed to “2:1” which was shown in the past and implied “horizontal:vertical”.
- Cross slopes shall be denoted in inches per foot (“/ft) unless there is a super-elevation.

- Generally, span numbers do not need to be called out. An exception to this could be a large structure with many spans.
- When calling out the centerline of a pier, do not call it out as centerline bearing pier __. There are instances when the centerline bearing and centerline pier are not the same. It is preferable to either use two separate labels or to write “Centerline bearing and centerline pier”.
- Callouts for reinforcement bar spacing, steel plates, and bearing plates may be shown in inches. However, plan view dimensions for reinforcement bars and bearing plate details shall be shown in feet and inches.
- Concrete dimensions shall be shown in feet and inches. If a concrete dimension is less than 1'-0", it shall be shown in inches.

3.2 Capitalization

As a general rule, capitalize the first letter of the first word of a note or sentence as well as proper names. There are two basic exceptions. One is contractual parties such as Engineer and Contractor. The other basic exception is pay items. The first letter of each word of the pay item should be capitalized except for words such as “of”, “and”, “for” or “in”.

3.3 Abbreviations

Figure 3.3-1 contains a basic list of acceptable abbreviations that may be used when necessary. Generally try to spell words out unless there is a problem with space. Periods do not need to be placed within abbreviations of proper names such as AASHTO.

<i>abut.</i>	<i>abutment</i>	<i>min.</i>	<i>minimum</i>
<i>B.F.</i>	<i>back face</i>	<i>no.</i>	<i>number</i>
\bar{B}	<i>baseline</i>	<i>O.F.</i>	<i>outside face</i>
<i>brg.</i>	<i>bearing</i>	<i>PJF</i>	<i>prefomed joint filler</i>
\bar{C}	<i>centerline</i>	<i>PJS</i>	<i>prefomed joint sealer</i>
<i>cl.</i>	<i>clearance</i>	<i>PG</i>	<i>profile grade</i>
<i>conc.</i>	<i>concrete</i>	<i>prop.</i>	<i>proposed</i>
<i>const.</i>	<i>construction</i>	<i>rte.</i>	<i>route</i>
ϕ	<i>diameter</i>	<i>sect.</i>	<i>section</i>
<i>E.F.</i>	<i>each face</i>	<i>sta.</i>	<i>station</i>
<i>elev.</i>	<i>elevation</i>	<i>struct.</i>	<i>structure</i>
<i>exist.</i>	<i>existing</i>	<i>typ.</i>	<i>typical</i>
\bar{F}	<i>flowline</i>	<i>req'd.</i>	<i>required</i>
<i>F.F.</i>	<i>front face</i>	<i>spa.</i>	<i>spaces</i>
<i>I.F.</i>	<i>inside face</i>	<i>std.</i>	<i>standard</i>
<i>jt.</i>	<i>joint</i>	<i>spec.</i>	<i>specification</i>
<i>long.</i>	<i>longitudinal</i>		
<i>max.</i>	<i>maximum</i>		

Figure 3.3-1. Basic List of Acceptable Abbreviations

3.4 Titles

The guidelines listed below shall be followed when placing titles for sheets or for individual details:

- Both the planning TS & L sheet(s) and the design GP & E should show the sheet name, crossing, route, section, county, station and structure number as follows:

GENERAL PLAN & ELEVATION
ILLINOIS ROUTE 23 OVER VERMILION RIVER
F.A.P. RT. 68 SEC. 102-BR
LIVINGSTON COUNTY
STATION 25+10.18
STRUCTURE NO. 053-0177

- For all other sheets of the design plans, only the sheet name and structure number should be shown as follows:

SUPERSTRUCTURE DETAILS
STRUCTURE NO. 053-0177

- All the lines of a title block should be underlined (this includes on a TSL and a GP&E). As long as the proper text style is used, the justification, spacing, text size and underlining will appear correctly. (Note that in MicroStation, Workspace/Preferences/Text/Underline Spacing (%) needs to be set to 33).
- There has been a tendency at times to make detail titles somewhat lengthy or wordy. This should be avoided. If detail titles require further description, it should be done in standard text below the title.

3.5 Dimensioning

The BBS currently places dimensions manually using line terminators. However the dimension style "Bridge1:001" has been created and may be used instead of, or in addition to, manually placed dimensions. It is important to note that only basic settings have been pre-defined for this dimension style. It is likely some changes will be required to these settings for use in a project. However, some potential problems can be avoided by not executing the "dgnlib update" command for the dimensions after the dimension style has been modified. Once a dimension is placed in a design file, those properties then become a part of the design file.

Whether manually placing dimensions or employing the dimension style, the proper arrowhead B00021 from the cell library "bridge.cel" should be used.

Guidelines for the placement of dimensions or callouts are as follows:

- Dimension stack spacing should be $\frac{1}{2}$ ", although $\frac{3}{8}$ " is acceptable if there are space constraints. The extension lines should extend $\frac{1}{16}$ " beyond the dimension line. See [Figure 3.5-1 \(Detail "a"\)](#).
- Dimension lines should not be broken unless passing through another dimension or text. See [Figure 3.5-1 \(Detail "b"\)](#).
- Generally, do not break or mask object lines for dimension lines unless there is interference with an arrowhead or text. See [Figure 3.5-1 \(Detail "c"\)](#).

- If the active angle when placing text is between 90 degrees and 105 degrees, the text should be placed such that it can be read from the right of the sheet. If the angle is greater than 105 degrees, it should be placed such that it can be read from the left or bottom. [See Figure 3.5-2.](#)
- It is acceptable to show reinforcement dimensions with double arrows or by pointing to the first and last bar. Consistency with a chosen style is important.
- If there is no skew on a structure, there is no need to dimension a 90 degree angle throughout the job. This angle should only be shown on the TSL and GP&E.
- Avoid causing callouts to pass through lines of dimensions. [See Figure 3.5-3.](#)

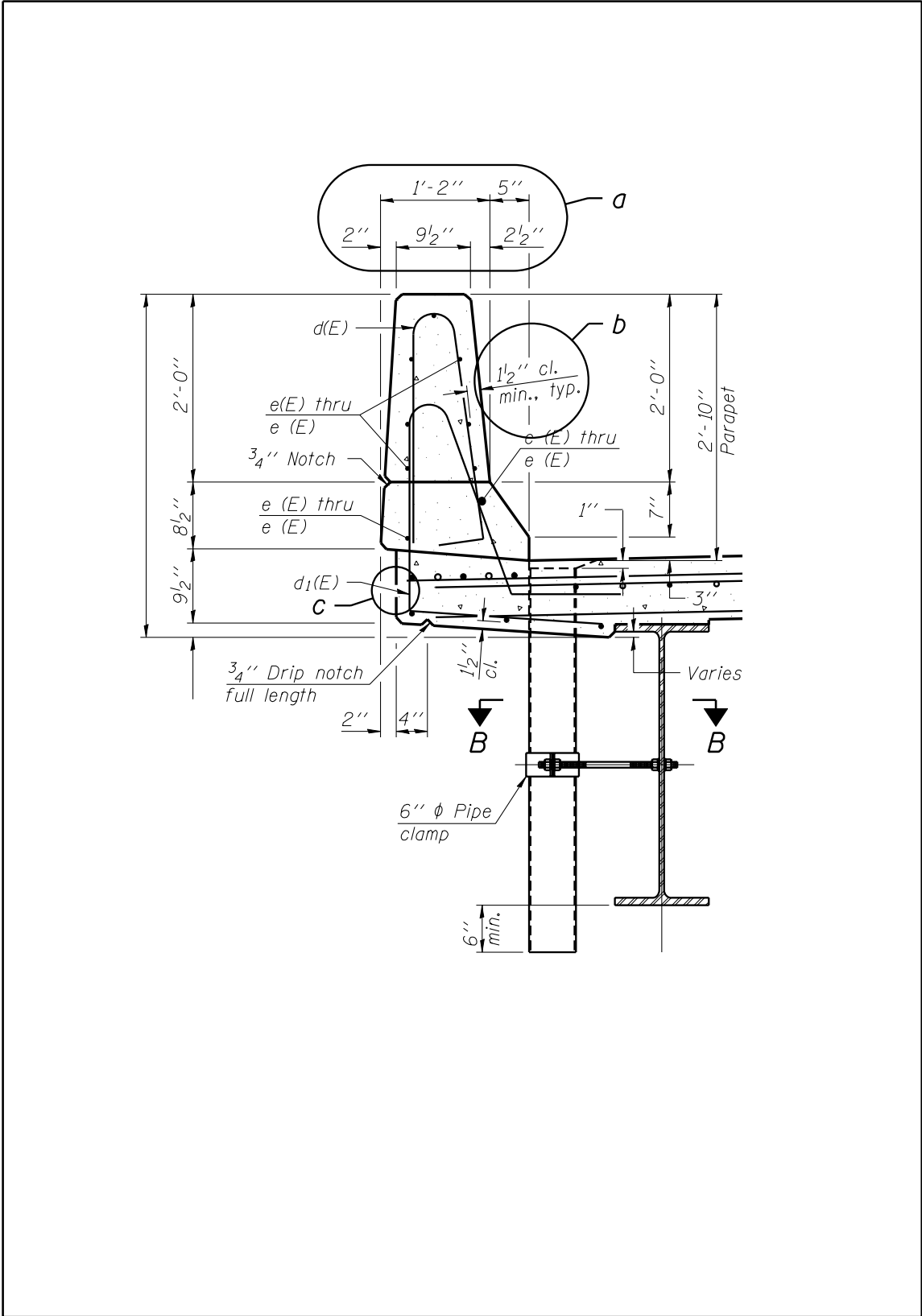

Figure 3.5-1. Dimension Placement and Callouts (Example #1)

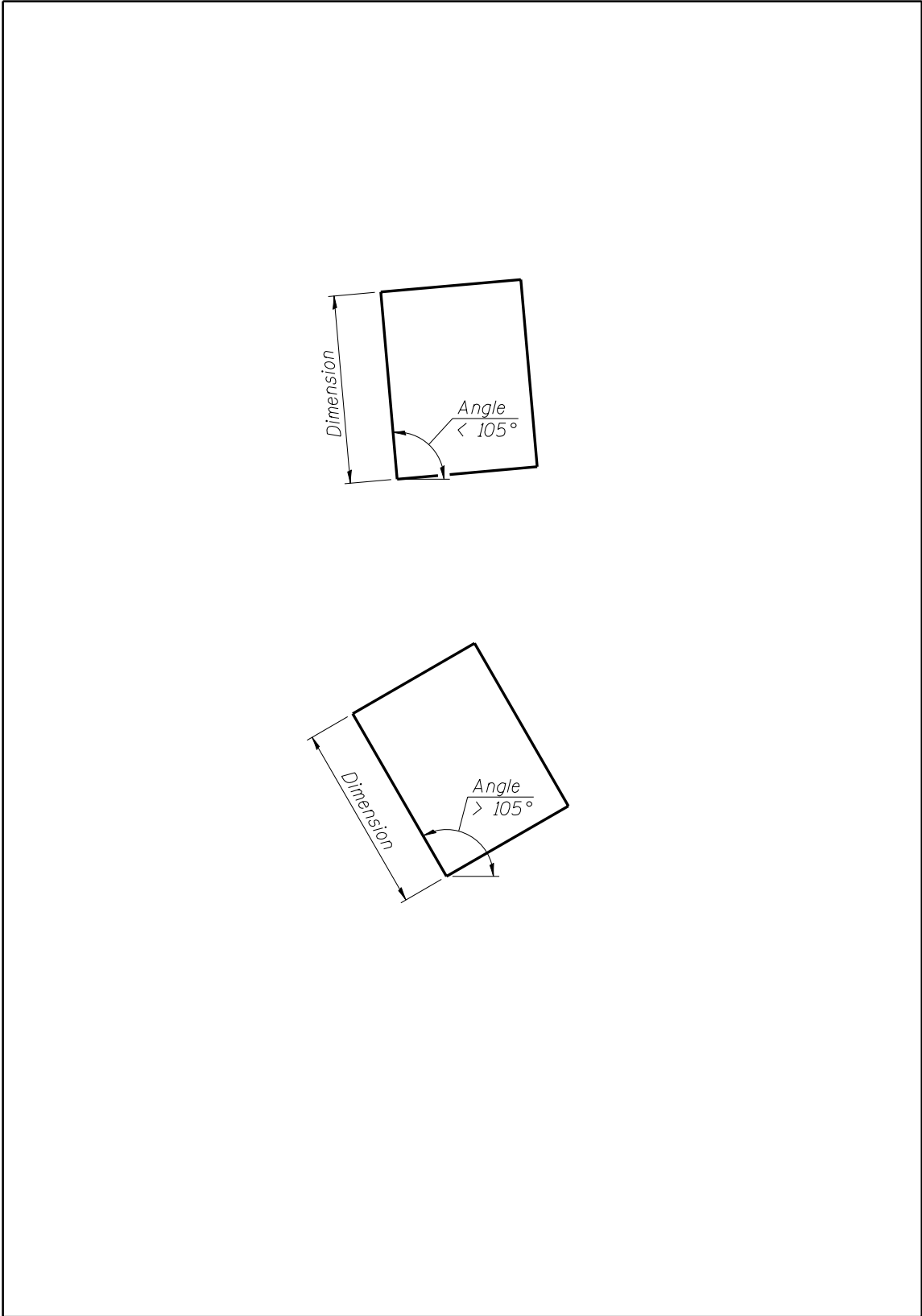

Figure 3.5-2. Dimension Placement and Callouts (Example #2)

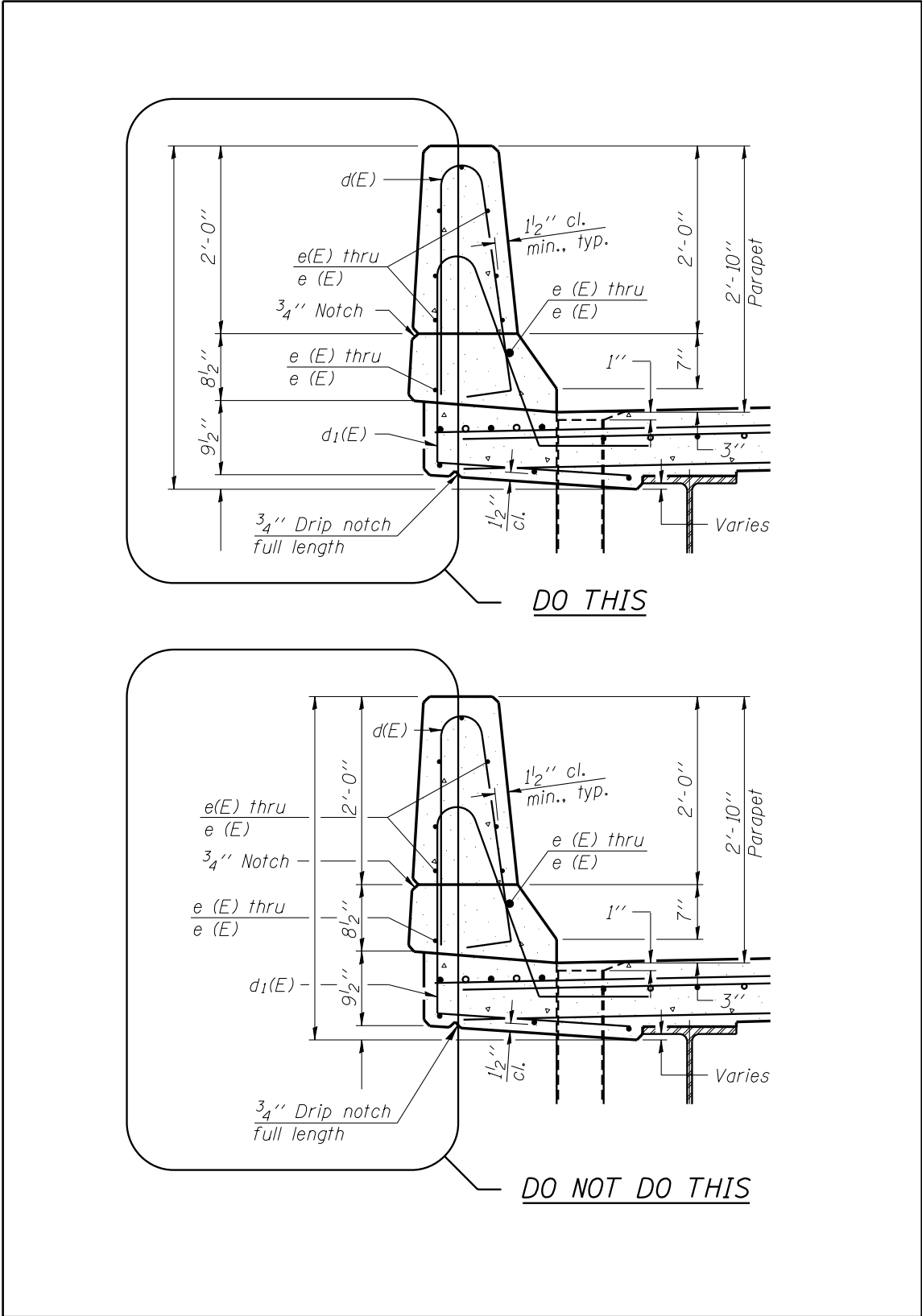

Figure 3.5-3. Dimension Placement and Callouts (Example #3)

3.6 Patterning

Several different patterns exist in “bridge.cel” for general use. They include both area patterns and linear patterns. The area patterns are generally used for section cuts. The linear patterns are not essential due to the creation of the BBS custom line styles. However it is still acceptable to use the linear patterns.

Suggested guidelines for the placement of patterns are as follows:

- Whenever a section is cut through any material, the surfaces touched by the cutting plane should be patterned using the proper pattern (stipple or hatching).
- End views should not be patterned as if they are sections.

3.7 Drawing Scales

Although drawings do not have to be drawn “to scale”, many times it is beneficial to do so. If details are not drawn to scale, they should always be proportionate. [Figure 3.7-1](#) lists the common architectural and engineering scales that should be used.

There are different methods of drawing plans to scale. Four of the methods that can be used are as follows:

- Draw full scale to the side, scaling it down by $1 / \text{scale factor}$. The newer base sheets have been drawn using this method such that they could be contained in individual cells of a cell library in a uniform manner. The annotation scale is not set in this method.
- Draw full scale in a separate design model or design file other than the border. From within the file (or model) containing the border, the full scale drawings are referenced in at $1 / \text{scale factor}$. Text and dimensions can be placed either in the design file (or model) with the border or in the design file (or model) with the full scale drawing. Employment of the annotation scale feature is necessary if the text and dimensions are placed in the design file (or model) containing the full scale drawing. See Section 2.5 for information concerning the annotation scale.
- Draw full scale, inserting the border at the desired scale factor into the same design file (or model). Text and dimensions are required to be placed using the annotation scale feature. See Section 2.5 for information concerning the annotation scale.
- Reference full scale drawing at 1:1 into file (or model) containing a border scaled up by the desired scale factor. Employment of the annotation scale feature is necessary whether the text and/or dimensions are placed in the file containing the border or else in the file that is referenced. See Section 2.5 for information concerning the annotation scale.

There are advantages and disadvantages to each of the above methods. The Bureau of Bridges and Structures typically uses the first or the second method. The sample drawings on the Bridges and Structures CADD Support Web Page provide examples of the first two methods.

Architectural Scales	
	Scale
1:192	1/16" = 1'-0"
1:128	3/32" = 1'-0"
1:96	1/8" = 1'-0"
1:64	3/16" = 1'-0"
1:48	1/4" = 1'-0"
1:32	3/8" = 1'-0"
1:24	1/2" = 1'-0"
1:16	3/4" = 1'-0"
1:12	1" = 1'-0"
1:8	1 1/2" = 1'-0"
1:4	3" = 1'-0"

Engineering Scales	
	Scale
1:2400	1" = 200'
1:1200	1" = 100'
1:720	1" = 60'
1:600	1" = 50'
1:480	1" = 40'
1:360	1" = 30'
1:240	1" = 20'
1:120	1" = 10'
1:60	1" = 5'

Figure 3.7-1. Common Architectural and Engineering Scales

3.8 MicroStation Issues

There is a known issue with MicroStation where text using our font 30 is used to place fractions alone. Generally, this only occurs within weld callouts. If a dgn is compressed with the "Delete Text Elements Containing Only Spaces" toggled on, fractions will randomly be deleted if placed alone without units. To avoid any problems, make sure that you toggle the "Delete Text Elements Containing Only Spaces" off (as shown in Fig. 3.8-1) before compressing any design files.

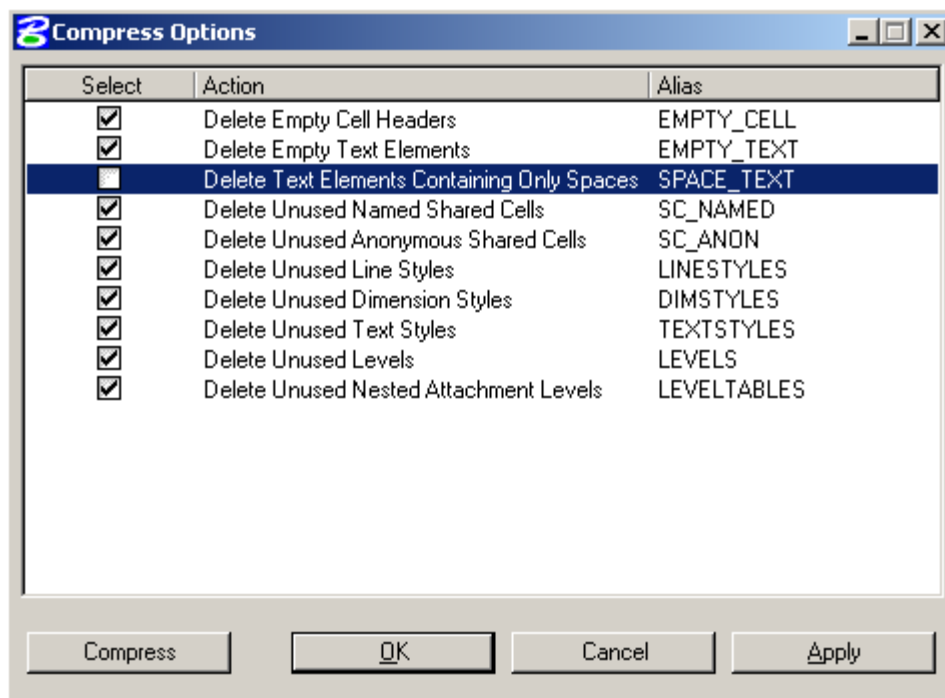

Fig. 3.8-1. Compress Options Dialog

4 TSL and Final Plan Preparation

4.1 File Creation / Naming Convention

As stated in [Section 2.8](#) of this Guide, individual design files or design files containing models may be used when creating TSL's or design plans. In either case, the seed files from the BBS Web Site (<http://www.dot.il.gov/bridges/bscadd2.html>) shall be utilized.

The file naming conventions for TSL's and design plans are covered in the [CADD Roadway and Structure Project Deliverable Policy](#).

4.2 Roadway Data

When creating a TSL, GP&E or other details where roadway information is used, it is acceptable to either incorporate the roadway information (such as the topography) into a project's design file/model, or reference this data from the roadway files into the design file/model. In either case, it is acceptable to use the roadway levels and line styles for this information. Changing these elements to the structure levels is not required.

4.3 Bridge Manual Checklists

The Bridge Manual contains checklists for the preparation of TSL's and final design plans.

For TSL's, the checklists begin in Section 2.3.13.1. There are example TSL's for a variety of projects available at: <http://www.dot.il.gov/bridges/examples.html>.

For final design plans, the checklist is located in Section 3.1.13.

4.4 Standards Checker

The Standards Checker files exist in the CADD environment discussed in [Section 2.1](#). Instructions on its use from within MicroStation are in the directory containing the dgnlib files. It is titled [MicroStation Standards Checker.doc](#). It is important to note that the instructions work for projects in which individual design files are provided for each sheet of the plans. For projects where multiple design models are contained within a single design file, the Standards Checker is required to be run as a batch process under Utilities/Batch Process.

4.5 Final Plan Sheet Sequence

Design plans should be sequenced as follows:

- General Plan and Elevation (GP&E)
- General Data (except for simple structures)
- Footing Layout (if required)
- Stage Construction Details (if required)
- Temporary Barrier or Temporary Railing Details (if required)
- Top of Slab Elevations
- Top of Approach Slab Elevations
- Superstructure (Plan and Cross Section)
- Superstructure Details
- Diaphragm Details (for bridges with integral or semi-integral abutments)

- Bridge Approach Slab Details
- Bridge Railing Details
- Expansion Joint Details
- Drainage Scuppers
- Girder and Framing Details (Steel or Concrete)
- Bearing Details
- Abutment Details
- Pier Details
- Foundation Details (includes piles)
- Bar Splicer Assembly Details
- Cantilever Forming Brackets
- Soil Boring Logs

4.6 Guidelines

Sections 4.6.1 through 4.6.11 contain a collection of guidelines that should be followed when working with any structure plans. Questions and problems that have been encountered over the years led to their creation. The information has been grouped together by plan sheet type.

4.6.1 Type, Size and Location / General Plan and Elevation

The following guidelines should be used when creating a TSL or GP&E:

- TSL and GP&E plan views should be as uncluttered as possible. Utilities, adjacent structures or topography not directly related to constructing the structure need not be shown.
- The total bill of materials and general notes should typically be shown on a general data sheet immediately following the GP&E. For simple jobs, this information can be shown on the GP&E and a general data sheet may be omitted.
- For structure plans, do not show the direction of the stationing increase on the TSL or GP&E except for culverts and three-sided structures. Structures should usually be shown with stationing increasing from left to right.
- The design consultant firm name should be included in, or near, the title block on each structure plan sheet.
- Include the designer's, checker's and technician's initials on each plan sheet. A data block exists in the lower left corner of BBS borders for this information.
- Be sure to include an index of structure sheets on the GP&E or general data sheet.
- The contract number should be placed on each sheet of the design plans in the lower right corner. A text entity is included on BBS borders for this.
- Showing the centerline of structure throughout the plans is unnecessary unless dimensions are tied to it. It should be called out on the TSL and GP&E.
- Calling out the traffic barrier terminals in both the plan and the elevation views of the TSL or GP&E is unnecessary.
- For a re-decking job, the existing name plate typically is cleaned and relocated adjacent to the new name plate. This information shall be provided in a note below the name plate detail rather than showing its location in the plan of the GP&E.

- For partially rebuilt structures, the new name plate should indicate “Re-built” on the GP&E.
- Pay items should be listed in order by pay code number in the total bill of material of the GP&E although the pay code numbers themselves are not shown on the structure plans. This provides for some uniformity between projects and reduces the chances of omitting required pay items.
- For GP&E’s, try to present the general notes in the order that they appear in the Bridge Manual. This makes plans more uniform and easier to verify that the required notes have been included.

4.6.2 Stage Construction Details

Figures 4.6.2-1 and 4.6.2-2 show the acceptable method of detailing the removal and construction cross sections. The guidelines below should be used when creating stage construction details:

- If a project utilizes stage construction, there should be an offset dimension from the centerline of roadway, or other primary survey line, to the stage line and all other dimensions shall be from the stage line.
- Call out the temporary concrete barrier and/or temporary bridge rail and locate with dimensions in stage I and II removal cross sections only.
- Do not dimension actual distances on the cross sections for stage removal or stage construction.
- The widths of the stage I and II traffic lanes should be dimensioned.
- Provide the dimension from the centerline of roadway to the stage construction joint in the stage I construction cross section only.
- Do not call out a “stage construction line”. This is redundant and understood because of the stage I and stage II construction callouts.
- In the notes, indicate which direction the cross sections are viewed. Do not indicate the direction under each cross section.
- Deck cross sections should be looking in the direction of increasing station.
- Avoid repeating any dimensions that are shown on a previous cross section.
- Only call out the existing bridge rail if it is being salvaged.
- Temporary soil retention details and notes should be placed on this sheet unless there is insufficient room and a separate sheet is necessary.

Additional guidelines for stage detailing throughout a job are as follows:

- Bar splicer callouts should be listed in the following manner: “9 bar splicers for #5 a3(E) bars”, where the a3(E) are stage I bars.
- Stage construction line and/or joint callouts do not need to be repeated in every view on a sheet.
- The stage construction line does not need to be labeled if other callouts indicate the staging. This redundancy is unnecessary.

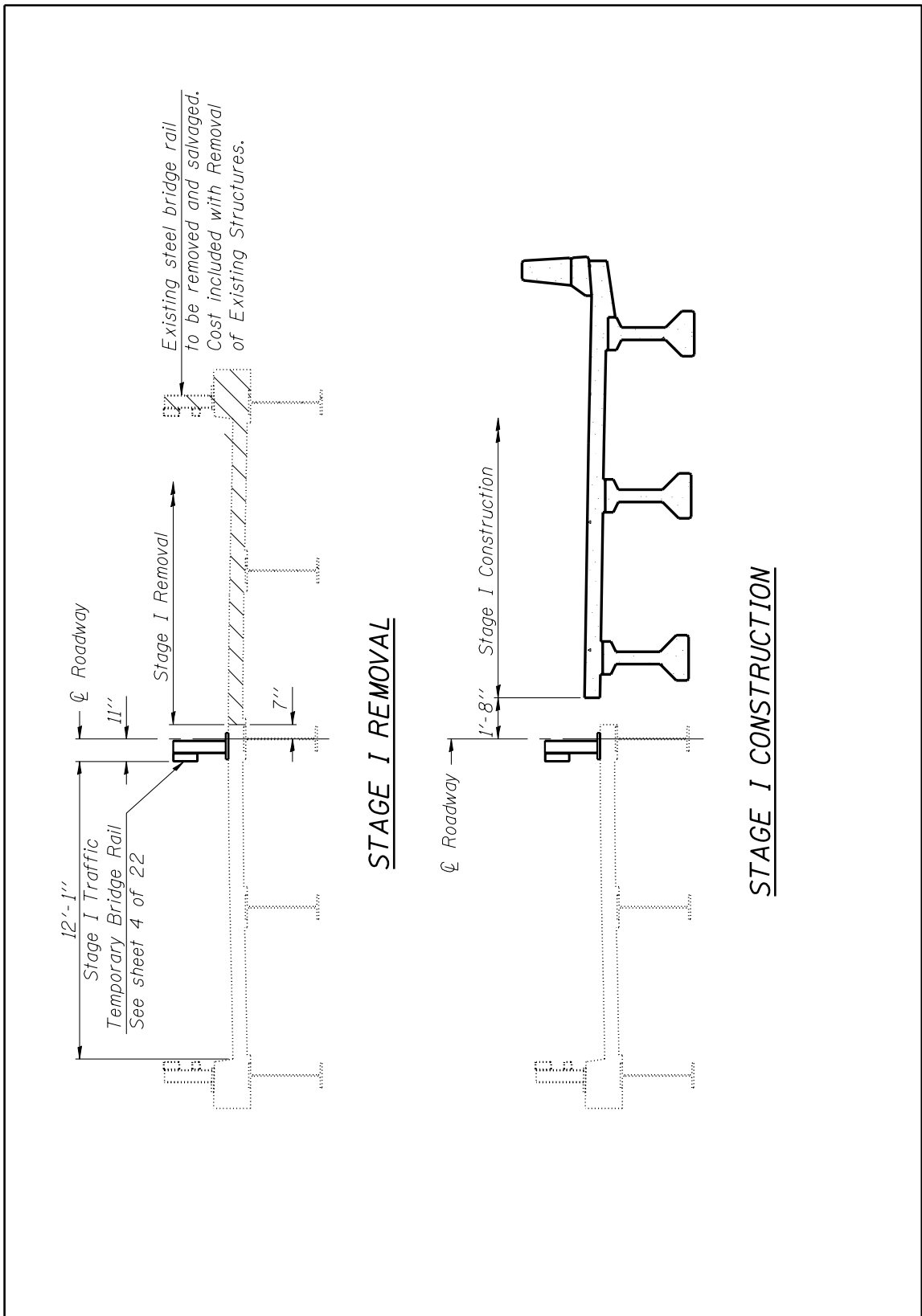

Figure 4.6.2-1. Acceptable Detailing for Stage I Removal and Construction

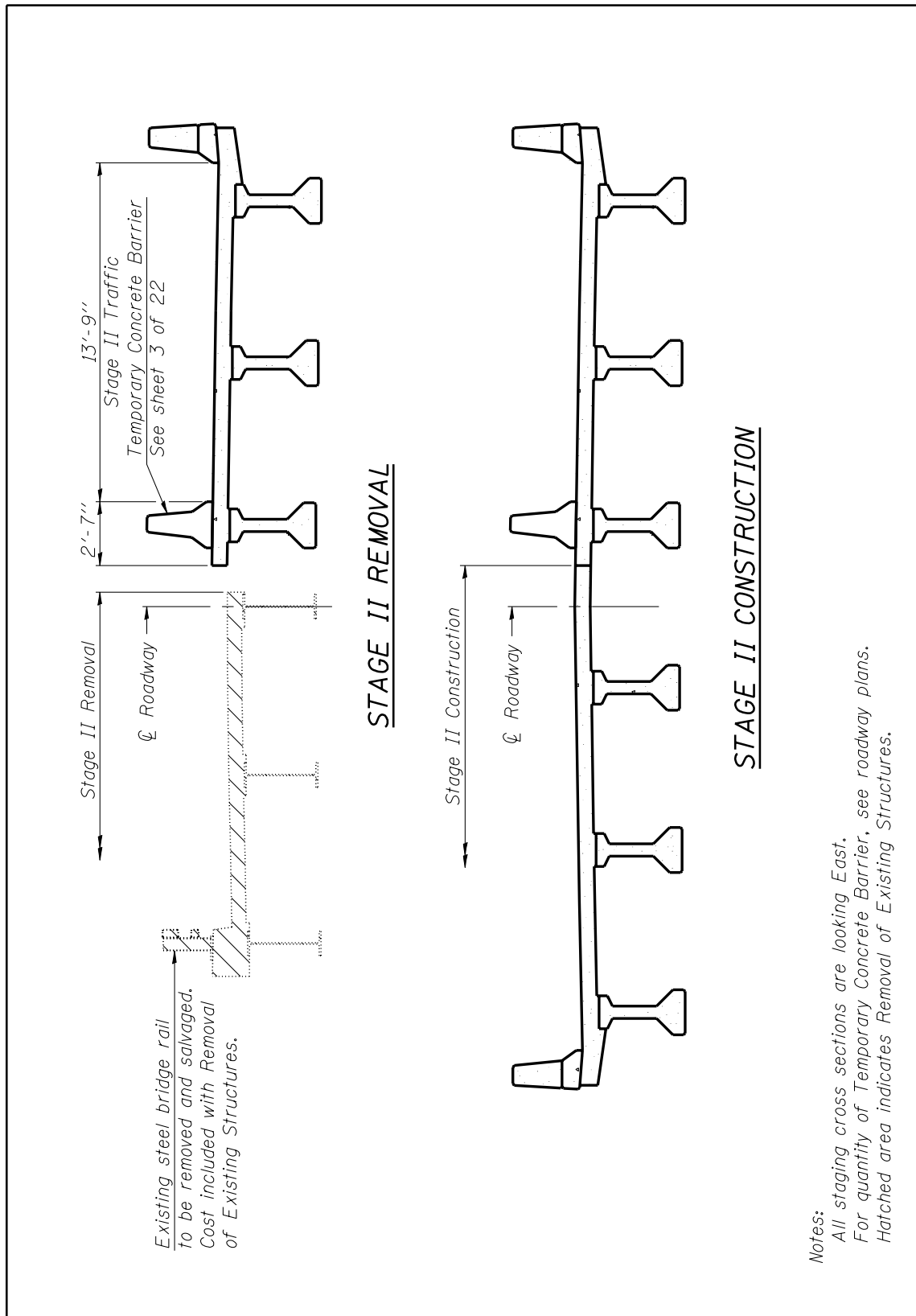

Figure 4.6.2-2. Acceptable Detailing for Stage II Removal and Construction

4.6.3 Top of Slab Elevations

- The plan for the top of slab elevation sheets should be placed on the first top of slab elevation sheet.
- Include top of slab elevation sheet(s) for the approach slabs.
- Use the text style “Br1:001scale_TOS_Elev” for the information within the tables.
- Top of slab elevations for both the bridge as well as the approach slabs shall be shown to the nearest 0.01 ft.
- Use centerline of _ Abut. in the plan and in the dead load deflection diagram with integral abutments.
- Use centerline Brg. _ Abut. in the plan and in the dead load deflection diagram with pile supported stub or semi-integral abutments
- Use centerline Brg. Pier _ in the plan and in the dead load deflection diagram with a pier if there is only a single bearing line at the pier.
- For double bearings at a pier: In the plan and in the dead load deflection diagram, call out both centerlines of bearing and the centerline of pier.
- The centerline of beams or girders should be shown using the level “Bridge_Centerline”. The centerlines are not meant to be schematic representations of the beams in this case.
- If there is a negative value (uplift) in the dead load deflection diagram, show the deflection line above the horizontal reference line. Do not show the dimension as a negative value.

4.6.4 Superstructure

- The exact number of b bars are not required to be represented in the deck cross section since these bars are called out in the plan. It is only necessary to show the first and the last bars for the bottom longitudinal reinforcement between the beams, using the callout to specify how many bars should be placed. For the top longitudinal reinforcement, it is only necessary to show a portion of the bars on each end of the section.
- Drains or scuppers need not be shown on the plan or cross section. Their locations are shown on the GP&E and are detailed elsewhere on the plans.
- Show only the parapet dimensions included on the current plan and cross section base sheets. All other parapet dimensions are on the superstructure details sheet.
- Do not show the abutment “hatch block” on the superstructure plan. The “hatch block” is the concrete poured after the superstructure is in place (for applicable jobs) and is detailed on the abutment sheets as required.
- Stationing does not generally need to be shown on the superstructure plan.
- The notes belonging on the superstructure sheet do not need to be repeated on every superstructure sheet. If the deck plan requires more than one sheet, those notes should be placed on the last superstructure sheet before the superstructure details sheet.
- For integral abutments, bar splicers are used to tie the deck to the approach. The BBS details the length of the bar splicer rods and their placement on section A-A of the diaphragm details and also on the bar splicer assembly base sheet. Dimensions do not need to be added on the superstructure plan view.
- On the superstructure cross section, do not show the shear studs. They should be detailed on the structural steel sheets.

- Lane dimensions do not need to be shown in the superstructure cross section unless they are at breaks in the cross slopes.

4.6.5 Diaphragm Details (Integral Abutment)

- On the concrete diaphragm elevation for integral abutments, do not show any wingwall details, including reinforcement. This information is included on the abutment sheets.
- In the diaphragm elevation, do not show the m bars in the corbel as sloping with the crown. These bars, in most cases, are placed level (exceptions are wide bridges or bridges with very large skews).
- Showing the approach corbel in the elevation view is unnecessary.
- In the diaphragm elevation view, do not reference section A-A in the callouts. The section cut is sufficient.

4.6.6 Diaphragm Details (Semi-Integral Abutment)

- On the diaphragm elevation, do not show any wingwall details, including reinforcement. This information is included on the abutment sheets.
- In the diaphragm elevation, do not show the m bars in the corbel as sloping with the crown. These bars, in most cases, are placed level (exceptions are wide bridges or bridges with very large skews).
- Showing the approach corbel in the elevation view is unnecessary.
- In the diaphragm elevation view, do not reference section A-A in the callouts. The section cut is sufficient.
- Either on the diaphragm details or on the superstructure sheets, include details similar to those shown in Figure 3.8.4-2 of the Bridge Manual.

4.6.7 Framing Plan (Steel, PPC I-beam or bulb T-beam)

- For structures with steel beams or girders: The framing plan is a schematic representation of the beams or girders. Beams, girders and diaphragms should be drawn as single lines using the level “Bridge_Design Steel Object” for proposed steel or “Bridge_Design Existing” for existing steel that is to remain.
- For structures with PPC I-beams or bulb T-beams: The footprint of these beams should be drawn using the level “Bridge_Design Concrete Object”.

4.6.8 Structural Steel Details

- Show web depth of plate girders in inches.
- Steel angle callouts should be listed as shown in AISC (L 6 x4 x1/4)
- For jobs using wide flange beams, the shear stud spacing can be detailed either in the plan or an elevation. If they are called out in the plan view, the studs themselves should not be shown. Only their spacing should be shown in the plan view. If the stud spacing is shown in a beam elevation, the studs should be shown.
- For jobs using plate girders, the shear studs and spacing should be shown on the girder elevation.
- The proper moment and reaction tables for LFD and LRFD jobs are located in the cell library “details.cel”. Do not add or take away definitions from these cells.

4.6.9 Abutments and Piers

- Put a north arrow on the abutment plan, but do not say which direction the reader is “looking” in the elevation view. It is understood that the view is always looking at the front face of the abutment.
- Ensure that a north arrow is placed on the pier plan.
- In the elevation view of a pier, state which direction you are looking under the view’s title.
- Dimension the bearings and piles from the centerline of roadway, or stage construction joint, if the job is staged. The dimensions shown will be from the centerline, or stage construction joint, to the exterior bearings and the exterior piles. It is not necessary to include a dimension from the end bearings or piles to the end of the abutment or pier.
- For sections through abutment or pier caps, do not show the steps beyond that section. The location of the section should be chosen such that it is representative of the substructure element being detailed.
- The anchor bolt locations should be detailed either in the abutment and pier plan view, or in a separate enlarged view.

4.6.10 Pile Base Sheets

- There are three new pile base sheets. F-HP for steel piles, F-MS for metal shell piles and F-PC for precast piles. Regardless of which one is used, it is not necessary to “X” out or remove those details that do not apply.

4.6.11 Soil Boring Logs

- Soil boring logs, rock core logs and Shelby tube tables should be included with design plans if they were made. IDOT uses the software named “gINT” to create logs for inclusion with design plans. These logs are database reports from gINT exported to dxf format. This enables inclusion into MicroStation as editable vector elements. Purchasing or using this software is not required. Logs may be included by referencing in image files (such as “tif” or “jpg”) through MicroStation’s Raster Manager. Whatever method is used, ensure that the boring logs will be legible on reduced size prints.

5 Addendums

In the event that revisions or changes to the contract plans are required after plans have been posted for bidding, but prior to the letting, an "Addendum" may be required. If an addendum is required, any element or detail that is changed shall be denoted by placing a shape using the attributes set by the level "Bridge_Addendum". Attached to this shape shall be a triangle that can be inscribed within a 1/4" radius circle and a number indicating the addendum number. This callout shall be on the level "Bridge_Dimensions and Text". In the lower right-hand corner of the sheet, the symbol with the revision number shall be followed by "Revised", "Added sheet" or "Entire sheet revised" along with the date of the revision and the initials of the person making the revision. If an entire sheet is added or revised, do not place a shape around the perimeter of the sheet. [Figure 5-1](#) is provided as an example.

<i>v₅(E)</i>	44	#9	13'-10"		
<i>v₆(E)</i>	44	#9	23'-3"	—	1
<i>v₇(E)</i>	60	#5	10'-3"	—	
<i>v₈(E)</i>	60	#5	6'-9"	—	
Drilled Shaft in Rock		Foot	30"	50	1
Drilled Shaft in Soil		Foot	36"	20	
Concrete Structures		Cu. Yd.		61.8	
Reinforcement Bars, Epoxy Coated		Pound		12710	1
Structure Excavation		Cu. Yd.		5.7	
Underwater Structure Excavation Protection-Location 1		Each		1	

Reinforcement bars designated (E) shall be epoxy coated.

PIER

STRUCTURE NO. 092-0206

SECTION	COUNTY	TOTAL SHEETS	SHEET NO.
47BR-2	VERMILION		
CONTRACT NO. 70420			
ILLINOIS	FED. AID PROJECT		



Revised 3/29/07





D.P.N.

Figure 5-1. Addendum Detailing Example

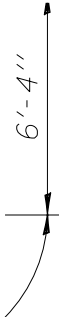
6 Construction Changes

In the event that revisions or changes to the structure contract plans are required after letting, a "Construction Change" to the contract plans is required to be prepared and distributed. If a Construction Change is required for a bridge project, any element or detail that is changed shall be denoted by placing a shape using the attributes set by the level "Bridge_Construction Change". Attached to this shape shall be a 1/4" square and a number indicating the construction change number. This callout shall be on the level "Bridge_Dimensions and Text". In the lower right-hand corner of the sheet, the symbol with the construction change number shall be followed by "Revised", "Added sheet" or "Entire sheet revised" along with the date of the revision and the initials of the person making the revision. If an entire sheet is added or revised, do not place a shape around the perimeter of the sheet. Figure 6-1 is provided as an example.



<i>v₅(E)</i>	44	#9	13'-10"		
<i>v₆(E)</i>	44	#9	23'-3"		1
<i>v₇(E)</i>	60	#5	10'-3"		
<i>v₈(E)</i>	60	#5	6'-9"		
<i>Drilled Shaft in Rock</i> 30"			<i>Foot</i>	50	1
<i>Drilled Shaft in Soil</i> 36"			<i>Foot</i>	20	
<i>Concrete Structures</i>			<i>Cu. Yd.</i>	61.8	
<i>Reinforcement Bars, Epoxy Coated</i>			<i>Pound</i>	12710	1
<i>Structure Excavation</i>			<i>Cu. Yd.</i>	5.7	
<i>Underwater Structure Excavation Protection- Location 1</i>			<i>Each</i>	1	

Reinforcement bars designated (E) shall be epoxy coated.

PIER
STRUCTURE NO. 092-0206

SECTION	COUNTY	TOTAL SHEETS	SHEET NO.
47BR-2	VERMILION		
CONTRACT NO. 70420			
ILLINOIS	FED. AID PROJECT		

1 Revised 3/29/07 D.P.N.

Figure 6-1. Construction Change Detailing Example

7 Internet Information

7.1 Web Page

The Bureau of Bridges and Structures Web Page Address is:

<http://www.dot.il.gov/bridges/brdocuments.html>

The cell libraries and additional CADD resources are available under the Bridges and Structures CADD Support link. Other pertinent information related to structures is also accessible from this page.

7.2 Subscription Service

Signing up for the Bridges and Structures Subscription Service is strongly encouraged. Notifications are sent out via e-mail whenever changes are made to any items on the BBS Documents, Manuals and Procedures Web Pages. Subscribe at: <http://www.dot.il.gov/bridges/menu.asp>

8 District and Central Office CADD Manager Contact Information

District 1	Shawn Ley	847-705-4008	Shawn.Ley@illinois.gov
District 2	James Hogenson	815-284-5490	James.Hogenson@illinois.gov
District 3	Mike Wasilewski	815-434-8952	Michael.Wasilewski@illinois.gov
District 4	Brian Keith	309-671-3395	Brian.Keith@illinois.gov
District 5	Justin Cearlock	217-466-7393	Justin.Cearlock@illinois.gov
District 6	Rhonda Laughlin	217-785-9102	Rhonda.Laughlin@illinois.gov
District 7	Mona Steffen	217-342-8313	Mona.Steffen@illinois.gov
District 8	Sandy Phillips	618-346-3231	Sandra.Phillips@illinois.gov
District 9	Barbara Lavender	618-351-5221	Barbara.Lavender@illinois.gov
Engineering Systems (BIP)	Jim Leaf	217-785-4090	Jim.Leaf@illinois.gov
Bureau of Bridges & Structures	Michael Mossman	217-782-1510	Michael.Mossman@illinois.gov