

Supplement to the

Work Site Protection Manual

Other than Highway Maintenance and Traffic Crews



Illinois Department of Transportation

February, 2001

Issue #6A

Printed by the Authority of the State of Illinois
February, 2001
2,500 Copies

Contents

Foreword	2 - 3
Traffic Control Devices	4 - 15
General Requirements	16
Locating Distances	17
Glossary, Buffer Zones	18 - 19
WZ10 Areas in Work Zone	20 - 21
WZ00 Use of One Flagger	22 - 23
General Guide for Traffic Control Cases	24 - 26
Highway Safety Information on Contract Projects	27 - 31
General Survey Highway Safety Information	32 - 35
Surveying Crew Highway Safety Information	36 - 39
Bridge Inspector Highway Safety Information	40 - 42
Drill Crew Highway Safety Information	43 - 45
Portable Scale Crew Highway Safety Information	46 - 49
Short Term Encroachment Policy - Case WZ-A	50 - 51
Work Zone Cases	52 - 109
Special Work Zone Cases	110-143

Foreword

This booklet was prepared for employees of the Illinois Department of Transportation. This is the policy for the proper application of traffic control devices for all IDOT employees working on or near open traffic lanes. These cases establish the minimum requirements for work site protection. If additional devices are needed to enhance safety, they should be added when necessary.

The proper use and most effective placement of traffic control devices is required to prevent injury to employees and the public. Planning should be part of every job so that the work can proceed in a safe, efficient, and orderly manner with a minimum of interference to motorists.

Each Case herein has been developed to meet the requirements of the "Manual on Uniform Traffic Control Devices for Streets and Highways, Part VI."

Foreword - Continued

These cases establish minimum requirements which will provide a reasonable level of safety. Application of these requirements cannot, however, guarantee the safety of every worksite. Each worker and supervisor should therefore be alert for any circumstance which could require change, including the application of additional devices. When specific operations are not covered, the traffic control should be furnished in accordance with Section 12.0 of the Safety Code, an IDOT Design Standard, or a Traffic Control Plan should be developed for the special application.

Each employee is responsible for the maintenance of devices and adjustments of traffic control to ensure the safety of the employees and the motorists. For work operations expected to be in place for more than 48 hours, a Traffic Control Plan must be developed and approved by the District Engineer or Engineer of Operators.

All employees must be in compliance with Section 24 of the "Employee Safety Code" for proper outer wear.

See "Flagger Handbook" for flagging requirements.

Traffic Control Devices

The following pages describe some of the most frequently used traffic control devices. For these devices to perform successfully they must be of good quality, their placement must be proper and their position be maintained. All devices should be periodically evaluated using the Quality Standard for Work Zone Traffic Control Devices.

Distances stated in this manual are guides. Field conditions may force adjustments to maximize visibility of flaggers and signs in some work zones. Generally, increases in distances are easily accepted whereas decreases should be seriously considered.

General Safety Requirement:

- a) When a lane is closed, the taper and buffer space should be free of equipment, trucks, and materials, when applicable.
- b) All equipment, trucks, and materials should be parked on the shoulder or downstream from the protective truck.

Drums, Barricades and Cones

Traffic cones are used to guide traffic from one lane to another and to separate work zones from the traveled way. Cones shall be a minimum height of 18 inches. Cones having a height of 28 inches shall be used on roadways having speeds of 45 mph and greater and for installations at night. At night, reflectorized cones, drums, or barricades shall be utilized. When reflectorized cones are used, workers must be present to maintain them.

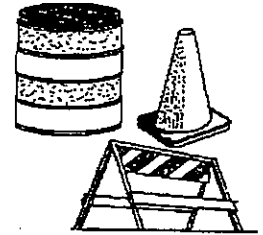

Sandbags may only be used on the lower barricade rails. Striped panels facing traffic shall not be covered. Weights of concrete, stone or other materials shall not be used.

Barricades are to be placed so that stripes slant downward toward the side on which traffic is to pass.

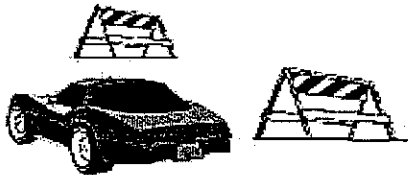

Drums or barricades may be substituted for cones at twice the spacing after the first 240 feet past the taper, i.e. after the 4th device. **When in doubt, extra channelizing devices may always be added to the minimum required in this manual.**

Work Zone Speed Limit Sign-Optional

- A 45 mph work zone speed limit sign should be used on multilane roadways with posted speed limits of either 55 mph or 65 mph where one lane is closed for more than 4 hours. It is legal for IDOT to drop the speed limit 20 mph in work zones when a work zone speed limit sign is utilized. The signs may be utilized at other locations where work zone speed reduction is desired. Use one sign with each ROAD WORK AHEAD sign.

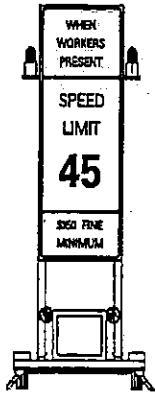

Either sign may be utilized, however the \$150 fine is only in effect for the larger three panel sign. The larger sign should be considered for use in high speed and high traffic volume areas.

- These signs should not be mounted on a vehicle. If used with a moving operation, the sign should be relocated on a frequent basis.

IDOT Std 702001, \$150 fine is in effect when sign is within 2500 feet of workers.

Work Zone Speed Limit Sign-Optional (Cont'd)

- Use of these signs is based on a worker's present condition. Whenever operations are suspended for more than one hour, the sign shall be removed, covered, or turned away from traffic.
- These signs should only be used within a standard series of warning signs. For an example of placement see Case No. WZ-41.

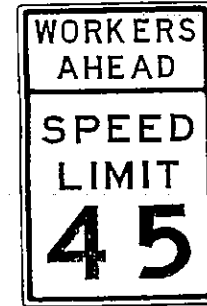

Maintenance sign, \$150 fine not in effect.

Strobe Lights

When vehicles are located on or within 15 feet of the pavement edge, strobe lights shall be utilized. This requirement includes all vehicles parked on the shoulder. Revolving lights are adequate for tractors, while non-truck mounted equipment is exempt, i.e. air compressors, asphalt kettles, etc.

Please Note: Revolving lights on existing vehicles may be utilized until the light wears out or the vehicle is replaced.

Illinois law allows the use of amber/white lights by IDOT personnel, but only when engaged in work operations.

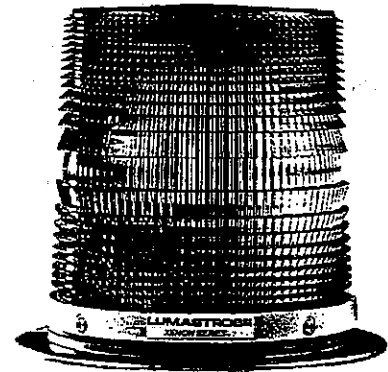

Warning Signs

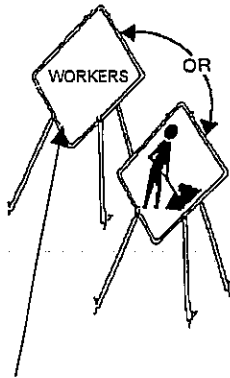

Within 20° of a vertical position

Portable signs are for use on streets and roads as a warning of the presence of workers. They are diamond-shaped panels with the word WORKERS or other suitable message in black letters on a fluorescent orange reflective background. A symbol sign may be used in place of a word-message sign.

All warning signs shall be a minimum of 48 inches by 48 inches. Signs mounted on portable stands shall be no less than 12 inches above the travel way. When warning signs are used on a paved surface, sandbags should be used to minimize movements. Tripod mounted signs shall be a minimum of 2 feet and a maximum of 10 feet from the edge of pavement or face of curb. Placement should be adjusted to field position conditions so they are readily seen by motorists. The last sign in series should be repeated 500 feet past major intersections and interchanges outside of urban areas.

Flashing Arrow Boards (AB) SHALL:

- 1) Be "aimed" at approaching traffic.
- 2) Be dimmed when used at night.
- 3) **Be used in the caution mode only for:**
 - A) Work on roadway and shoulders of two-lane two-way roads;
 - B) Work on shoulder;
 - C) When closing a shoulder;
 - D) Roadside work close to the shoulder;
 - E) When parked in a closed lane beyond the taper.
- 4) Be placed in advance of any hill crests or sharp corners that would limit visibility to approaching traffic.
- 5) Be placed at or close to the start of the lane taper.
- 6) Be disconnected from tow vehicle for periods of time more than two hours.
(Tow vehicle shall be moved so as not to be a hazard).
- 7) Have yellow panels closed when not in use.
- 8) Have yellow panels match direction of flashing arrow.

Sequential arrow displays and chevrons shall not be used.

Note: When a truck mounted AB is utilized, it replaces an AB shown on the case drawing.

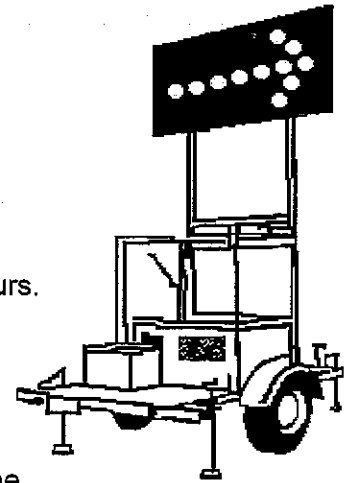

Flashing Arrow Boards (AB) Cont'd

An AB shall comply with the following requirements, any device not meeting these criteria may only be used as a supplemental device. An AB must be rectangular in shape, be of solid construction, and be finished in non-reflective black.

Type A - truck mounted 48"X24" AB mounted at least 6' high for speeds less than 45 mph.

Type B - truck or trailer mounted 60"X30" AB mounted at least 6' high for all speeds but less than 24 hour duration.

Type C - truck or trailer mounted 96"X48" AB shall have a height of 7' for all speeds and all lengths of time.

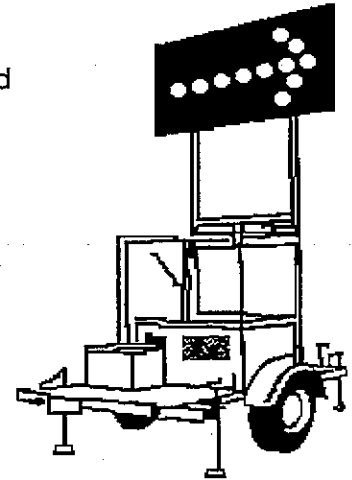

Flashing Arrow Boards – Continued

Proper Procedures:

1) Two-lane two-way highway



Panel Display

or ○○○○○○

2) Multiple Lane Roadway

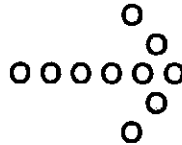

or ○○○○○○

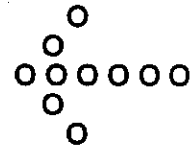

3) Merge right or left
(center lane closure)

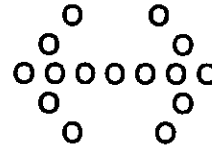

4) Caution

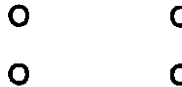

or ○○○○○○

Work During Non-Daylight Hours

Work during non daylight hours sharply reduces worker's and the motorist 's visibility of the work area.

Special attention should be given to assure maximum sign retroreflectivity and that lighting of devices is operational. Steady burn lights should be used on barricades and drums when these devices are used for delineation of the traveled way. Flashing lights are used to mark obstructions and hazards. If cones are used for non-daylight work, retroreflective collars are required. Consideration should be given to illuminating the work site. Special attention should be given to assuring that auxiliary lights/floodlights do not create a disabling glare for the motorist.

Current highway traffic control standards and details should be followed when developing a traffic control plan for a non-daylight operation.

Protective Vehicles With Truck Mounted Attenuators (TMAs)

The purpose of a protective vehicle is to protect both the workers and the motorists. When a protective vehicle is required on a case, a truck mounted attenuator and an arrow board is required unless the protective vehicle is entirely on the shoulder. TMAs shall be utilized at locations shown on the Cases.

Where the TMAs are labeled as optional, extra consideration should be given to the following:

- 1) Heavy truck volumes.
- 2) Traffic volumes and speeds.
- 3) Limited sight distance.

Please note: When a TMA is not available and one is required, the activity shall be postponed until one is available. An arrow board is not an acceptable substitute for a TMA.

Truck Mounted Attenuators (TMA)

When required on a case drawing, a TMA shall be dispatched with the crew.

The driver should exit the truck when the truck is to be stopped for more than 15 minutes.

The truck should have an actual weight no less than 11,000 pounds and no greater than 26,000 pounds. Higher weights may be used when approved by the TMA manufacturer. The truck should be positioned to allow a roll-ahead distance as follows (or other as recommended by manufacturer):

Stationary Operations - 100 feet minimum

Moving Operation - 180 feet minimum

Note: When utilized in a stationary work operation, the truck should be in neutral and the parking brakes engaged.

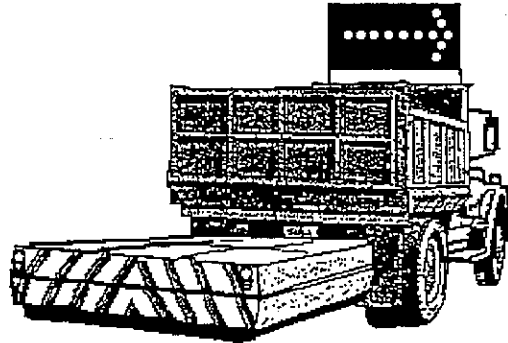

General Requirements

All traffic control devices should be placed in the order that drivers will see them, starting with the sign or device that is farthest from the work area, placing the others as the work area is approached. Removal should be done in the reverse order or under cases WZ 20, or WZ 40 for moving operations.

All vehicles, equipment, workers (except flaggers) and their **activities** are restricted at all times to one side of the pavement unless otherwise authorized by their supervisor or the applicable work zone case. At locations where all vehicles, equipment, workers or their activities are more than 15 feet from the edge of pavement, no traffic control devices are required.

WORKERS and/or FLAGGER signs are to be removed when no work is being performed for more than one hour.

If at all possible, lane closure tapers and the buffer area (see page 18) are to be kept free of any materials, equipment, or workers, except as shown herein.

Locating Distances

All devices shown on CASES should be properly placed and their position maintained. All of the dimensions shown on the CASES for the placement of devices are shown below. Distances on most roadways can easily be located by counting permanent skip-dash stripes. Since the dimensions are minimums and the stripes are spaced at 40 feet centers, adding 1/2 stripe cycle (20 ft.) when needed will keep it simple.

Distance in feet	Number of stripes*	Distance in feet/mi.	Number of Stripes*	Distance in feet/mi.	Number Of Stripes*
100	2 1/2	320	8	800	20
120	3	400	10	1000 (2/10)	25
180	4 1/2	500	12 1/2	1100	27 1/2
200	5	540 (1/10)	13 1/2	1200	30
220	5 1/2	600	15	1320	33
240	6	660	16 1/2	1500	37 1/2
260	6 1/2	720	18	1600 (3/10)	40
300	7 1/2	780	19 1/2	2000	50
				2600 (1/2)	65

*Cycles

Buffer Areas:

Buffer area as shown in WZ10, pages 20 and 21, provides recovery space for errant vehicles. Neither work activity nor storage should occur in this space.

A guide for the length of longitudinal buffer area is provided. The length may be adjusted to meet individual work site conditions.

Guide For Length of Longitudinal Buffer Area

Speed (mph)	Length (feet)
30	85
35	120
40	170
45	220
50	280
55	335
60	415
65	485

AREAS IN WORK ZONE

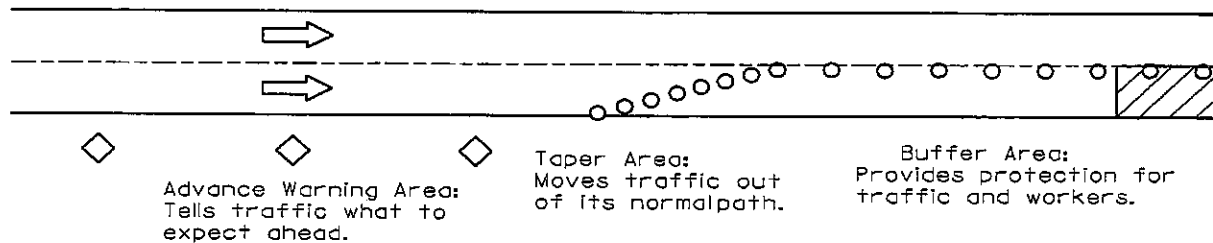

Note:
Utilize buffer area where/when possible.

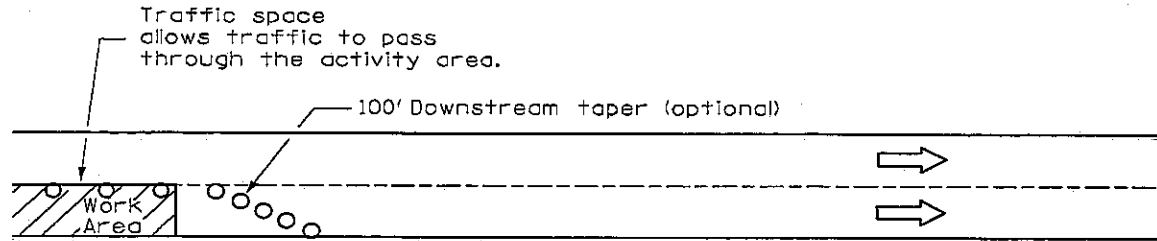

Work Area:
Is set aside for workers, equipment, and material storage.

Termination Area:
Lets traffic resume normal driving.

**USE OF 1 FLAGGER
ALL SPEEDS
STATIONARY AND
MOVING OPERATIONS**

* UNRESTRICTED SIGHT DISTANCE
45 MPH OR MORE

** UNRESTRICTED SIGHT DISTANCE
40 MPH OR LESS

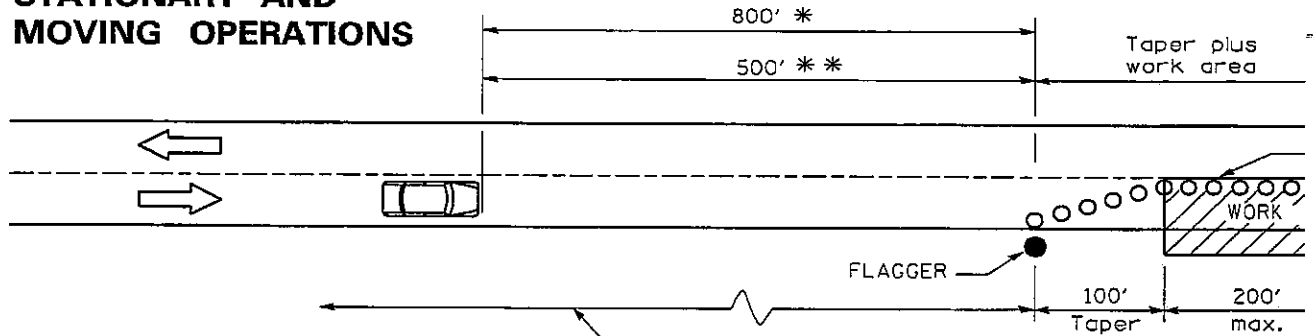

Note:
The flagger controls traffic in
the closed lane only. The other
lane operates free flow.

Advance warning signs and
other devices must be in
place in accordance with
traffic control plans in this
manual.

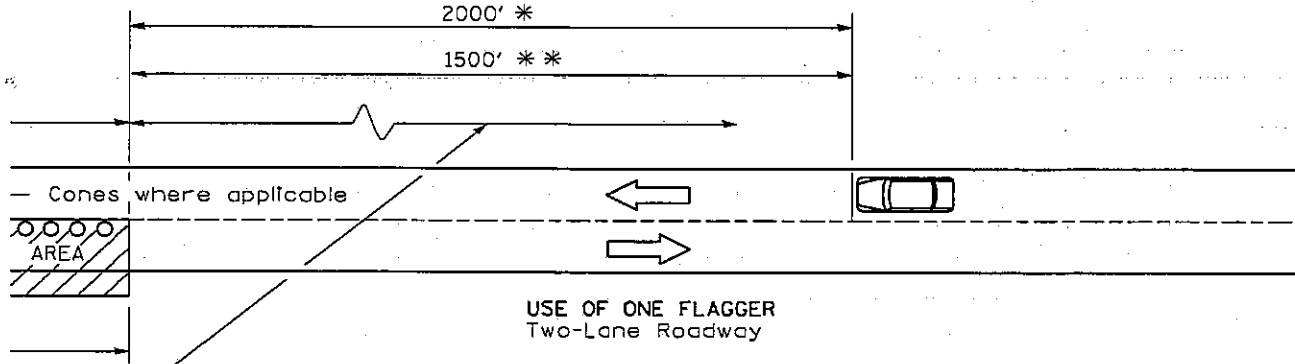

USE OF ONE FLAGGER
Two-Lane Roadway

When one lane is closed on a Two-Lane Highway, One flagger may be used when:

- A. The flagger has an unrestricted sight distance beyond the work area as indicated in the diagram.
- B. The work area does not exceed 200 feet.
- C. The traffic is not delayed more than 3 minutes.
- D. The advance warning signs are in place, when applicable.

Unless all of the above conditions are met, two flaggers shall be used.

3. Roadside and some bridge work can usually be conducted sufficiently removed from traffic. The use of strobe lights as shown on page 8 will be all that is needed. The Case Numbers shown should be reviewed to determine if they apply.
4. The index guides for work zone case number selection show most typical applications for each work activity, but may not be all inclusive. Other appropriate work zone cases or Design Standard may be utilized if the work site situations are applicable.
5. When an activity does not have a case number: a) Either the work is more than 15 feet off of the roadway or more than 2 feet beyond curb; b) A case must be selected which applies; c) An IDOT Highway Standard selected; d) A special detail must be developed.
6. Special work requires special attention. Work activities that are not conducted under normal conditions and work activities at locations that require special considerations should be planned in advance of the time workers are scheduled to make the repairs. Each worker and supervisor should be alert for any circumstance which would require change. Major deviations from the Case Number selection index should be with the approval of the supervisor.

Highway Safety Information on Contract Projects

Highway Safety Information on Contract Projects:

When State work forces are exposed to the hazards of traffic, **the Engineer shall ensure their safety by providing appropriate traffic control and protection.** On projects with contracts let and the Contractor is on the project, most traffic control should be provided by the Contractor with Standards included in the contract. Many times the Contractor will be required to setup Std. 701301, which allows for short time operations. Infrequently, IDOT personnel working on a project may do a layout or inspection outside the limits of the Contractor's traffic control and protection. **If this cannot be done safely by utilizing the "Short Term Encroachment Policy", Case WZ-A on page 51, the contractor should be required to provide the proper traffic control and furnish signs, channelizing devices, flaggers, and other necessary traffic control items as directed by the Engineer.** This work should be paid at the contract unit price for that standard or by Article 109.04 of the Standard Specifications for Road and Bridge Construction. For patching contractors on multilane roadways, the Contractor may be required to set up his traffic control 2 days early so that IDOT personnel may mark patches.

When personnel, surveyors, or inspectors are on the roadway, advance warning signs shall be used, except when the "Short Term Encroachment Policy" on page 51 is being utilized. SURVEY CREW warning signs may be substituted for WORKER signs, as appropriate, to better advise motorists of the hazard they approach. Otherwise, signs and signing requirements should be as required under the appropriate Standards or Work Zone Case.

Contract Projects Cont'd.:

The taking of measurements in a traffic lane should be performed as quickly as possible. Standing in or adjacent to an open traffic lane should be avoided while discussing the work or while transmitting or recording readings.

Exposures of personnel to peak traffic volumes should be avoided by scheduling the working hours of personnel to be near the roadway during periods of off-peak traffic conditions, when possible.

Vehicles of employees are to be legally parked 15 feet or more from the edge of the traveled way and in the same direction of traffic. Vehicles parked within 15 feet of the pavement edge must be in the same direction of traffic and have their strobe lights operating. All vehicles shall be parked in the direction of the traffic on the same side of the pavement.

Contract Projects Index Guide:

Index Guide for when the Contractor is not able to supply the Traffic Control.

Marking Patches and other on pavement investigations:

Multilane	High Traffic Volumes >20,000 ADT	WZ 40, 41, 42, 44, 46, 47
Multilane	Low Traffic Volumes <20,000 ADT	WZ A, 40, 41, 42, 44, 46, 47, S4
Two Lane	Traffic Volumes >5,000 ADT	WZ 20, 24, S1, S2, S3
Two Lane	Traffic Volumes <5000 ADT	WZ 20, 24,30, S1, S2, S3

Layout and Staking with Instrument on Pavement, and Chaining Along Centerline:

Multilane	WZ 40, 41, 42, 44, 46, 47, 48, 49, 60, 62, 92	
Two Lane	High Traffic Volumes >5,000 ADT	WZ 20, 22, 24, S2
	Low Traffic Volumes <5,000 ADT	WZ 20, 22, 24, 30, S2, S5

Profilographing:

Two Lane	WZ 22, 24
----------	-----------

Cross Sectioning (No Instrument on Pavement):

Multilane	WZ A, 4, 6, 40, 46, 47, 48, 49, 60, 62, S4
Two Lane	WZ A, 4, 6, 20, 22, 24, 30, S1, S2, S3
Intersections	WZ 91, 94

Contract Projects Index Guide Cont'd.:

Walk On /Walk Off Miscellaneous Inspections:

The Short Term Encroachment Policy on page 51 may be used where it is safe / applicable.

Multilane: WZ A, 40, 46, 47, 48, 49, S4

Two Lane: WZ A, 20, 24, 30, S1, S2, S3

Day Labor Type Operations and Other Similar Operations:

Unloading Equipment and Supplies: WZ 3, 4, 20.

Shoulder Rock Projects: WZ 22.

Beam Changes / Straightening and Bridge: Multilane WZ 41, 44.

Joint Work – Daytime Operations: Two Lane WZ 21

Bump Milling Operations: Multilane WZ 46, 49.

Two Lane WZ 20, 22, 24

Joint Cutting:

This Work may be done utilizing the following Work Zone Cases by making a few minor adjustments. On multilane roadways when the saw encroaches into an open lane, the channelizing devices shall be moved about 4 feet into the open lane to allow for the encroachment. The taper shall be at the same rate as the taper that closed the lane. The flagger, when required, shall stay behind the channeling devices. The channelizing devices shall be moved back to their original position as soon as possible.

One side of the highway will be done at a time.

Multilane: WZ 41, 42, 44, 47, 48, 49.

Two lane: WZ 20, 22, 24.

General Survey Highway Safety Information

General Survey Safety Information:

1. It is each employee's responsibility to work in a safe manner. Safety is not to be compromised.
2. Peak traffic volumes should be avoided by scheduling working hours to be near the roadway during periods of off-peak traffic conditions, when possible.
3. Vehicles should be legally parked facing the same direction as traffic using the adjacent lane 15 feet from the edge of the traveled way in rural areas. In urban areas, vehicles should be parked in parking lanes. Vehicles parked within 15 feet of the pavement edge must have their strobe lights operating, unless in a marked parking lane. All vehicles shall be parked on the same side of the pavement in the same direction as traffic flow.
4. **Do:**
 - a) Minimize workers and time on pavement.
 - b) Plan an escape route.
 - c) Look both directions before walking onto the shoulder and the pavement.
 - d) Transmit and record data and discuss work away from open lanes and the area adjacent to an open lane.
 - e) Avoid turning your back on traffic!

General Survey Cont'd.:

5. Two Lane Roadways:

- a) Use strobe lights on vehicle when driving slower than normal speed, and when stopped.
- b) Minimize stopping vehicle on shoulder. When possible, park at entrances.
- c) When possible, avoid parking on narrow shoulder or in "no-passing zones."
- d) Case WZ-A and WZ 30 may be utilized where applicable.

6. Multilane Roadways:

- a) Drive on shoulder with strobe lights on when traveling significantly slower than normal speeds and when parked.
- b) Park on the outside or median shoulder, whichever is closer to the work.
- c) Make sure vehicle is parked on the shoulder of the lanes in which you are working. Do not cross the median and work in the opposite direction lanes without moving the vehicle.
- d) Stop / park vehicle as far as possible off the edge of the pavement.
- e) Minimize walking / running across traffic lanes.

Workers should enter onto the pavement only during appropriate gaps in traffic in accordance with the "Short Term Encroachment Policy", Case WZ-A. If the operation requires workers to remain in a traffic lane, the lane must be closed with proper traffic control signs and devices.

General Survey Index Guide:

1. Field Checks, Inspections, Meetings and Notes, Final Inspections, Hydraulic Checks, Misc. Inspections, and Patching, Pickup and Road Condition Surveys:

Multilane Roadways:	WZ A, 4, 5, 6, 40, 46, 47, 49, 60, 62, S4
Two Lane Roadways >5000 ADT:	WZ A, 4, 5, 6, 20, 24, S1, S2, S3
Two Lane Roadways <5,000 ADT:	WZ A, 4, 5, 6, 20, 24, 30, S1, S2, S3

2. Short Intermittent periods of time on the pavement, i.e. Traffic Counter Tubes:

Multilane Roadways:	WZ A, 40, 46, 47, 60
Two Lane Roadways:	WZ A, 24, 30
Intersections:	WZ A, 91, 94

3. Surveys in vehicle, driving slower than prevailing speed:

Flashing strobe lights on vehicle.

4. Data Collection / Maintenance of Permanent Counter Stations and Installation of Counter Stations on pavement:

Multilane Roadways:	WZ 40, 41, 42, 46, 47, 48, 51
Two Lane Roadways:	WZ 20, 21, 30

5. Bridge Deck Soundings:

Multilane Roadways:	WZ 40, 41, 46, 47, 48, 49
Two Lane Roadways:	WZ 20, 24, 30

Surveying Crew Highway Safety Information

Surveying Crew Safety Information:

1. **The employee placed in charge of the survey crew shall have the primary responsibility for ensuring that traffic control is established.**
2. It is each employee's responsibility to work in a safe manner and to provide a safe environment for the crew and the traveling public. Safety is not to be compromised.
3. Crew chief shall discuss with his supervisor the use of additional devices when increased traffic volume necessitates, including, but not limited to: additional flaggers, lane closures, use of spotters to watch for hazardous conditions and to warn the crew.
4. Offset surveying procedures should be used whenever possible. Actual time on the roadway should be kept to a minimum.
5. Peak traffic volumes should be avoided by scheduling the working hours of personnel to be near the roadway during off-peak traffic periods.
6. Operations other than centerline chaining require frequent short duration movements on / off the roadway, require the use of flaggers as required by the appropriate case.
7. SURVEY CREW warning signs may be substituted for WORKER signs so that motorists are more aware of the hazard they approach.
8. Vehicles of employees should be legally parked 15 feet from the edge of the traveled way in the direction of traffic flow. Vehicles parked within 15 feet of the pavement edge must have their strobe lights operating. All vehicles shall be parked on the same side of the pavement and in the direction of traffic flow.

Surveying Crew Cont'd.:

9. Do:

- a) **Minimize workers on pavement.**
- b) **Plan an escape route.**
- c) **Always look both directions before walking onto the shoulder / pavement.**
- d) Discuss work, and transmit and record data away from open lanes and the area adjacent to an open lane.
- e) If available, someone should serve as a "look out" / "spotter" to watch for hazardous traffic conditions to warn co-workers.
- f) When possible, a minimum of two employees should be present when working on high volume roadways.
- g) Avoid turning your back on traffic.

10. Do Not:

- a) Stand directly behind or in front of a vehicle.

11. Two Lane Roadways:

- a) Use strobe lights on vehicle when driving slower than normal speed, and when stopped.
- b) Minimize stopping vehicle on shoulder. When possible, park at entrances.
- c) When possible, avoid parking on narrow shoulder or in "no-passing zones."
- d) The "Short Term Encroachment Policy", Case WZ A and WZ 30 may be utilized where applicable.

Surveying Crew Cont'd.:

12. Multilane Roadways:

- a) Drive on shoulder with strobe lights on when traveling significantly slower than normal speeds.
- b) Park the same direction as adjacent traffic flow on the outside or median shoulder, whichever is closer to the work.
- c) Park vehicle, with strobe lights on, on the shoulder of the lane in which you are working. Do not cross the median / work in the opposite direction lanes without moving the vehicle.
- d) Stop / park vehicle as far as possible off the edge of the pavement.
- e) Minimize walking / running across traffic lanes.
- f) Workers should enter onto the pavement only during appropriate gaps in traffic in accordance with the "Short Term Encroachment Policy", Case WZ A. If the operation requires workers to remain in a traffic lane, the lane must be closed with proper traffic control signs and devices.

13. INDEX GUIDE - Layout & Staking With Instrument on the Pavement and Chaining

Along the Centerline:

a) Multilane Roadways:	WZ 40, 41, 42, 44, 46, 47, 48, 49, 60, 62, 92
b) Two Lane Roadways	WZ 20, 22, 24, 30, S2, S5

14. INDEX GUIDE - Field Surveys Without an Instrument on the Pavement:

a) Multilane Roadways:	WZ A, 4, 6, 40, 46, 47, 48, 49, 60, 62, S4
b) Two Lane Roadways	WZ A, 4, 6, 20, 22, 24, 30, S1, S2, S3
c) Intersections	WZ A, 91, 94

Bridge Inspector Highway Safety Information

Bridge Inspector Safety Guidelines:

1. **The supervisor assigned for the inspection crew is responsible for ensuring that traffic control is properly established and maintained.** The guidelines in this section are “minimums” and should be supplemented as needed to minimize hazardous conditions, such as poor sight distance, poor weather conditions, higher traffic speeds, higher traffic volumes, sharp curves, tight clearances , etc. **Extra care is required while working on bridges, because of the lack of an escape route. When in doubt, add additional traffic control.** In no case can any of the requirements be reduced or eliminated.
2. Peak traffic volumes should be avoided by scheduling working hours on the bridge deck during periods of off-peak traffic conditions.
3. **Do:**
 - a) Utilize “Short Term Encroachments Policy”, Case WZ A where applicable. **Minimize workers and time on the pavement and the bridge deck.**
 - b) **Plan an escape route.**
 - c) **Look both directions before walking onto the shoulder / traffic lanes.**
 - d) Discuss work, and transmit and record data away from open lanes. Minimize the use of the area adjacent to an open lane to discuss work and record data, as much as possible.
 - e) Stop / park vehicle as far as practical off the edge of the pavement.
 - f) **Avoid turning your back on traffic.**

Bridge Inspector Index Guide:

As a minimum, the following cases may be utilized for daylight inspections that will last 60 minutes or less:

Case I: ADT < 2500 / Lane:

- a) Utilize "Short Term Encroachment Policy WZ A/ WZ 30, page 51, and
- b) Two person inspection team so they can assist each other in warning of approaching traffic.

Case II: ADT > 2500 < 5000 / Lane:

- a) Two person inspection team so they can assist each other in warning of approaching traffic, and
- c) Vehicle parked in a visible location with strobe lights, and
- d) Two signs in each direction for 3 lane roadways or less and undivided multilane roadways. (See WZ B1), or
- e) Four signs in each direction for more than 3 lanes; divided. (See WZ B2 & 3)

Case III: ADT > 5000 / Lane:

Utilize Cases required for work lasting more than 60 minutes, listed below.

The following cases shall be utilized for daylight inspections that will last more than 60 minutes:

2Lane WZ 4, 5, 6, 20, 21, 24, 30

Multilane WZ 4, 5, 6, 40, 41, 42, 44, 46, 47, 49, 50, 51

Drill Crew Highway Safety Information

Drill Crew Safety Guidelines:

Safety:

- 1. The drill site and crew shall be protected at all times with the proper signs and flaggers in accordance with this Manual.** A copy of this Manual should be in each vehicle. **All personnel should be aware of which Traffic Control Case is being used, what is involved with the setup, and who is in charge of the traffic control.** Any vehicle within the limits of the traffic control "work area" and within 15 feet of the pavement edge will have strobe lights operating at all times.
- 2. Safety is the responsibility of all members of the drill crew.** Working together in close communication with each other is imperative. Any unsafe or questionable condition shall be called to the attention of the crew chief and discussed with other crew members and corrected.
- 3. Only trained flaggers are allowed to flag.**

Drill Crew Cont'd.:

Index Guide for Drilling Crew Employees:

Operation & Time Required	2 Lane Roadway	Multilane Roadway	Intersections	Ramps
Pavement Core <60 minutes	WZ 3, 4, 20, 22	WZ 4, 5, 40, 41 46, 47, 48, 49, 50, 51	WZ 91, 92, 93, 94, 95	WZ 60, 62
Soil Boring <60 minutes	WZ 3, 4, 20, 22	WZ 4, 5, 40, 41 46, 47, 48, 49, 50, 51	WZ 92, 93	WZ 60, 62
Soil Boring >60 minutes	WZ 6, 21, 22	WZ 41, 42, 46, 47 48, 49, 50, 51	WZ 92, 93	WZ 61, 62
Structure Borings	WZ 21	WZ 41, 42		

Applicable IDOT Design Standard may also be utilized.

Portable Scale Crew Highway Safety Information

Portable Scale Crew Safety Guidelines:

1. Safety is the responsibility of all members of the portable weigh scale crew. Working together in close communication with each other is imperative. Any unsafe or questionable condition shall be called to the attention of the supervisor and discussed with other crew members and corrected. Safety is not to be compromised.
2. The guidelines in this section are minimums and should be supplemented as needed to minimize hazardous conditions.
3. **Do:**
 - a) Spend least time possible in the area between / around the trucks.
 - b) Spend least time possible crossing between where trucks are moving / parking.
 - c) Look both directions when moving in the area of the trucks.
 - d) Avoid turning their backs to traffic.
 - e) Avoid standing directly in front of or in back of vehicles.
 - f) Discuss work, and transmit and record data in a safe location.
 - g) Plan an escape route.

Portable Scale Guidelines Cont'd:

4. Oncoming traffic should have a clear, unobstructed view for at least 1,500 feet prior to the truck weighing zone. This may be reduced in areas of lower posted speed limits.
5. Selecting sites for scale operation:
 - a) Interstate Rest Areas should not be used during tourist season, between May 16 through September 15. When rest areas are utilized, caution must be used to prevent blockage of entry ramps so that access is always provided to the motorists.
 - b) It is highly desirable to vary the hours of operation of the scales. During periods of darkness, only well lit locations should be utilized. It may be necessary to supplement the lights with portable or fixed lighting.
 - c) New locations for portable scales are considered on a case by case basis. Contact supervisor for the correct method of requesting such a location.
6. Weighing operations should not be conducted when conditions are such that safety would be compromised. **The surface of scales should be dry to prevent slippage of truck tires.**
Weighing of trucks should not be done under the following conditions:
 - a) **Wet conditions. (at the discretion of the Illinois State Police)**
 - b) **Ground fog, this severely restricts visibility and makes the scales unstable.**
 - c) **Blowing snow.**
 - d) **Ice.**

Portable Scale Guidelines Cont'd:

7. The scale crew has the following signs and equipment:
 - a) TRUCK SCALES AHEAD sign - [48" diamond, black letters on yellow]
 - b) ALL TRUCKS MUST WEIGHT - [48" square, black letters on white]
 - c) TRUCKS USE RIGHT LANE SCALES AHEAD [48" square black letters on white]
 - d) CARS USE LEFT LANE - [48" square, black letters on white. "LEFT" TRUCKS USE RIGHT LANE - and "RIGHT" words are interchangeable]
 - e) TRUCK SCALES - [48" square, black letters on white, arrow is reversible]
—————>(arrow)
 - f) Sign stands
 - g) 28" narrow profile high visibility cones.
 - h) Reflective cone collars.
 - i) Fire extinguisher – 10 pound dry chemical, A-B-C Fires.
 - j) Red flags
 - k) Operable flashlight.
8. **INDEX FOR PORTABLE SCALE CASES:**
 - a) Multilane Roadways: WZ W1, W2, W3
 - b) 2 Lane Roadways: WZ W4, W5, W6

CASE WZ - A

Short Term Encroachment Policy

CASE WZ – A

Short Term Encroachments on Pavement With Adequate Site Distance:

A. No attempts shall be made to stop, slow, or direct traffic into another lane except by a properly equipped flagger with proper warning signs in place.

B. May be performed without a flagger, provided all vehicles are completely off traveled lanes and as far off the edge of the pavement as practical.

- 1) Each task must be performed with extreme care.
- 2) The amount of time the workers are on the pavement shall be minimized.
- 3) Workers shall enter onto the pavement only during appropriate gaps in traffic.
- 4) If workers must remain in traffic lane and appropriate gaps do not exist, the lane must be closed with proper traffic control signs and devices.
- 5) When possible, work on the same side of road as the vehicle.
- 6) Vehicles shall have strobe lights on.**
- 7) Multi-lane roadways; at slow speeds, drive on shoulder with strobe lights on.

C. This provision does not apply when marking pavement patches, bridge deck patches, or survey crew work with instrument on the pavement.

D. When it is necessary for vehicle to stop on the roadway, traffic control shall be in accordance with the proper case.

E. Full lane closure should be considered when work at one location would exceed one hour.

Shoulders

**ALL SPEEDS
TWO-LANE & MULTILANE
SHOULDER WORK WITH
MINOR ENCROACHMENT
60 MINUTES OR LESS
SIGHT DISTANCE OF 1000' TO
APPROACHING TRAFFIC REQUIRED**

**WZ 03
DAY AND NIGHT**

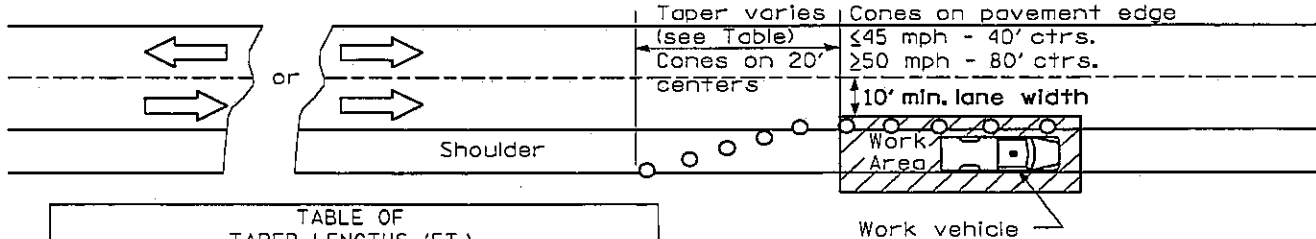

TABLE OF TAPER LENGTHS (FT.)					
SPEED MPH	SHOULDER WIDTH (FT.)				
	2	4	6	8	10
65	45	90	130	175	220
55	40	75	110	150	185
45	30	60	90	120	150
40	20	35	55	70	90
35	15	30	40	55	70
30	10	20	30	40	50

When workers encroach onto roadway, a protective vehicle (see page 14) is required. All vehicles shall operate strobe lights.

**THIS CASE IS ONLY ALLOWED
DURING NON-PEAK TRAFFIC.**

**ALL SPEEDS
TWO-LANE AND MULTILANE
LESS THAN 60 MINUTES
SHOULDER WORK**

**WZ 04
DAY OR NIGHT**

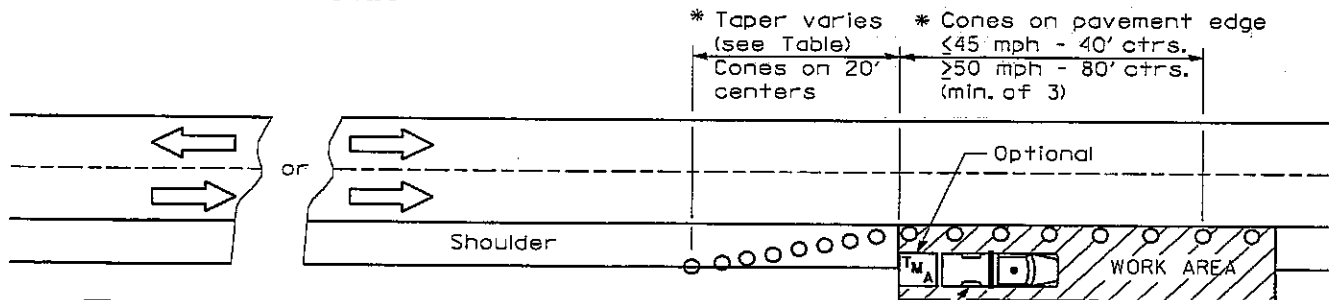
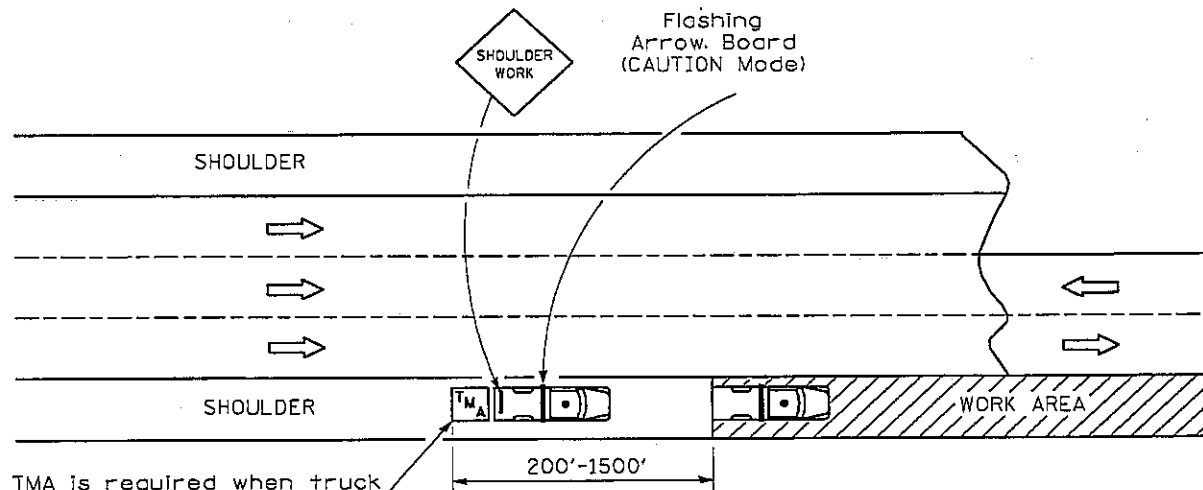

TABLE OF TAPER LENGTHS (FT.)					
SPEED MPH	SHOULDER WIDTH (FT.)				
	2	4	6	8	10
65	45	90	130	175	220
55	40	75	110	150	185
45	30	60	90	120	150
40	20	35	55	70	90
35	15	30	40	55	70
30	10	20	30	40	50

INTERMITTENT/MOVING OPERATION SHOULDER WORK

WZ 05



TMA is required when truck encroaches onto roadway.

All vehicles operating strobe lights.

ALL SPEEDS TWO-LANE AND MULTILANE 60 MINUTES OR MORE SHOULDER WORK

For work more than 2 hours
an Arrow board is required.

TABLE OF TAPER LENGTHS (FT.)					
SPEED MPH	SHOULDER WIDTH (FT.)				
	2	4	6	8	10
65	45	90	130	175	220
55	40	75	110	150	185
45	30	60	90	120	150
40	20	35	55	70	90
35	15	30	40	55	70
30	10	20	30	40	50

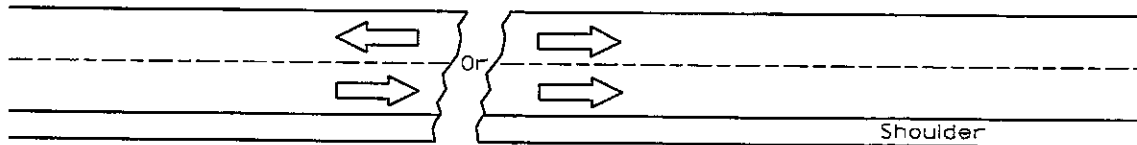
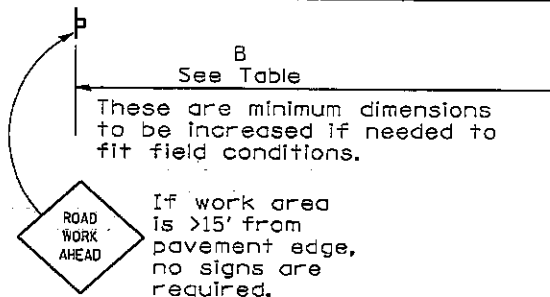
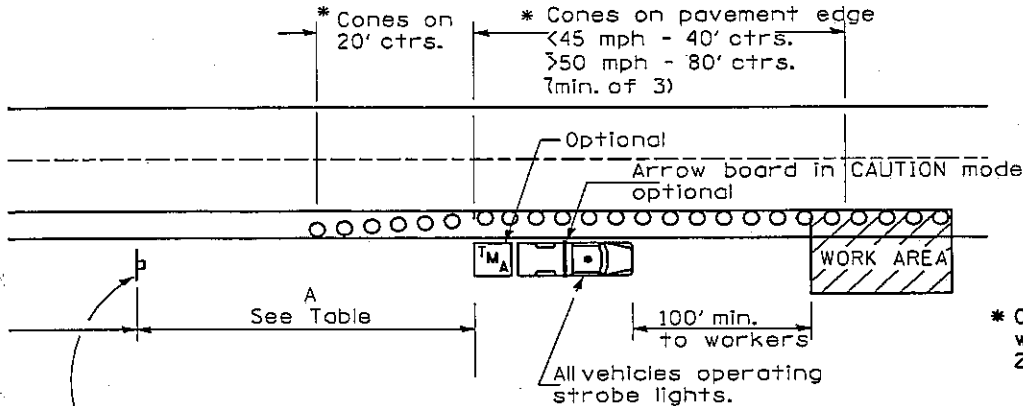

TABLE OF SIGN SPACING		
SPEED MPH	LENGTH A	LENGTH B
65	1,000'	1,600'
55-60	500'	500'
45-50	350'	350'
<40	200'	200'



WZ 06

Arrow board in CAUTION mode, required when sight distance is not available.



* Cones required when working within 2 ft. of pavement.

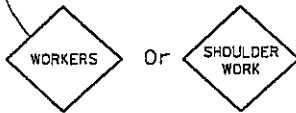

Signs required on both sides of multilane divided highway when median is > 10'.

**ALL SPEEDS
2 LANE 2 WAY
OFF ROAD MOVING OPERATION
NO TIME LIMIT**

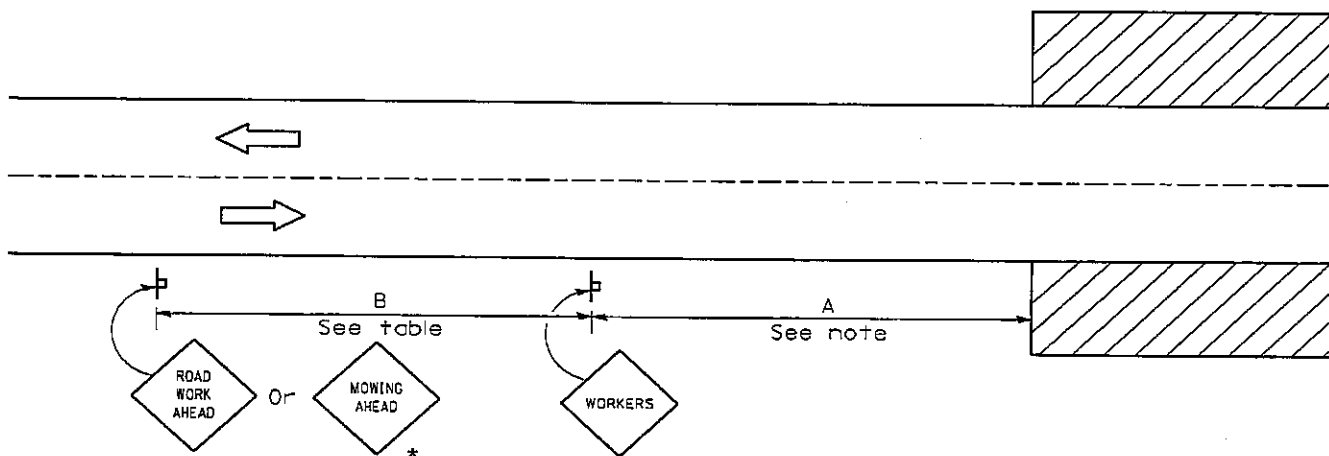

* May be used for maintenance
mowing operations

WZ 07a

If work area is more than 15 ft. from pavement edge, no signs are required.

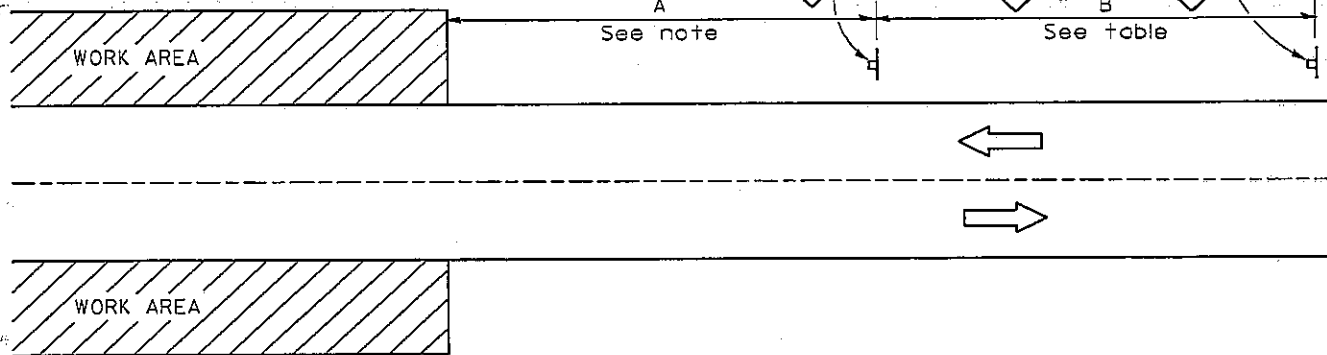
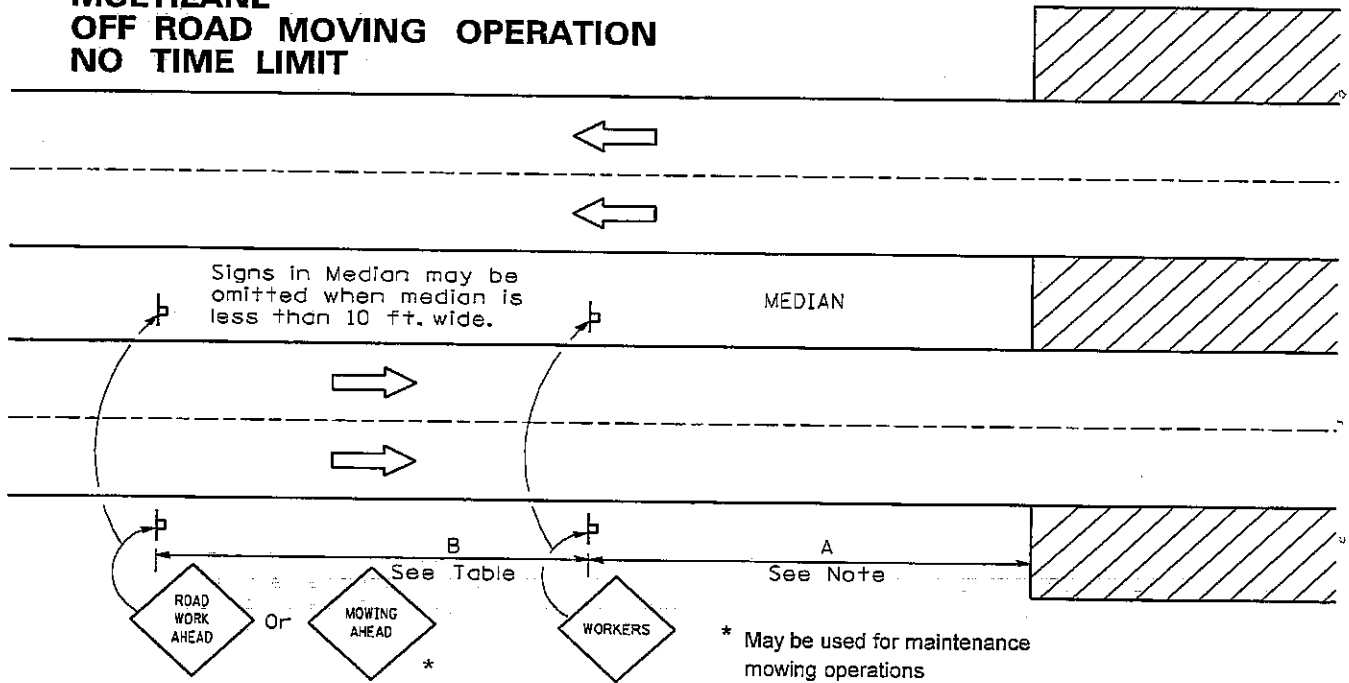

TABLE OF SIGN SPACING		
SPEED MPH	LENGTH	
	A	B
55	500'	500'
45-50	350'	350'
≤40	200'	200'

Note:
Minimum distance is A from table at the Start of the Operation. Maximum distance is not to exceed one half the length required for one normal day's operation (4 miles maximum).

**ALL SPEEDS
MULTILANE
OFF ROAD MOVING OPERATION
NO TIME LIMIT**



If work area is more than 15 ft. from pavement edge, no signs are required.

WZ 07b

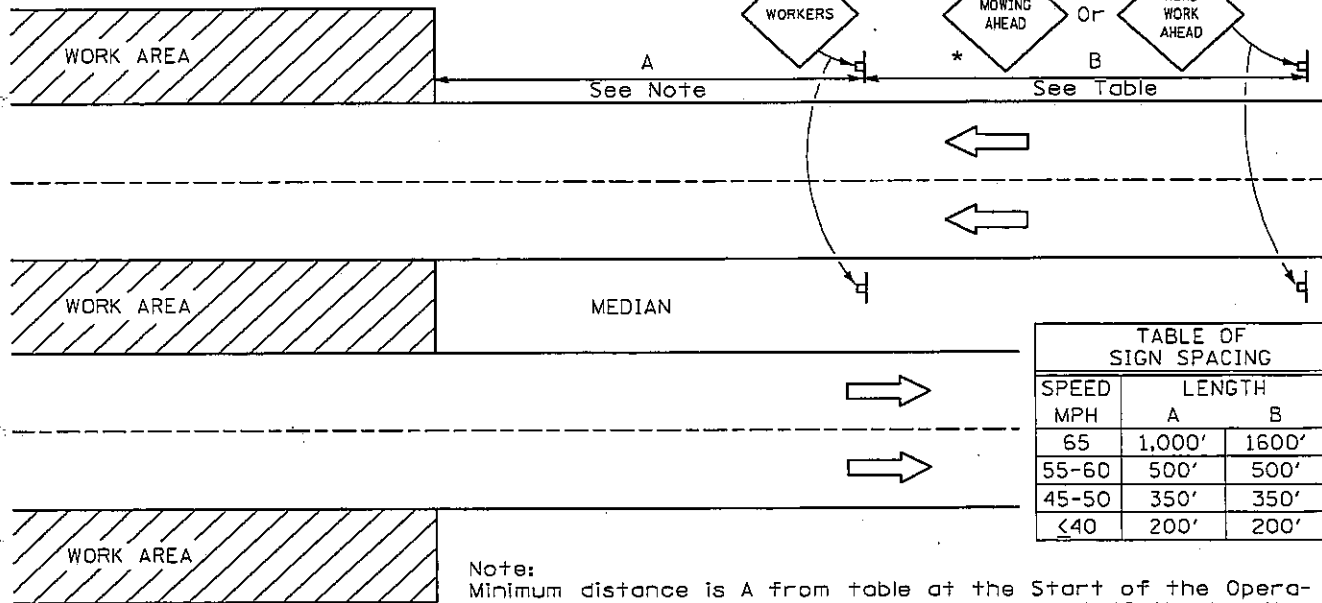

Note:
Minimum distance is A from table at the Start of the Operation. Maximum distance is not to exceed one half the length required for one normal day's operation (4 miles maximum).

2-Lane 2-Way

WZ 20

ALL SPEEDS LESS THAN 60 MINUTES

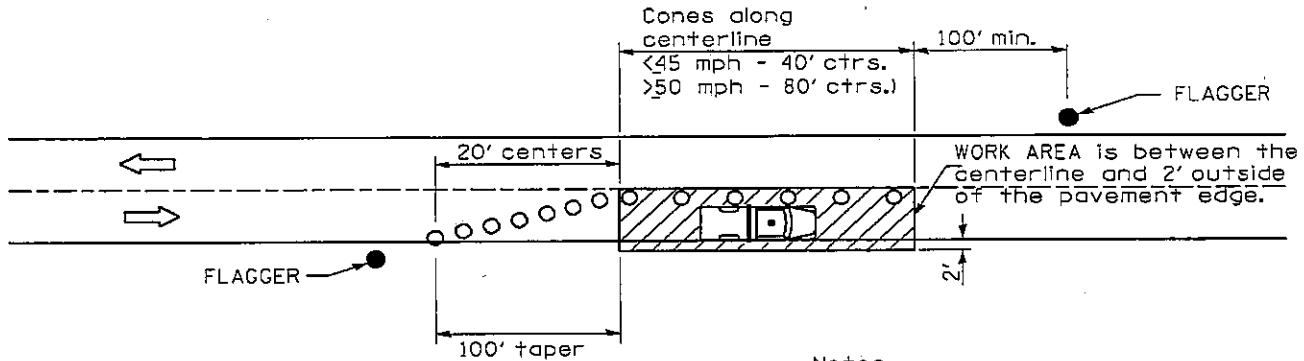

All vehicles operating
strobe lights.

Adequate sight distance required
otherwise utilize CASE WZ-21.

Notes:

Cones required after 30 minutes.

See page 23 for criteria
for utilizing one flagger.

**ALL SPEEDS
NON-MOVING OPERATION
NO TIME LIMIT**

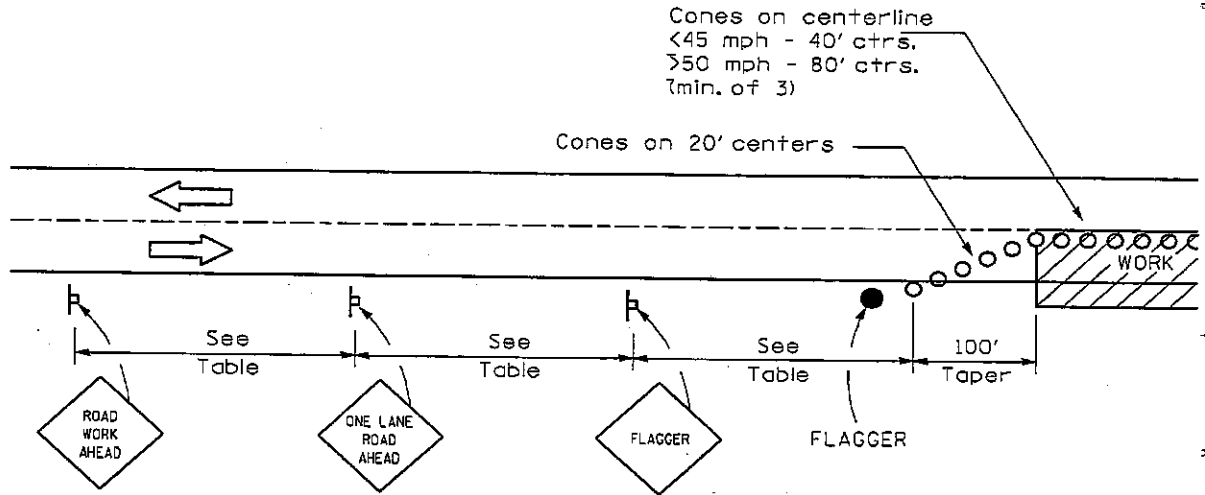

WZ 21

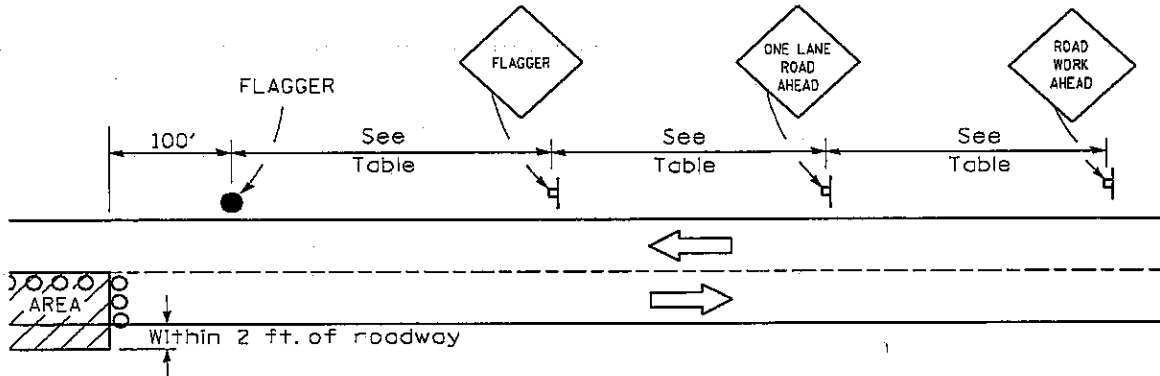

See page 23 for criteria for utilizing one flagger. All vehicles operating strobe lights.

TABLE OF SIGN SPACING	
SPEED MPH	LENGTH
55	500'
45-50	350'
≤40	200'

**ALL SPEEDS
MOVING OPERATION
NO TIME LIMIT**

Flaggers used for moving operations is dependent on the travel speed. If the work operation moves too fast for flaggers, the flaggers may be omitted and the FLAGGER signs shall be replaced with WORKER signs. In lieu of flaggers, a protective vehicle with a TMA and an arrow board in CAUTION mode shall be used in advance of the work area.

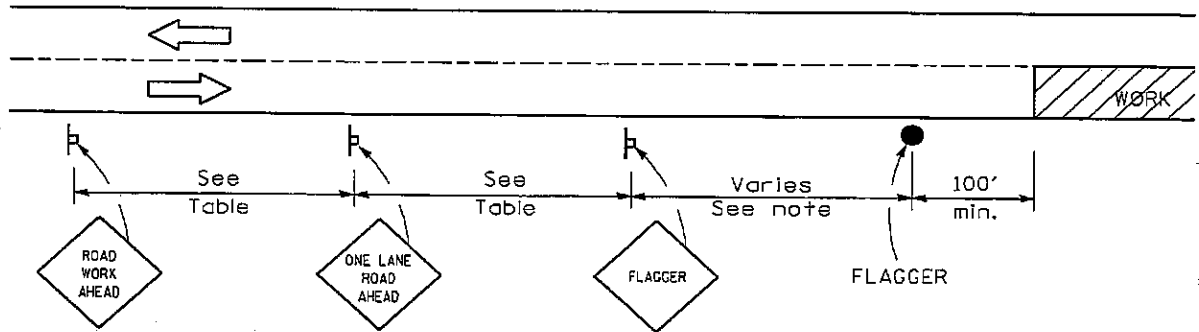

If work operation exceeds 2 miles per 1/2 day, utilize detail WZ24.

All vehicles operating strobe lights.

WZ 22

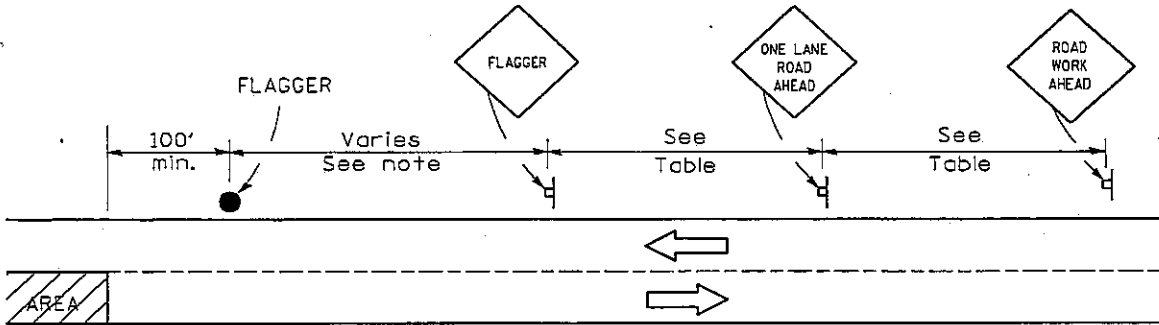

See Flagger Handbook for flagger instructions and requirements

NOTE:

Minimum distance is 200 ft. at Start of Operation. Maximum distance is 2 miles but in no case to exceed one half the distance required for one normal day's operations, whichever is less.

TABLE OF SIGN SPACING	
SPEED MPH	LENGTH
55	500'
45-50	350'
≤40	200'

MINIMUM TRAFFIC CONTROL MOVING OPERATION

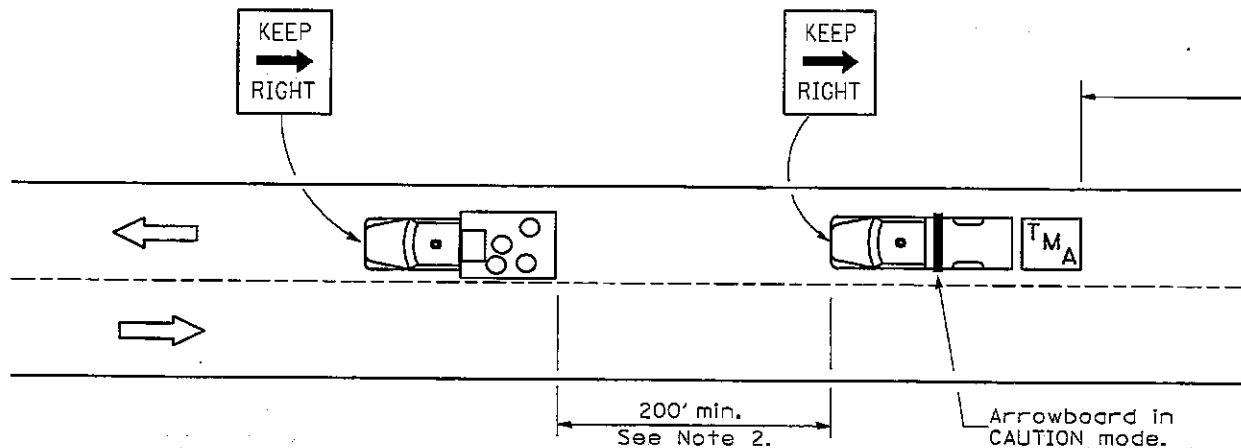

WZ 23

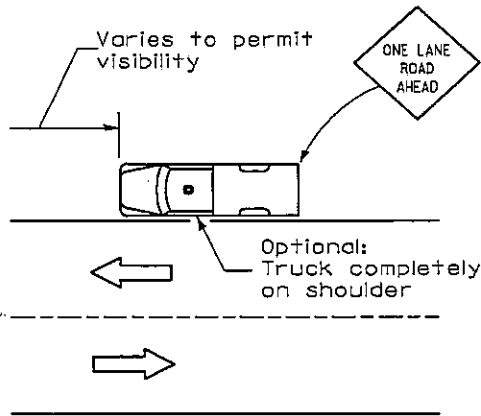

Notes:

1. All vehicles in convoy (except law enforcement vehicles) are to have headlights operating and are to display amber colored oscillating, rotating, flashing, or strobe lights. At least one amber light is to be visible from any direction.
2. The distance trailing vehicles follow will vary depending on the terrain. Whenever adequate stopping sight distance exists to rear, the protection vehicle shall maintain minimal distance. The protection vehicle should slow down in advance of vertical and horizontal curves that restrict sight distance.
3. Moving operations may be supported by additional traffic control devices.
4. In areas where visibility is not adequate, a shoulder sign truck may be added. It shall be in radio communication with the protective vehicle to provide proper distance to provide advance warning.

**ALL SPEEDS
INTERMITTENT /MOVING OPERATION
TWO-LANE,TWO-WAY TRAFFIC**

**WZ 24
DAY OR NIGHT**

Flaggers used for moving operations is dependent on the travelspeed. If the work operation moves too fast for flaggers, the flaggers may be omitted and the FLAGGER signs shall be replaced with WORKER signs. In lieu of flaggers, a protective vehicle with a TMA and an arrow board in CAUTION mode shall be used in advance of the work area.

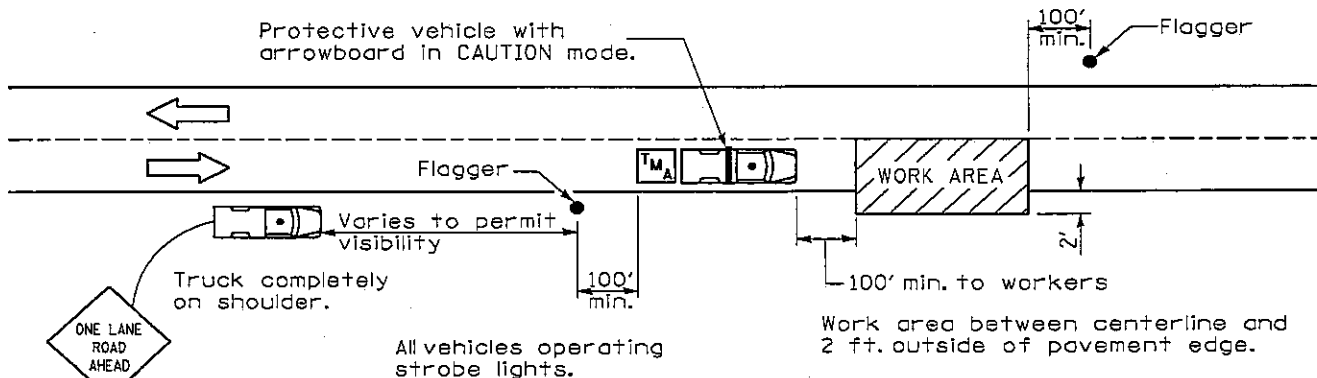

Shoulder sign truck in radio communication with protective vehicle to provide proper distance to provide advance warning. Required when visibility is not adequate.

See page 23 for criteria for utilizing one flagger.

**ALL SPEEDS
INTERMITTENT WORK ON ROADWAY
2 LANE ROADWAY
LESS THAN 5,000 ADT**

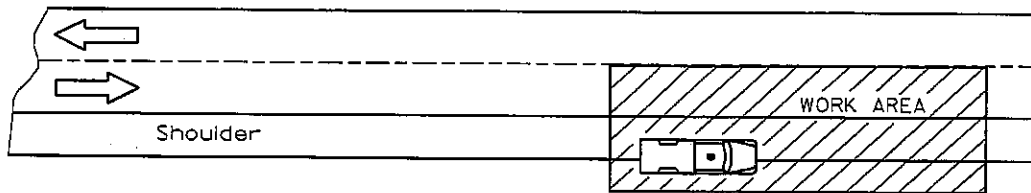

All vehicles operating
strobe lights.

A. May be performed without a flagger, provided all vehicles are completely off traveled lanes:

1. Each task must be performed with extreme care.
2. The amount of time the workers are on the pavement shall be minimized.
3. Workers shall enter onto the pavement only during appropriate gaps in traffic.
4. Adequate sight distance must be available to utilize this case.
5. If workers must remain in traffic lane and appropriate gaps do not exist, the lane must be closed with proper traffic control signs and devices.
6. Vehicle may not encroach onto the pavement.
7. When possible, work on the same side of road as the vehicle.
8. Vehicle shall have its strobe lights on.

B. No attempts shall be made to stop, slow, or direct traffic into another lane except by a properly equipped flagger with proper warning signs in place.

C. When it is necessary for the vehicle to stop on the roadway, traffic control shall be in accordance with the proper case.

D. This case is only allowed during non-peak traffic.

Multilanes

WZ 40

ALL SPEEDS MULTILANE UP TO 60 MINUTES

For left lane closure
use corresponding left
lane information. If
median ≥ 10 ft., signs
are required in median.

Less than 15 minutes, both trailing
truck and signs optional.
15 to 60 minutes, either trailing
truck or signs shall be utilized.

SPEED MPH	LENGTH	
	A	B
65	1000'	1600'
55-60	500'	500'
45-50	350'	350'
≤ 40	200'	200'

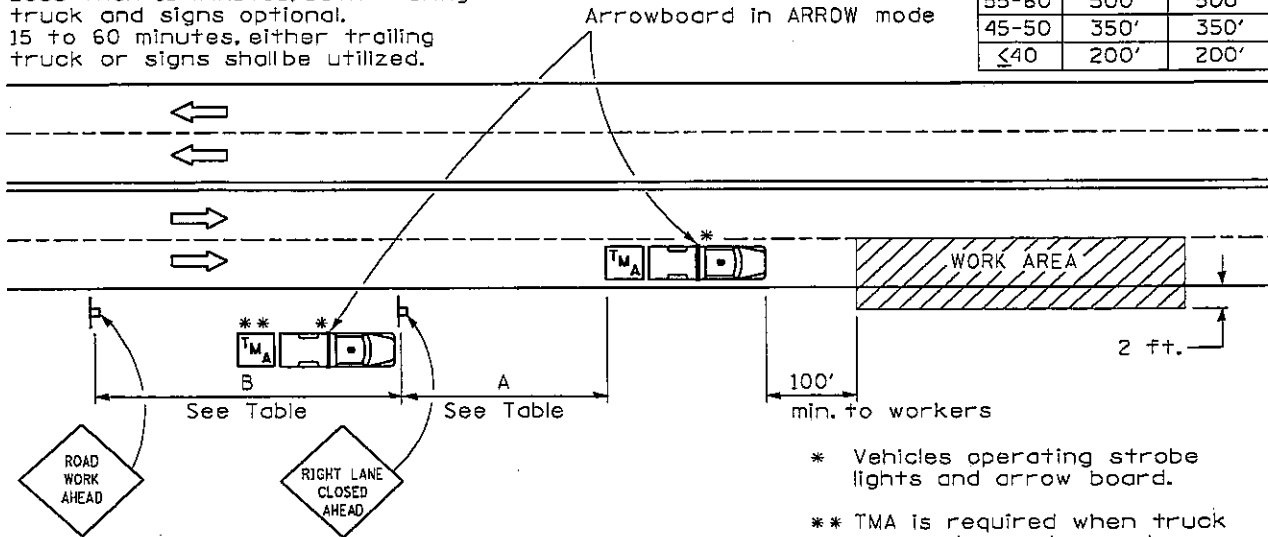

* Vehicles operating strobe
lights and arrow board.

** TMA is required when truck
encroaches onto roadway.

**ALL SPEEDS
ONE LANE CLOSED
NO TIME LIMIT**

Signs not required in median when median is less than 10' wide.

Arrow Board in Arrow Mode

Cones on lane line
 ≤ 45 mph - 40' ctrs.
 ≥ 50 mph - 80' ctrs.

When protective vehicle is moved forward to protect workers, an arrow board shall be placed at the start of the taper.

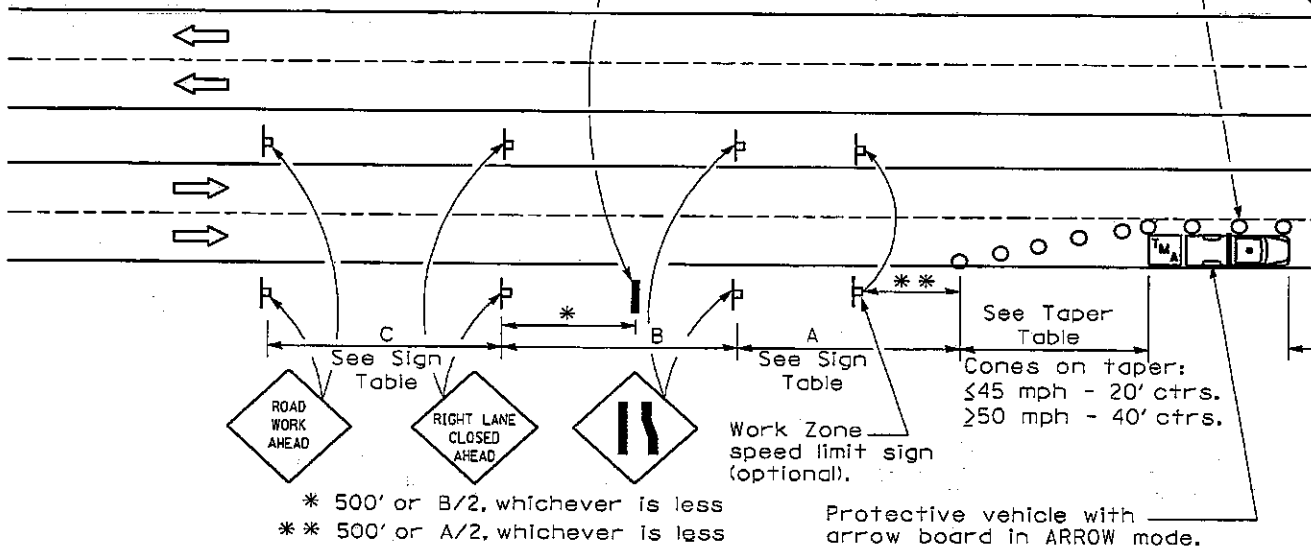

WZ 41

Add these signs when work is being performed in the left lane for undivided highway.

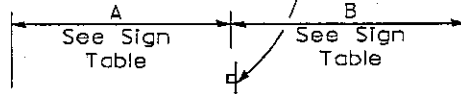
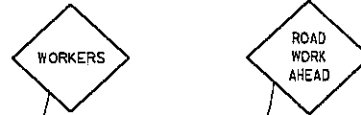

All vehicles operating strobe lights.

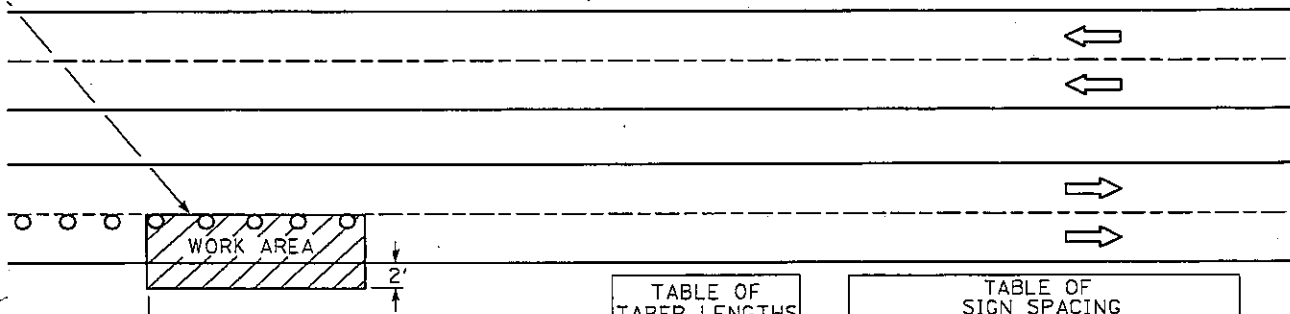

100' minimum to workers.

SPEED MPH	LENGTH
65	780'
55	660'
45	540'
40	320'
35	245'
30	180'

SPEED MPH	LENGTH A	LENGTH B	LENGTH C
65	1,000'	1,600'	2,600'
55-60	500'	500'	500'
45-50	350'	350'	350'
<40	200'	200'	200'

When work is being performed in the left lane, corresponding left lane information shall be used.

**ALL SPEEDS
MULTILANE UNDIVIDED
LEFT LANE CLOSURE
NO TIME LIMIT**

TABLE OF SIGN SPACING			
SPEED MPH	LENGTH A	LENGTH B	LENGTH C
55	500'	500'	500'
45-50	350'	350'	350'
≤40.	200'	200'	200'

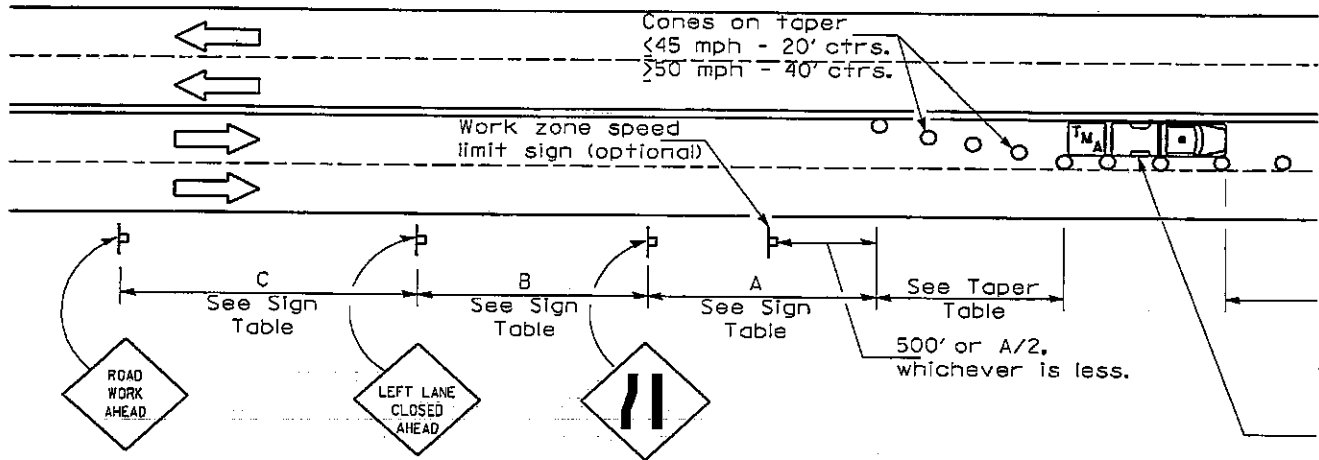

WZ 42

All vehicles operating strobe lights.

Note: Opposing inside lane should be closed when work is within 2' of centerline.

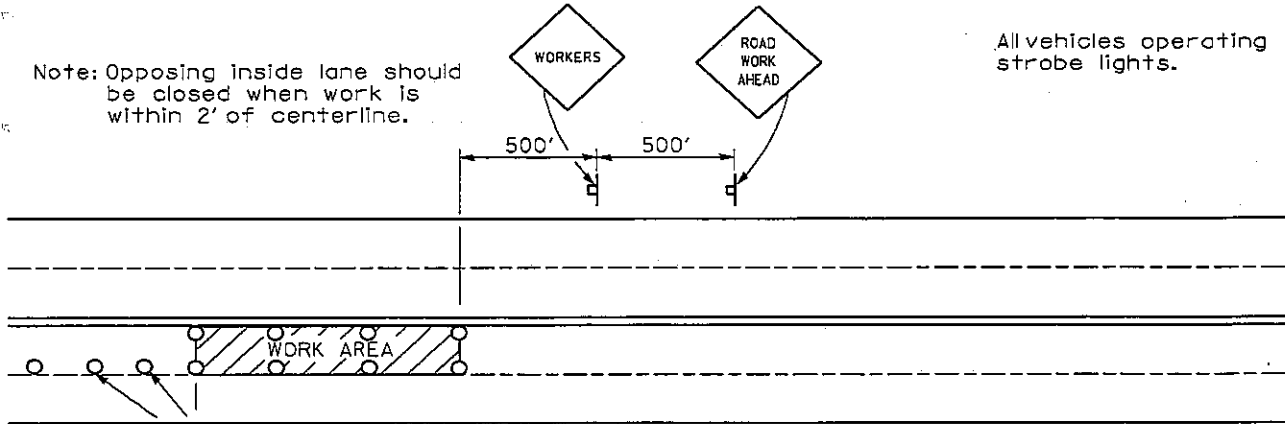

100'

Cones on lane line
 <45 mph - 40' ctrs.
 ≥50 mph - 80' ctrs.
 (min. of 3)

Protective vehicle with arrowboard in ARROW mode.

TABLE OF TAPER LENGTHS	
SPEED MPH	LENGTH
55	660'
45	540'
40	320'
35	245'
30	180'

MULTILANE DIVIDED TWO LANE CLOSURE NO TIME LIMIT

Signs not required in median
when median is less than 10' wide.

Notes:

Cones on taper:
 ≤ 45 mph - 20' ctrs.
 ≥ 50 mph - 40' ctrs.

Cones on lane lines:
 ≤ 45 mph - 40' ctrs.
 ≥ 50 mph - 80' ctrs.

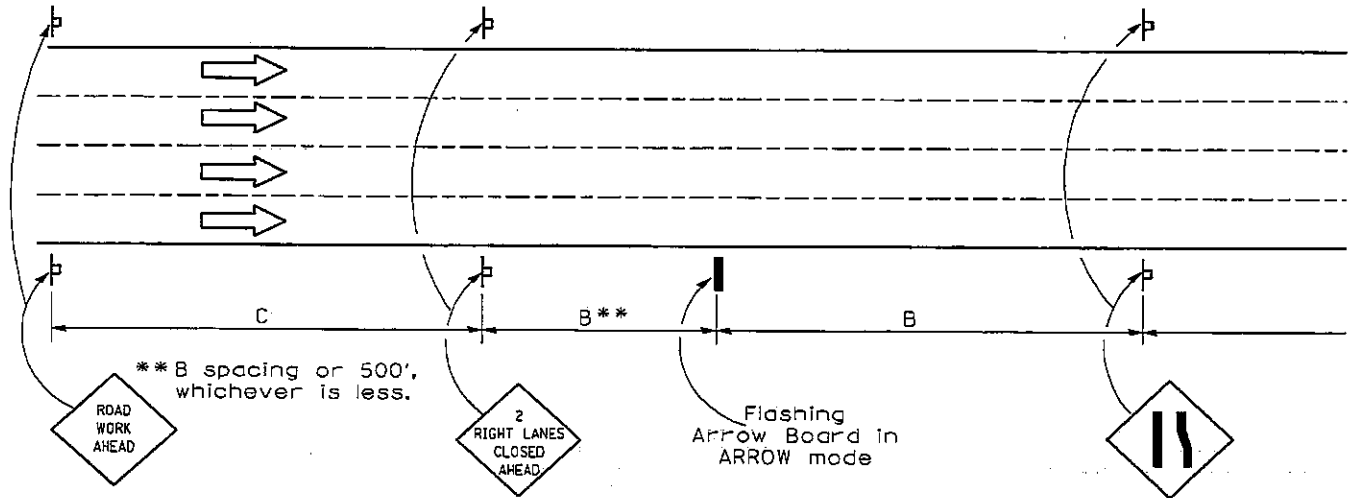

WZ 44

SPEED MPH	LENGTH A	LENGTH B	LENGTH C
65	1,000'	1,600'	2,600'
55-60	500'	500'	500'
45-50	350'	350'	350'
≤40	200'	200'	200'

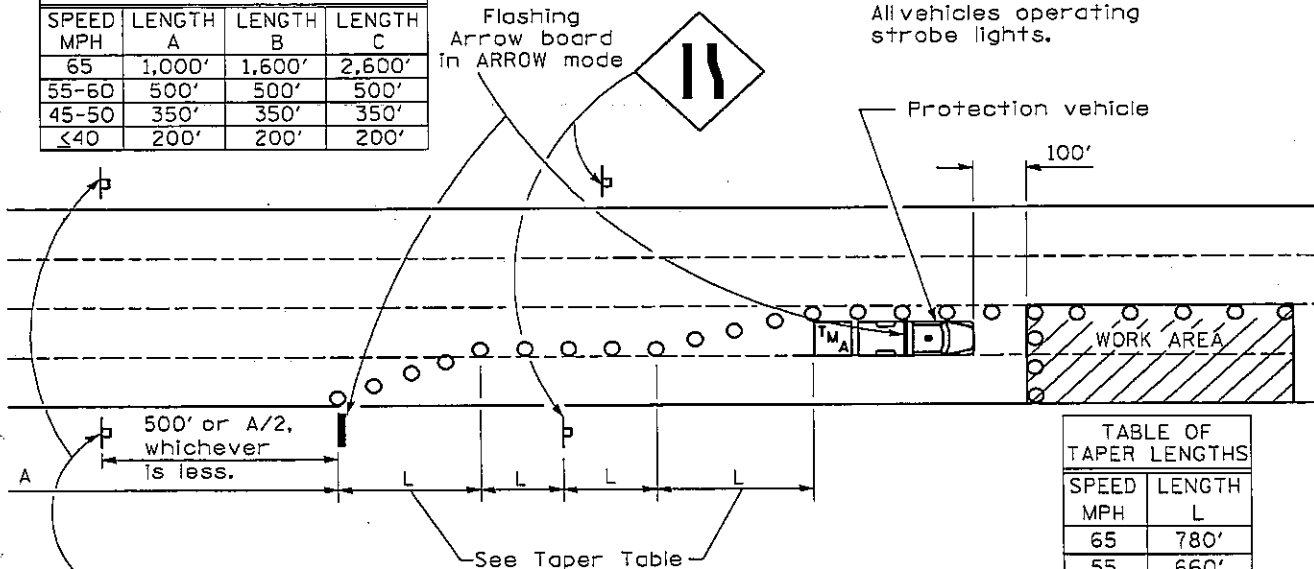

SPEED MPH	LENGTH L
65	780'
55	660'
45	540'
40	320'
35	245'
30	180'

Note:
When center lane remains closed,
use WZ 45 after work is complete
and workers are not present.

Work zone speed limit sign (optional)

ALL SPEEDS CENTER LANE CLOSURE NO WORKERS PRESENT

*** Note:**
This case may only be utilized when workers are not present.

Use WZ 44 while workers are present.

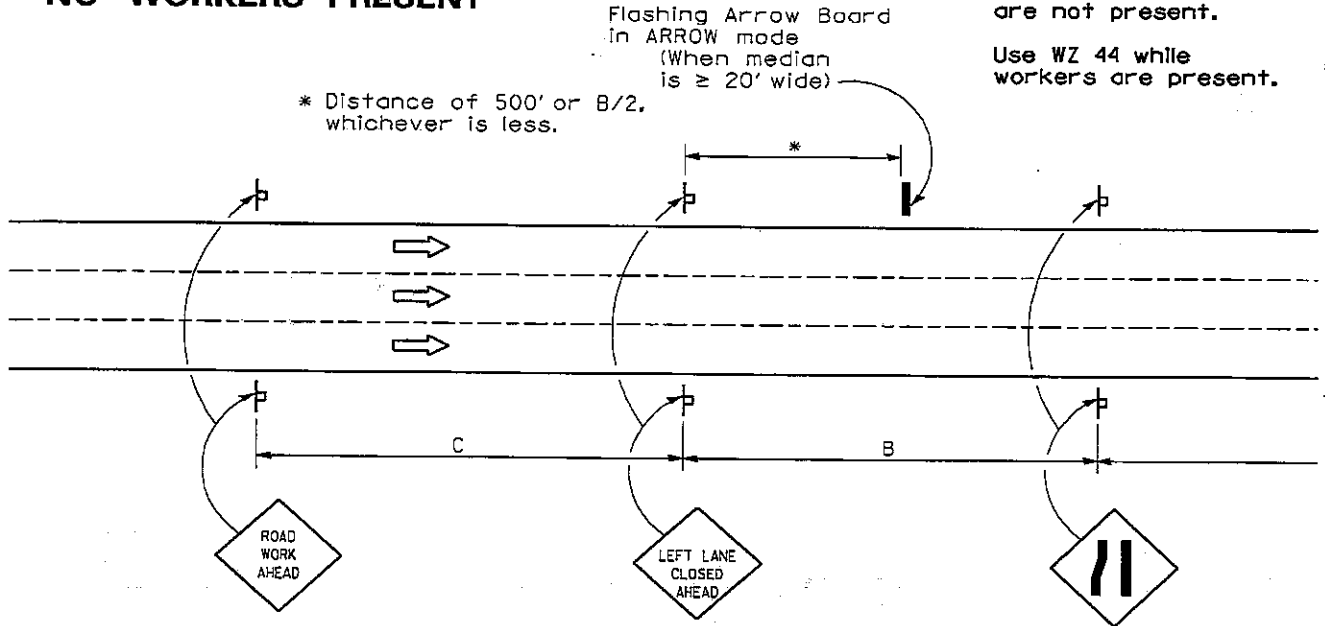

WZ 45

Flashing Arrow Board

SPEED MPH	LENGTH A	LENGTH B	LENGTH C
65	1,000'	1,600'	2,600'
55-60	500'	500'	500'
45-50	350'	350'	350'
<40	200'	200'	200'

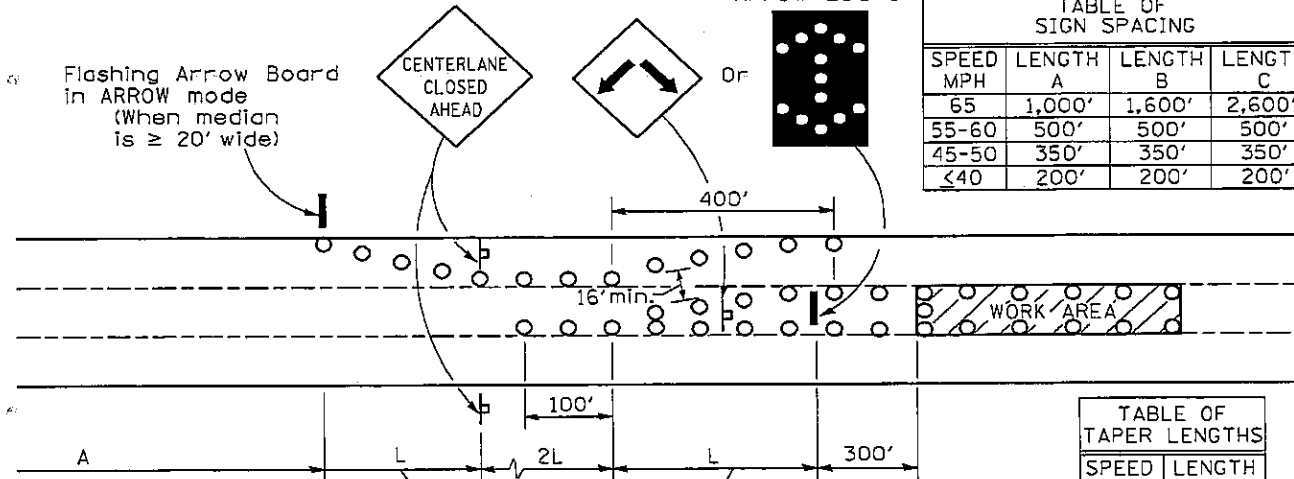

Notes:

Cones on taper:

≤ 45 mph - 20' ctrs.

≥ 50 mph - 40' ctrs.

Cones on lane lines:

≤ 45 mph - 40' ctrs.

≥ 50 mph - 80' ctrs.

TABLE OF TAPER LENGTHS

SPEED MPH	LENGTH L
65	780'
55	660'
45	540'
40	320'
35	245'
30	180'

**ALL SPEEDS
INTERMITTENT / MOVING OPERATION
NO TIME LIMIT
MORE THAN 4 MILE PER DAY**

WZ 46

If work production < 4 mile/day,
WZ48 must be utilized.

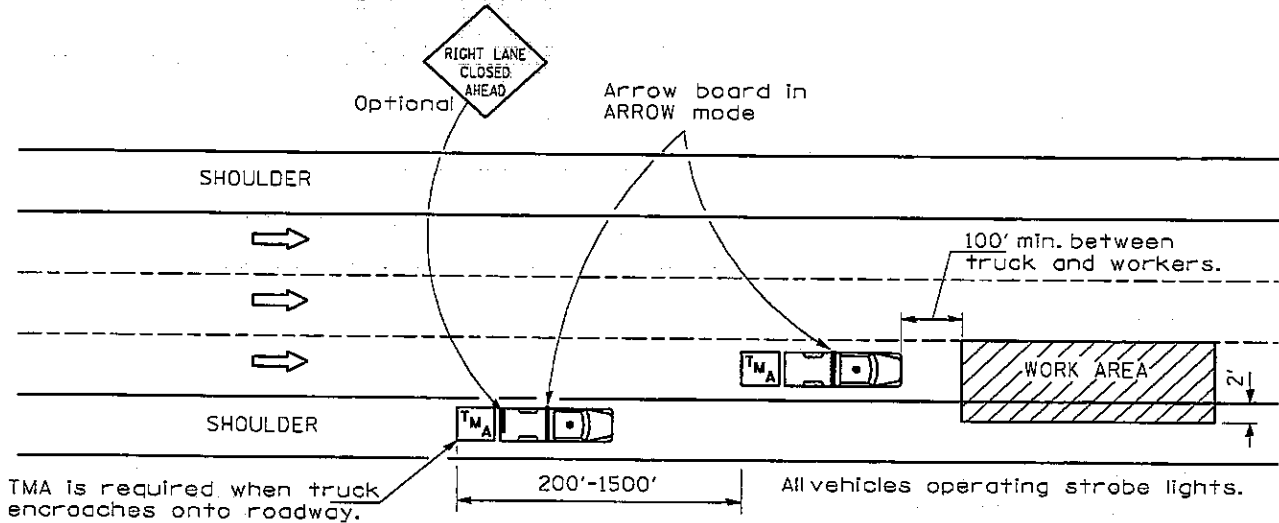

**45 MPH OR LESS
INTERMITTENT / MOVING OPERATION
WITH CURB AND GUTTER
ONE LANE CLOSURE**

WZ 47

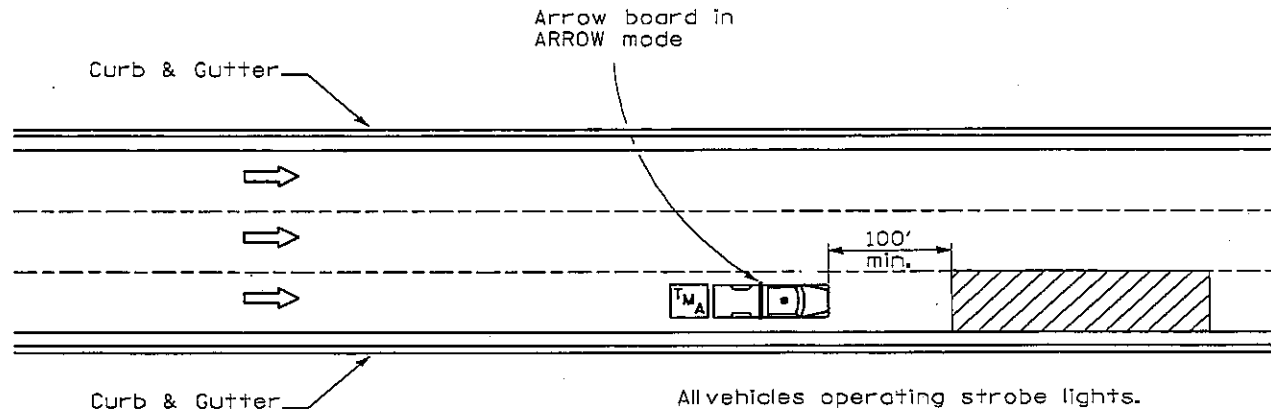

**ALL SPEEDS
INTERMITTENT / MOVING OPERATION
NO TIME LIMIT
LESS THAN 4 MILE PER DAY**

Flashing Arrow board in ARROW mode
All vehicles operating strobe lights

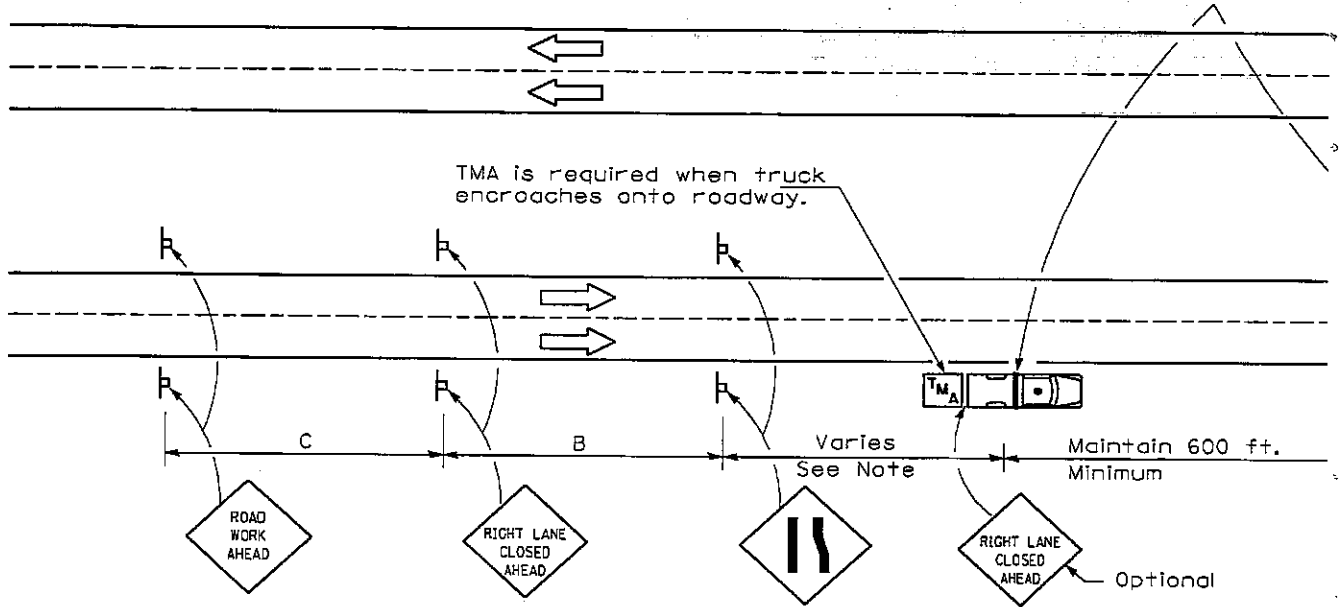

Note:
 Minimum distance is 200 ft. at start of operation. Maximum distance is two miles, but in no case to exceed one half the length required for one normal day's operation.

WZ 48

Signs not required in median when median less than 10 ft. wide.

For left lane closure use corresponding left lane signage.

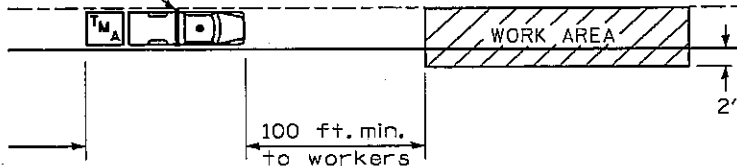
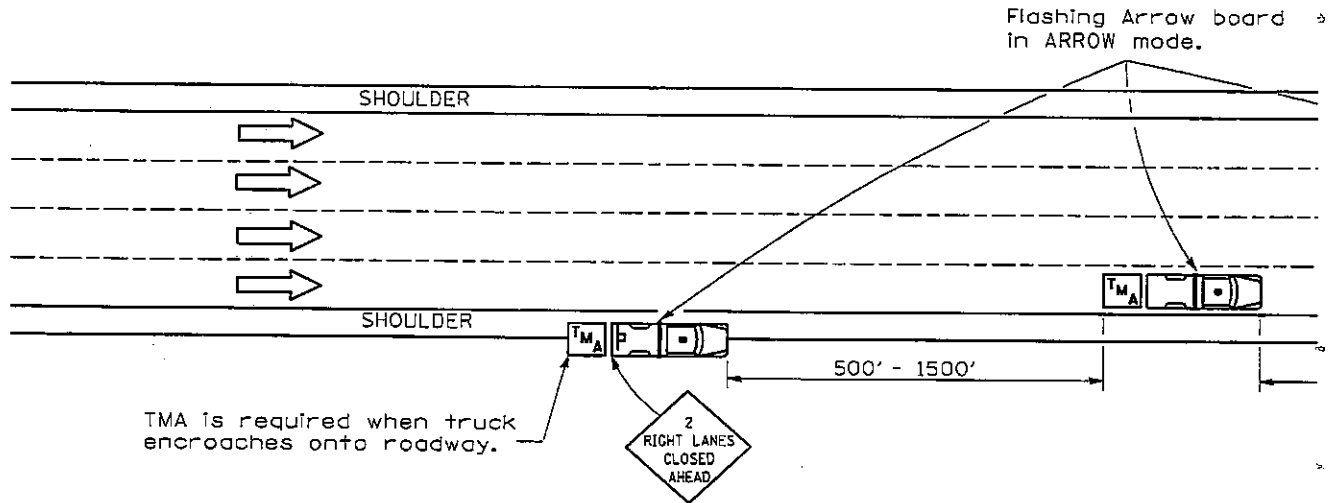
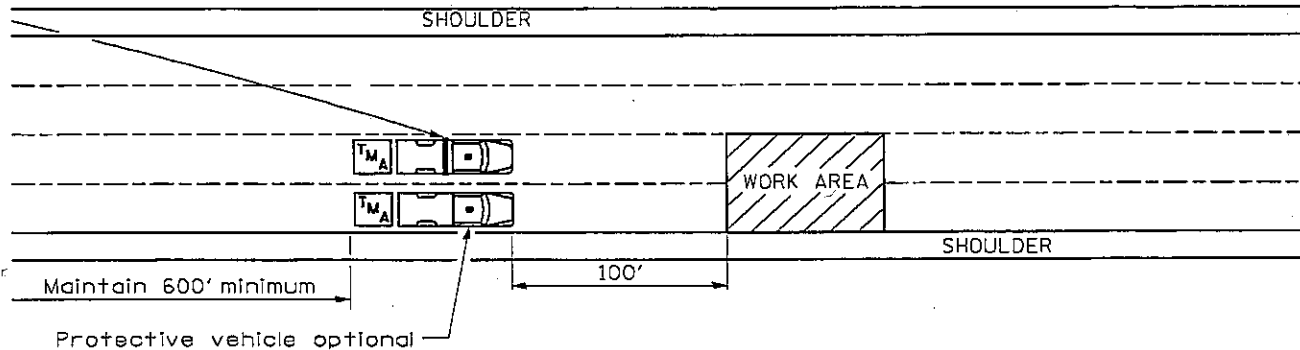

TABLE OF SIGN SPACING			
SPEED MPH	LENGTH A	LENGTH B	LENGTH C
65	1,000'	1,600'	2,600'
55-60	500'	500'	500'
45-50	350'	350'	350'
<40	200'	200'	200'

INTERMITTENT / MOVING OPERATION TWO LANE CLOSURE



WZ 49



All vehicles operating strobe lights.

**45 MPH OR LESS
 CENTER LANE USED AS
 THRU LANE
 NO TIME LIMIT
 UP TO 60 MINUTES, NO SIGNS REQUIRED
 FOR MORE THAN 60 MINUTES, SIGNS REQUIRED**

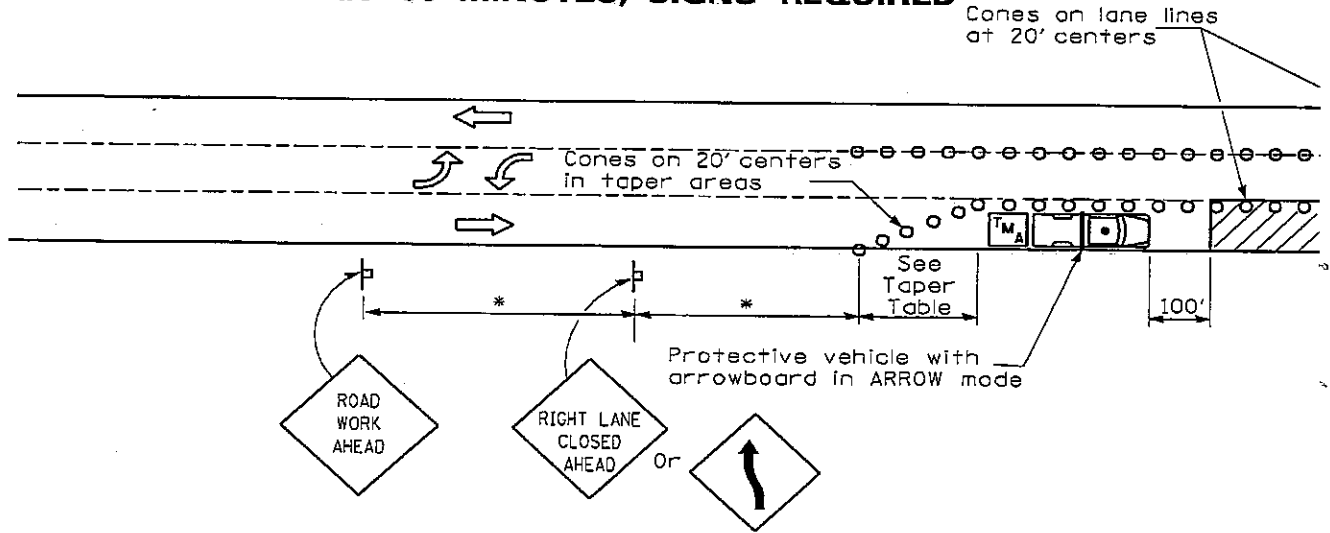

WZ 50

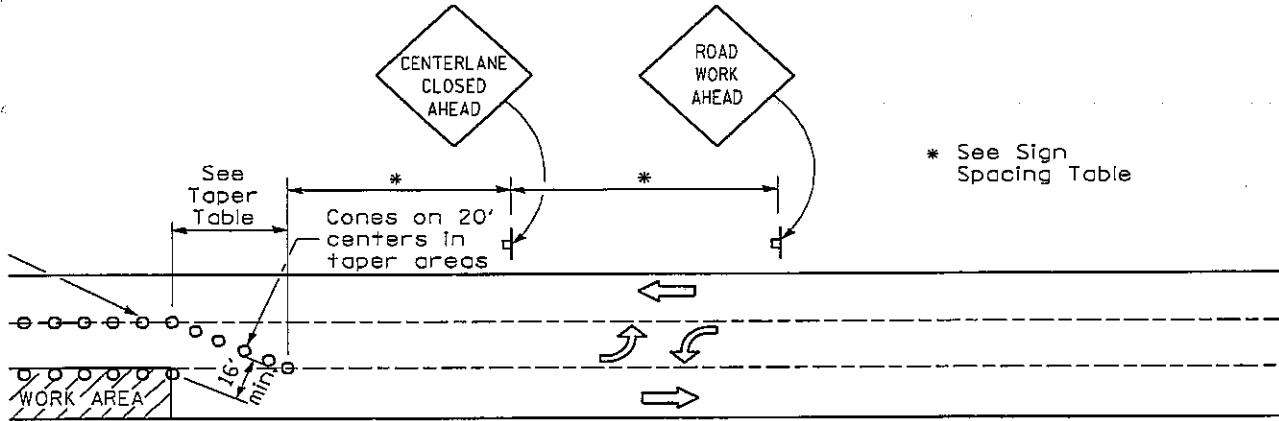

All vehicles operating
strobe lights

Taper Table Length	
Speed	Length
45	270'
40	170'
35	125'
30	90'

Sign Spacing	
Speed	Length
45	350'
≤40	200'

**45 MPH OR LESS
 CENTER LANE CLOSURE
 NO TIME LIMIT
 UP TO 60 MINUTES, NO SIGNS REQUIRED
 FOR MORE THAN 60 MINUTES, SIGNS REQUIRED**

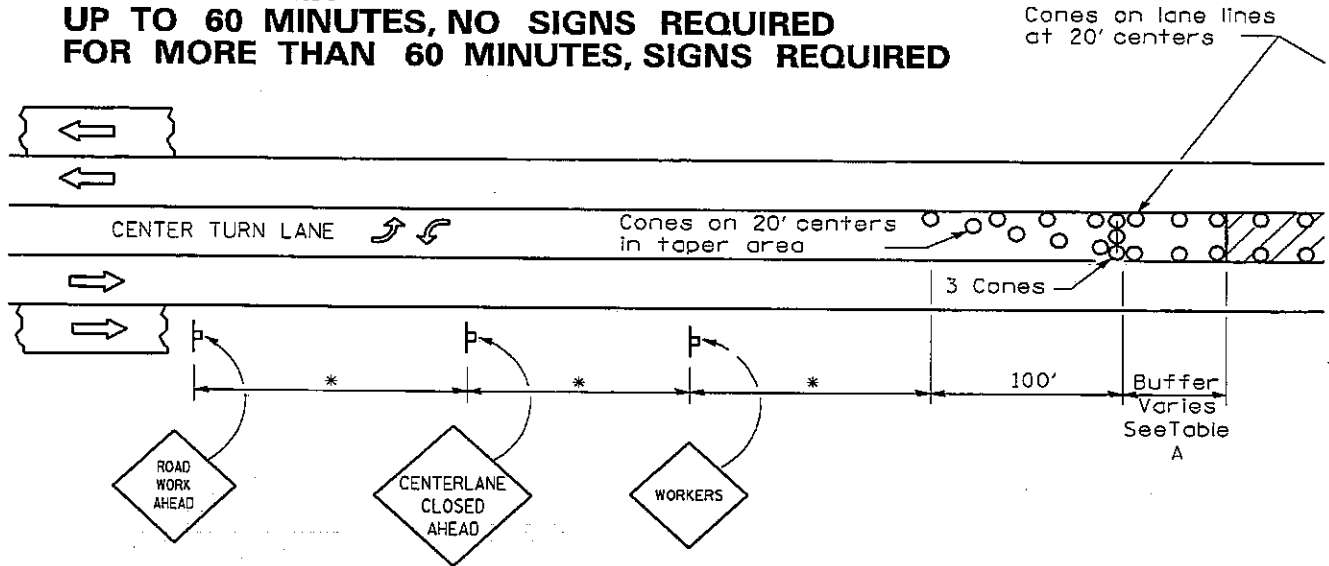

WZ 51

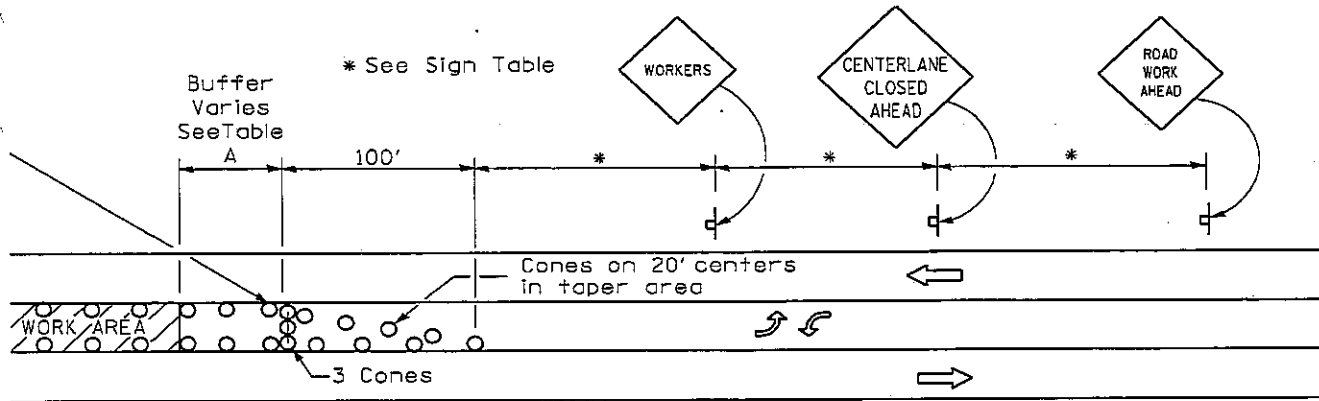

If operational problems are evident and caused by left-turning vehicles, the R3-9b signs in the immediate area of the work-zone should be temporarily covered and/or adjustments made in the lengths of the work area, buffer areas and tapers. All dimensions shown may be increased.

TABLE A	
SPEED MPH	BUFFER LENGTH
45	220'
40	170'
35	120'
30	85'

Sign Spacing	
Speed	Length
45	350'
≤40	200'

ALL SPEEDS MULTILANE MOVING OPERATION

Optional:
TMA required when truck
encroaches onto roadway.

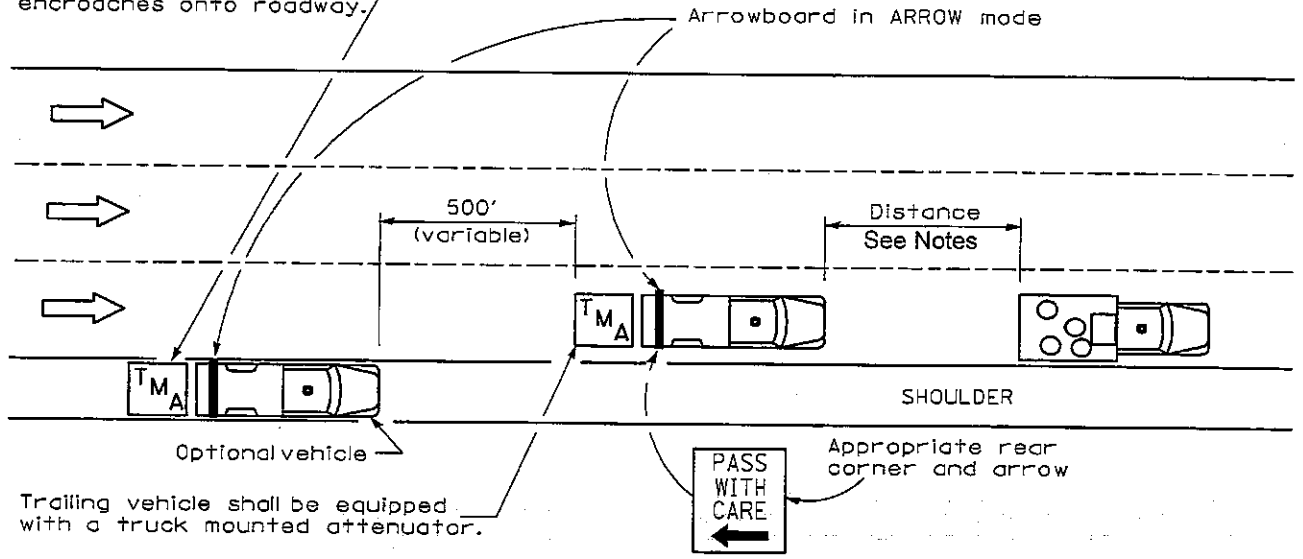

WZ 52

Notes:

All vehicles in convoy (except law enforcement vehicles) are to have headlights operating and are to display an amber colored oscillating, rotating, flashing or strobe lights. At least one amber light is to be visible from any direction.

Distance trailing vehicle(s) follows vary depending on terrain, whenever adequate stopping sight distance exists to rear, the protection vehicle shall maintain minimal distance. The protection vehicle should slow down in advance of vertical and horizontal curves that restrict sight distance.

On curb and gutter sections, truck on shoulder is not required.

Ramps

RAMP WORK OF SHORT DURATION INTERMEDIATE TYPE WORK UP TO 60 MINUTES

WZ 60

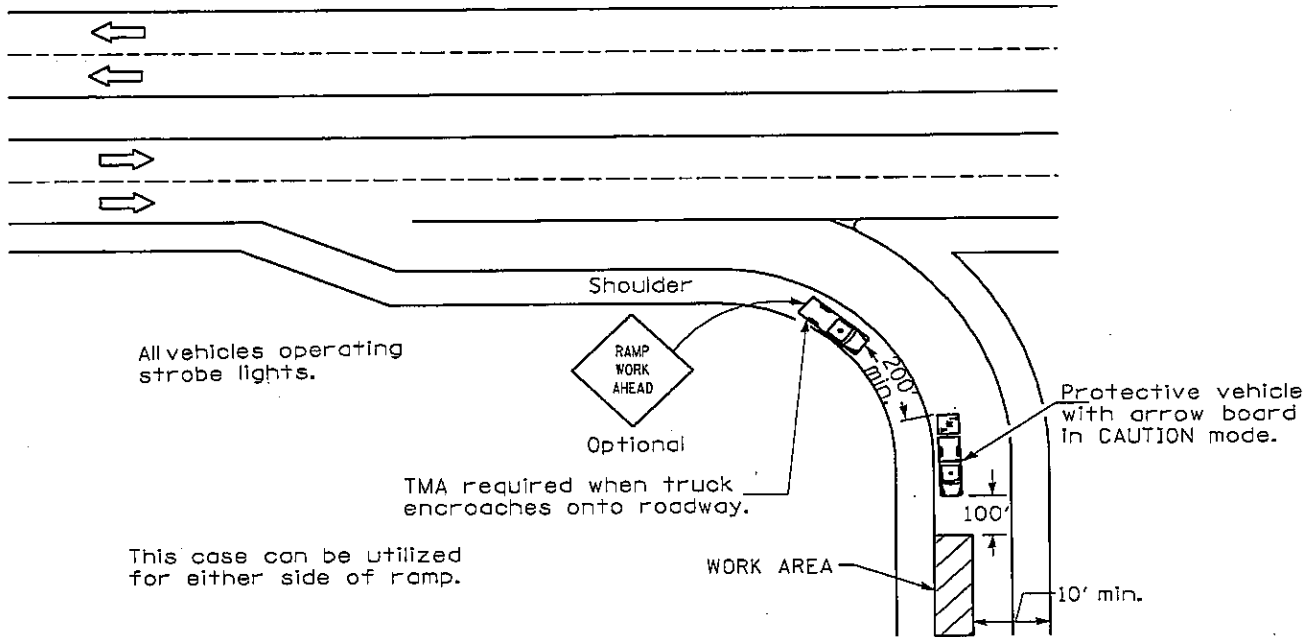

PARTIAL EXIT RAMP LANE CLOSURE NO TIME LIMIT

WZ 61

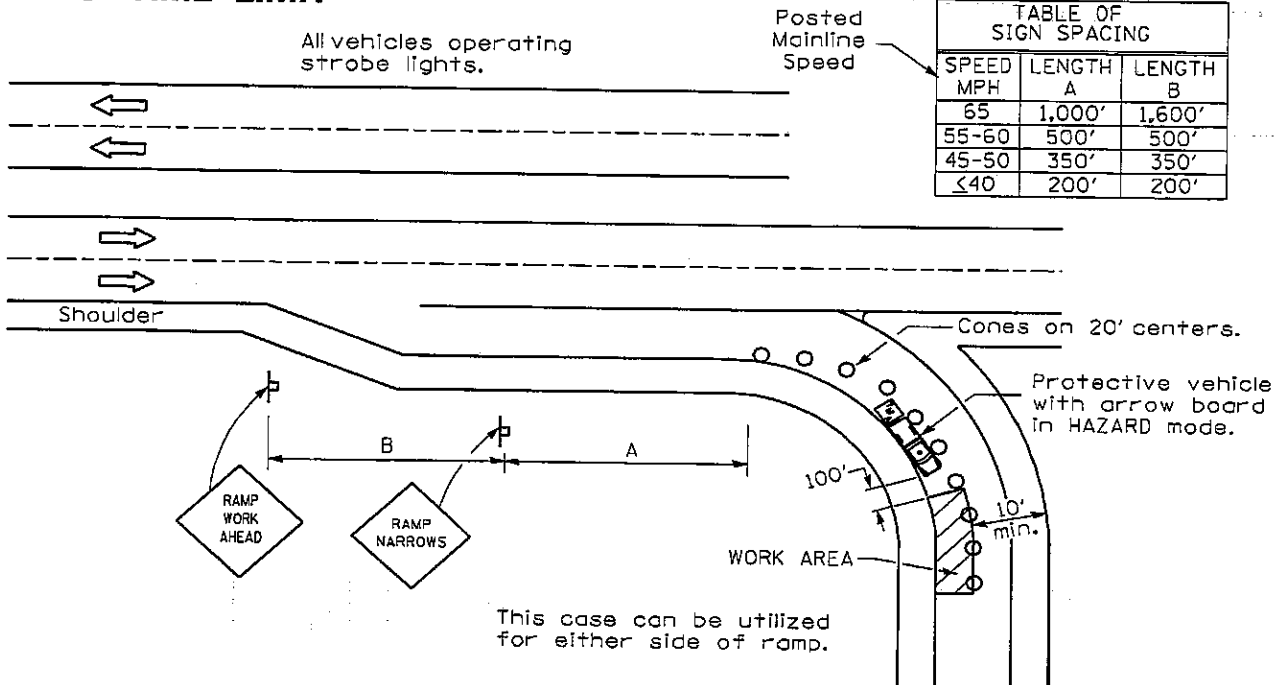

TYPICAL ENTRANCE RAMP APPLICATION

If room on ramp, space signs on ramp

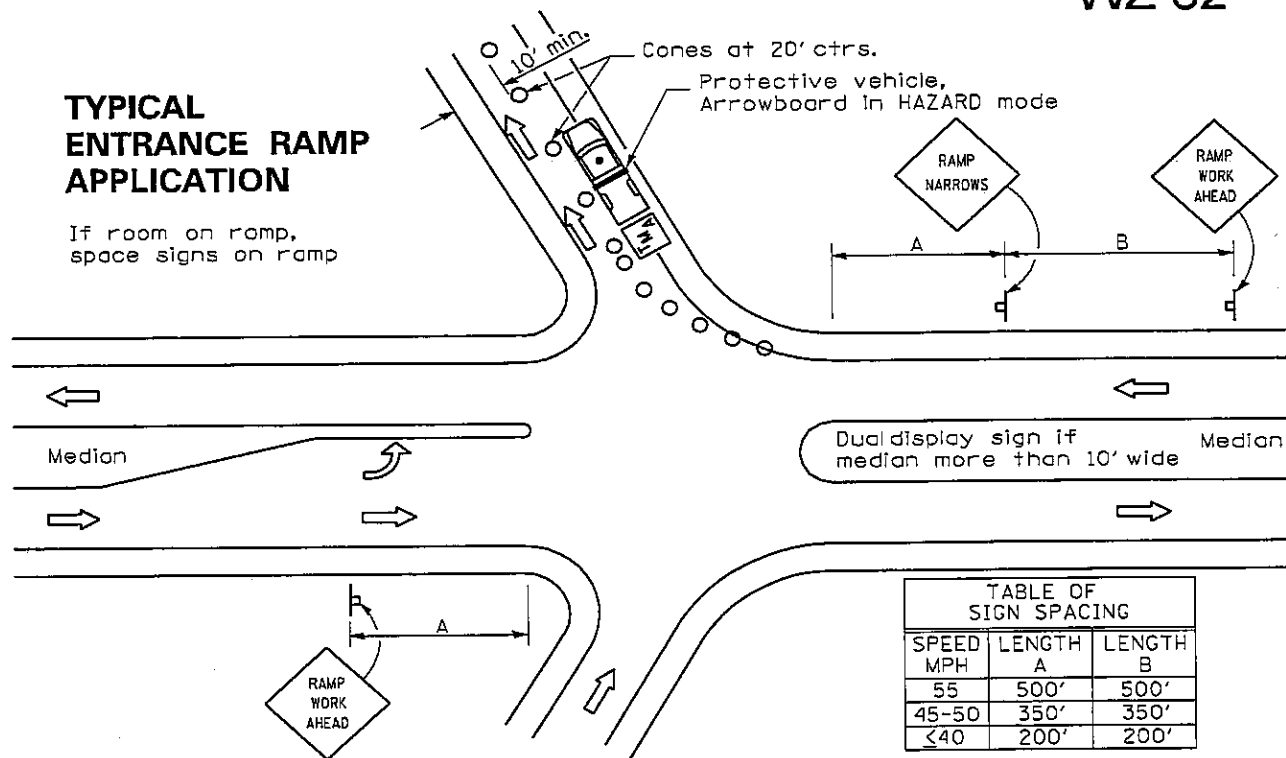

TABLE OF SIGN SPACING

SPEED MPH	LENGTH A	LENGTH B
55	500'	500'
45-50	350'	350'
<40	200'	200'

Intersections

**ALL SPEEDS
SIDEROAD WORK
TWO LANE, TWO WAY
15 MINUTES OR LESS**

WZ 91

All vehicles operating
strobe lights.

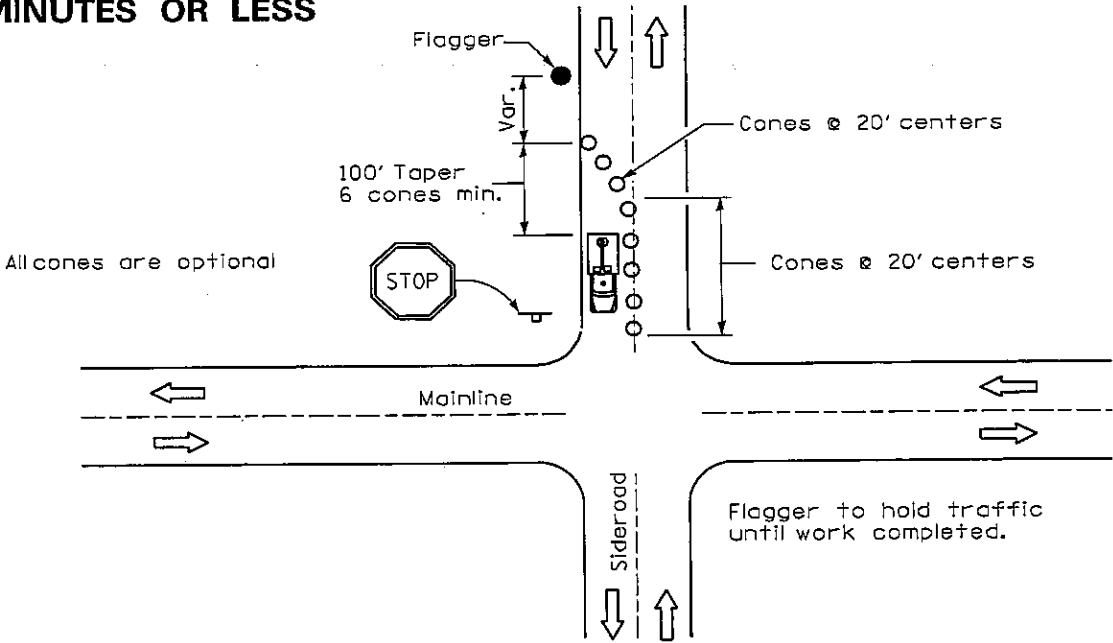

**45 MPH OR LESS
INTERSECTION
NO TIME LIMIT**

* TABLE OF SIGN SPACING	
SPEED MPH	LENGTH
55	500'
45-50	350'
<40	200'

CONES ON TAPER	CONES ON LANE LINE
≤ 45 mph - 20' centers	≤ 45 mph - 40' centers
≥ 50 mph - 40' centers	≥ 50 mph - 80' centers

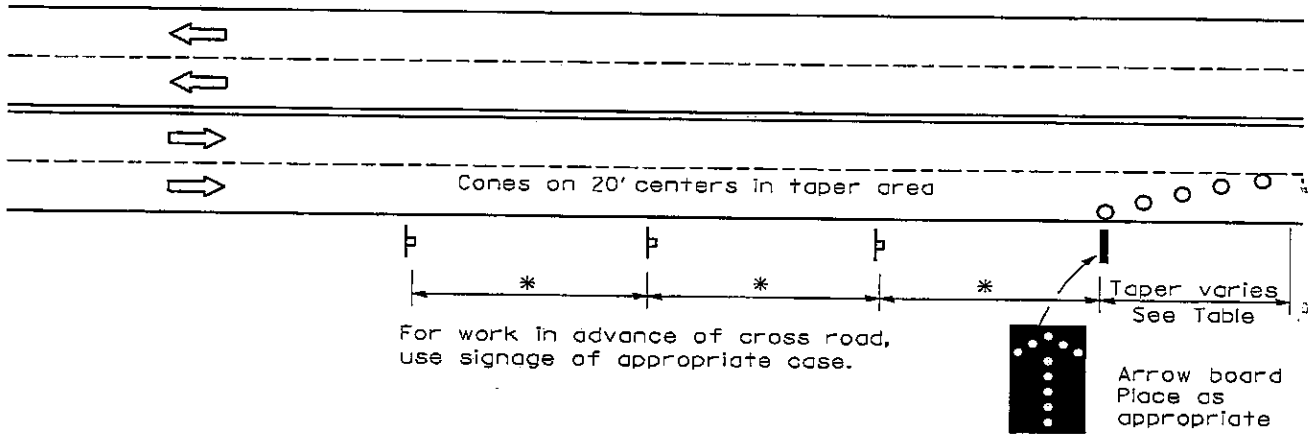
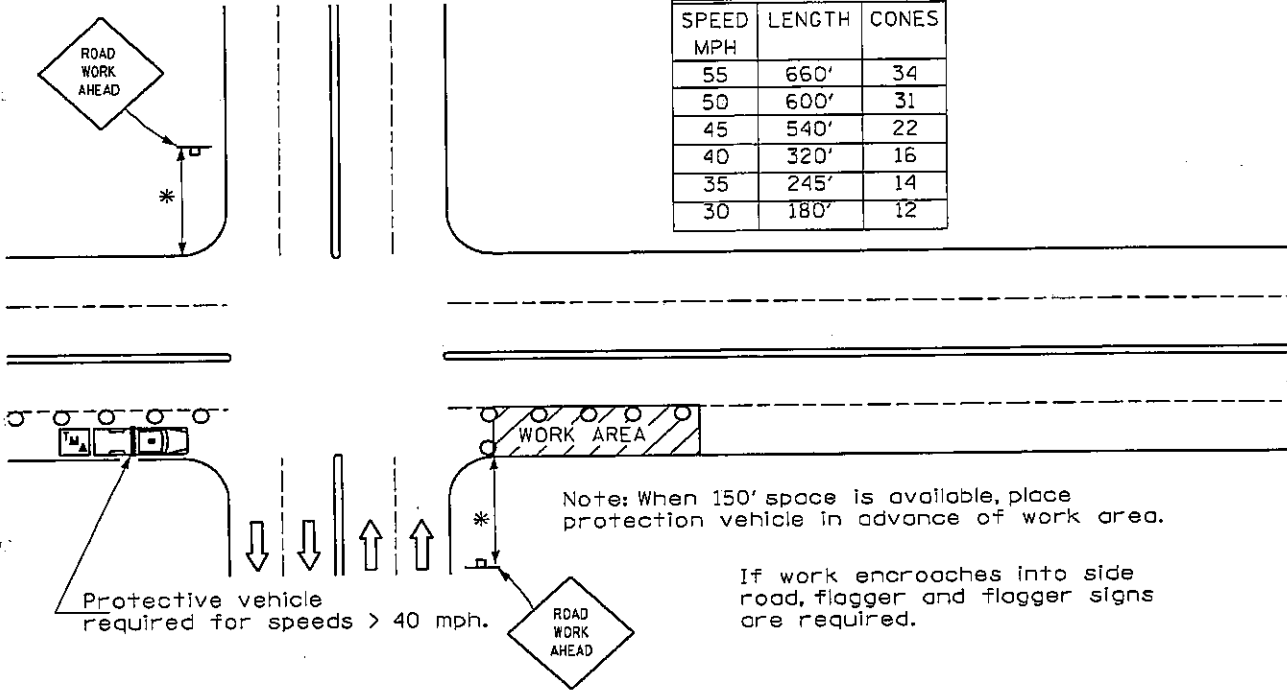

TABLE OF TAPER LENGTHS		
SPEED MPH	LENGTH	CONES
55	660'	34
50	600'	31
45	540'	22
40	320'	16
35	245'	14
30	180'	12



ALL SPEEDS MULTILANE DIVIDED LEFT TURN LANE CLOSURE NO TIME LIMIT

Cones on lane line:
 ≤45 mph - 40' centers
 ≥50 mph - 80' centers

Signs in median may be omitted
 when median is less than 10ft wide.

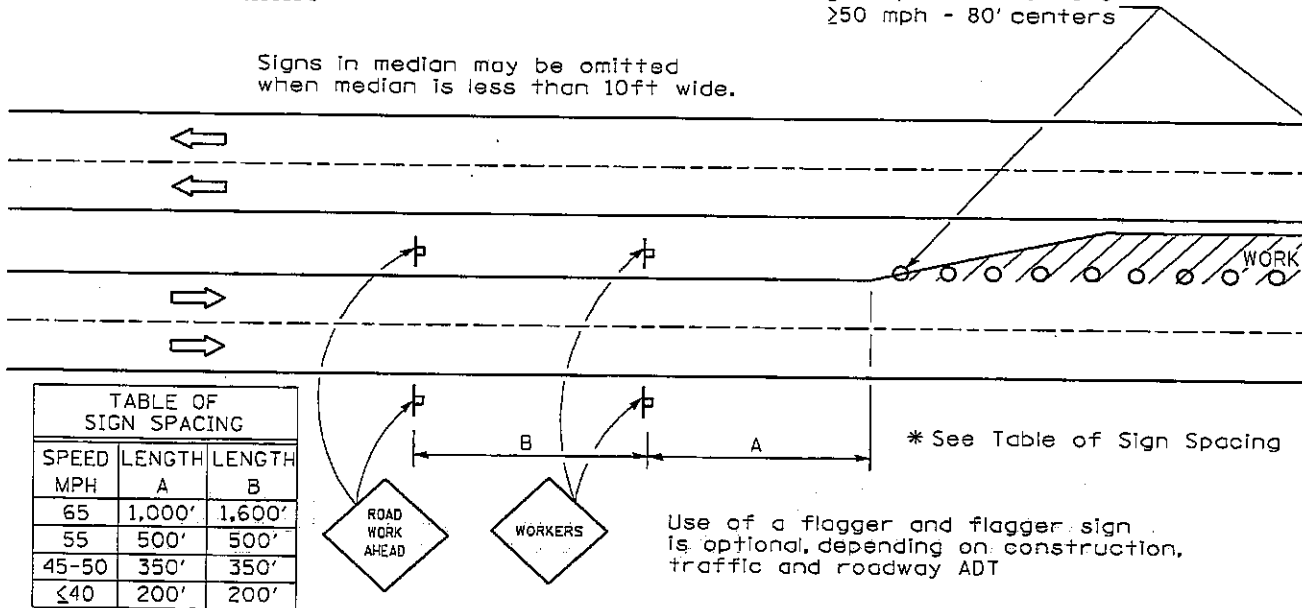

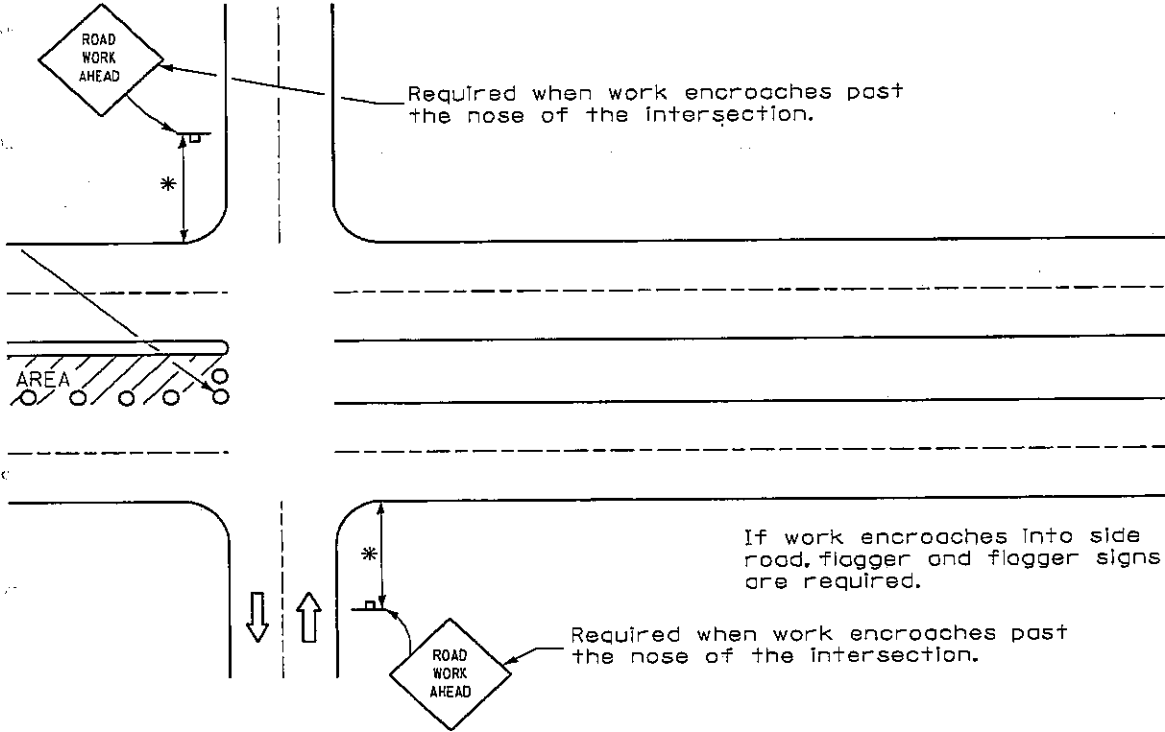

**INTERSECTION WORK
15 MINUTES OR LESS**

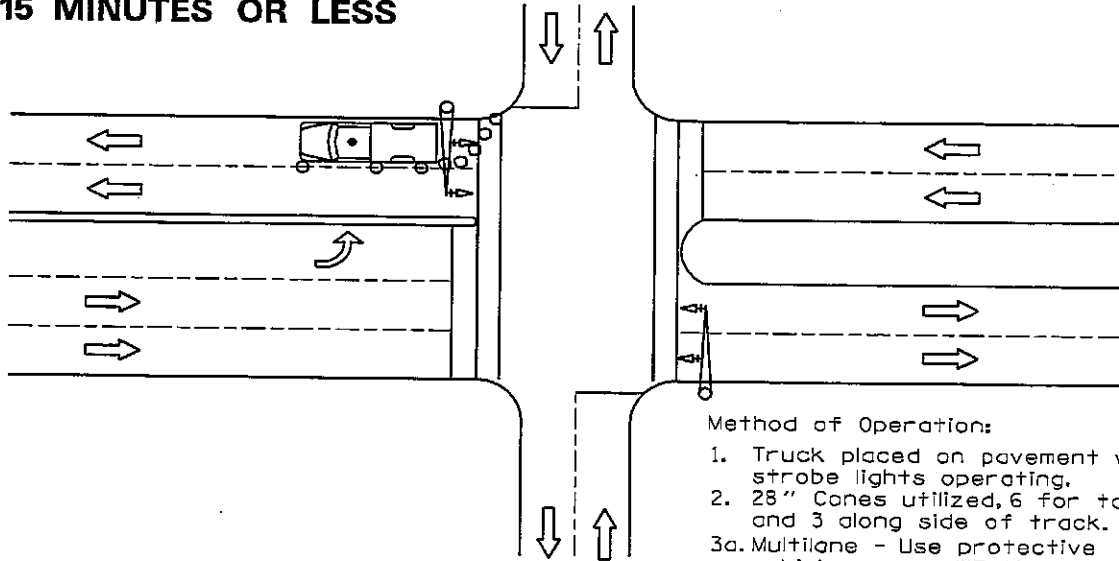

Method of Operation:

1. Truck placed on pavement with strobe lights operating.
2. 28" Cones utilized, 6 for taper and 3 along side of track.
- 3a. Multilane - Use protective vehicle as per WZ-40.
- 3b. 2-Lane - Control traffic as per WZ-20.

**ALL SPEEDS
TURN LANE CLOSURE
15 MINUTES OR LESS**

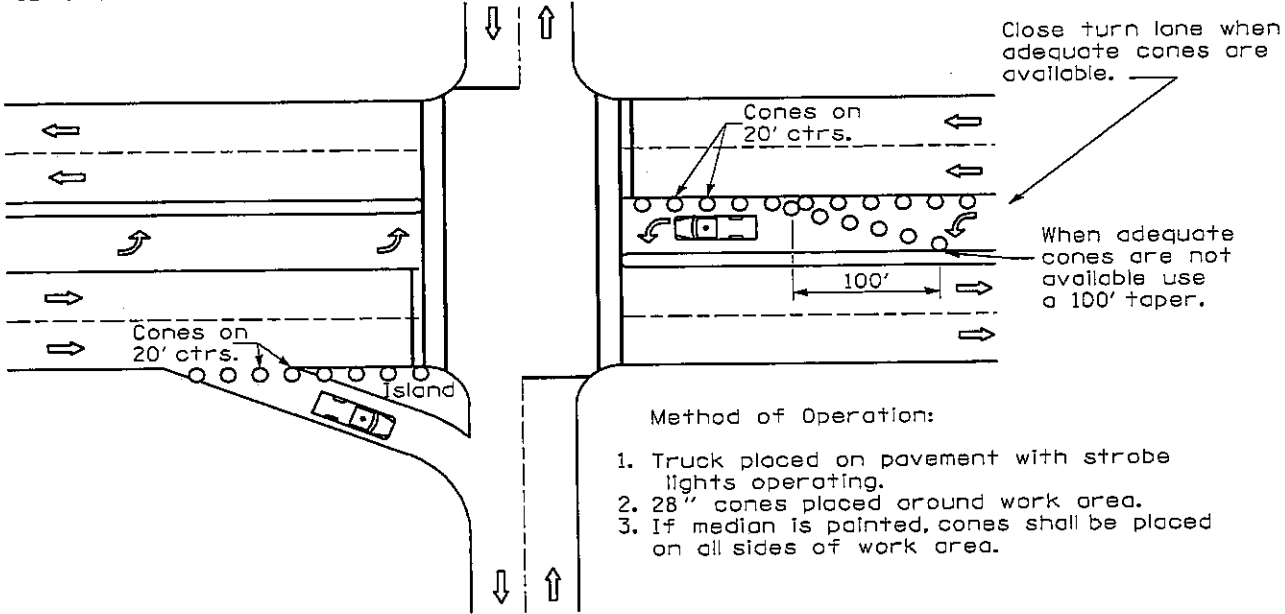

Method of Operation:

1. Truck placed on pavement with strobe lights operating.
2. 28" cones placed around work area.
3. If median is painted, cones shall be placed on all sides of work area.

Miscellaneous

WZ 96

**ALL SPEEDS
INTERMITTENT/MOVING OPERATIONS
WITH FREQUENT STOPS AND NO
WORKERS OUT OF VEHICLE**

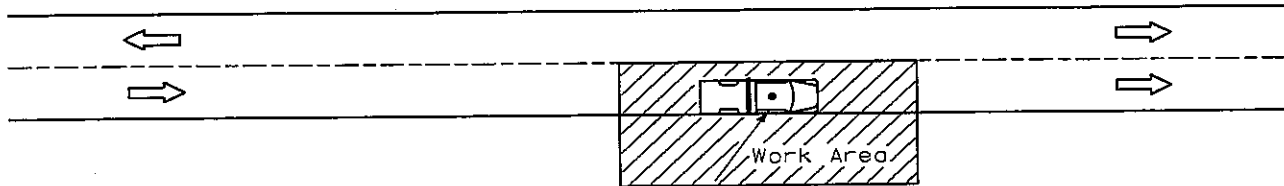

All vehicles operating
strobe lights.

Special Cases Cases WZ-B Bridges

BRIDGE INSPECTION 2 LANE 2 WAY ROADWAY

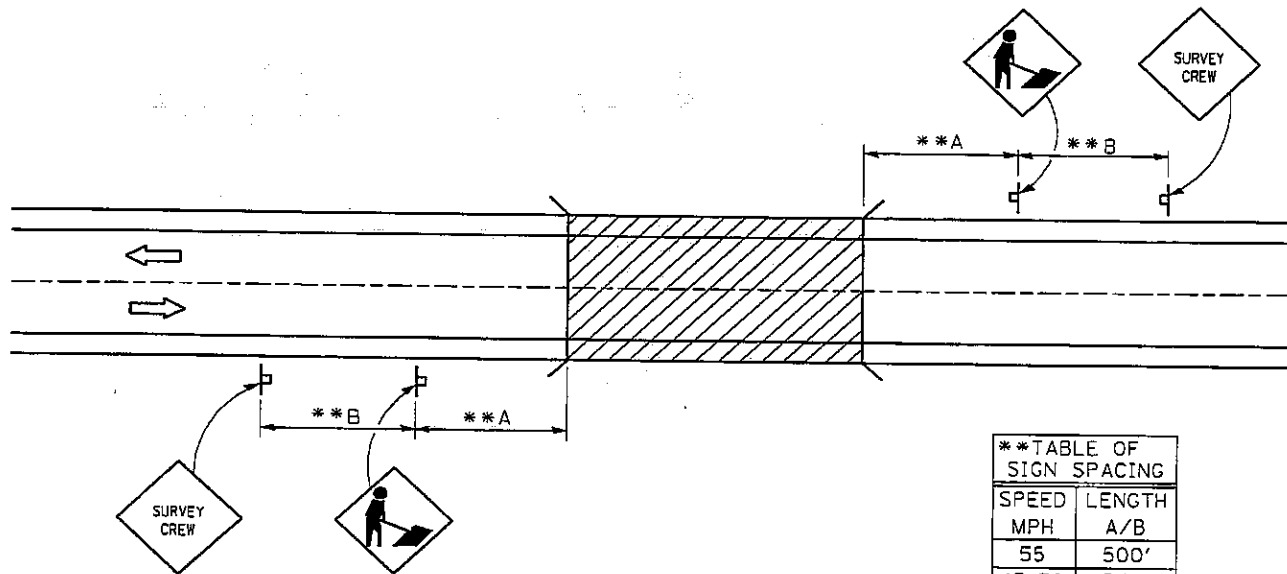

****TABLE OF
SIGN SPACING**

SPEED MPH	LENGTH A/B
55	500'
45-50	350'
≤40	200'

Notes:

May be performed without a flagger, provided:

1. Each task must be performed with extreme care.
2. The amount of time the workers are on the pavement shall be minimized.
3. Workers shall enter onto the pavement only during appropriate gaps in traffic.
4. Adequate sight distance must be available to utilize this case.
5. If workers must remain in traffic lane and appropriate gaps do not exist, the lane must be closed with proper traffic control signs and devices.
6. Vehicle may not encroach onto the pavement.
7. Vehicle shall have its strobe lights on.

No attempts shall be made to stop, slow, or direct traffic into another lane except by a properly equipped flagger with proper warning signs in place.

When it is necessary for the vehicle to stop on the roadway, traffic control shall be in accordance with the proper case.

This case is allowed during non-peak traffic.

Full lane closure should be considered when work at one location would exceed one hour.

BRIDGE INSPECTION MULTILANE DIVIDED HIGHWAY

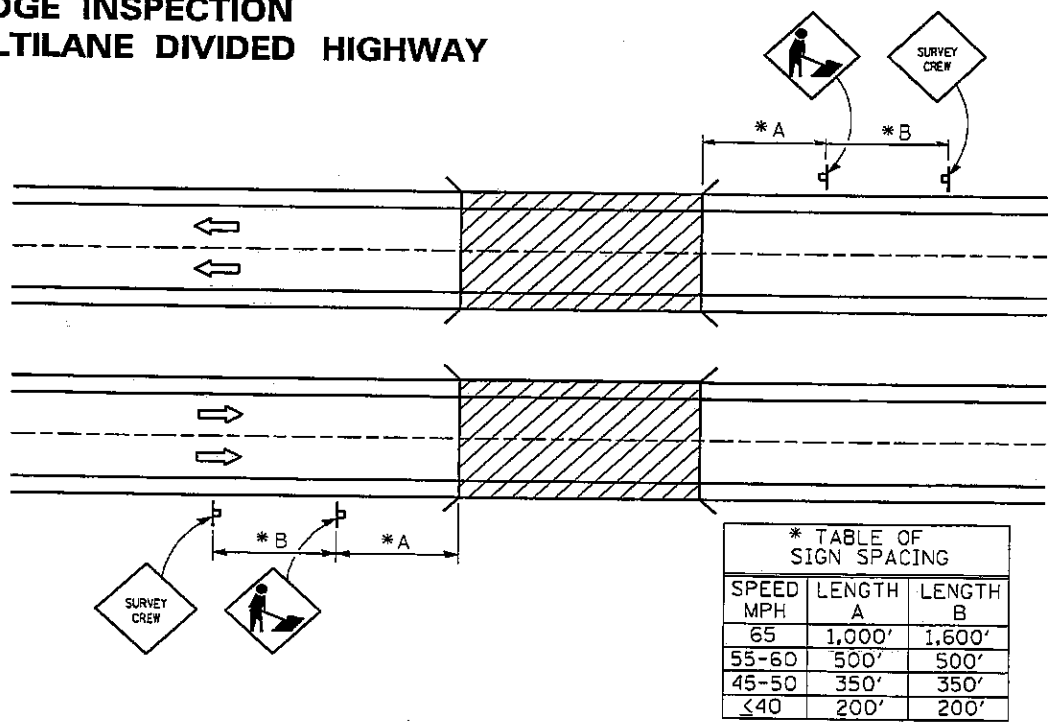

WZ B2

Notes:

May be performed without a flagger, provided:

1. Each task must be performed with extreme care.
2. The amount of time the workers are on the pavement shall be minimized.
3. Workers shall enter onto the pavement only during appropriate gaps in traffic.
4. Adequate sight distance must be available to utilize this case.
5. If workers must remain in traffic lane and appropriate gaps do not exist, the lane must be closed with proper traffic control signs and devices.
6. Vehicle may not encroach onto the pavement.
7. Vehicle shall have its strobe lights on.

No attempts shall be made to stop, slow, or direct traffic into another lane except by a properly equipped flagger with proper warning signs in place.

When it is necessary for the vehicle to stop on the roadway, traffic control shall be in accordance with the proper case.

This case is allowed during non-peak traffic.

Full lane closure should be considered when work at one location would exceed one hour.

BRIDGE INSPECTION MULTILANE UNDIVIDED HIGHWAY

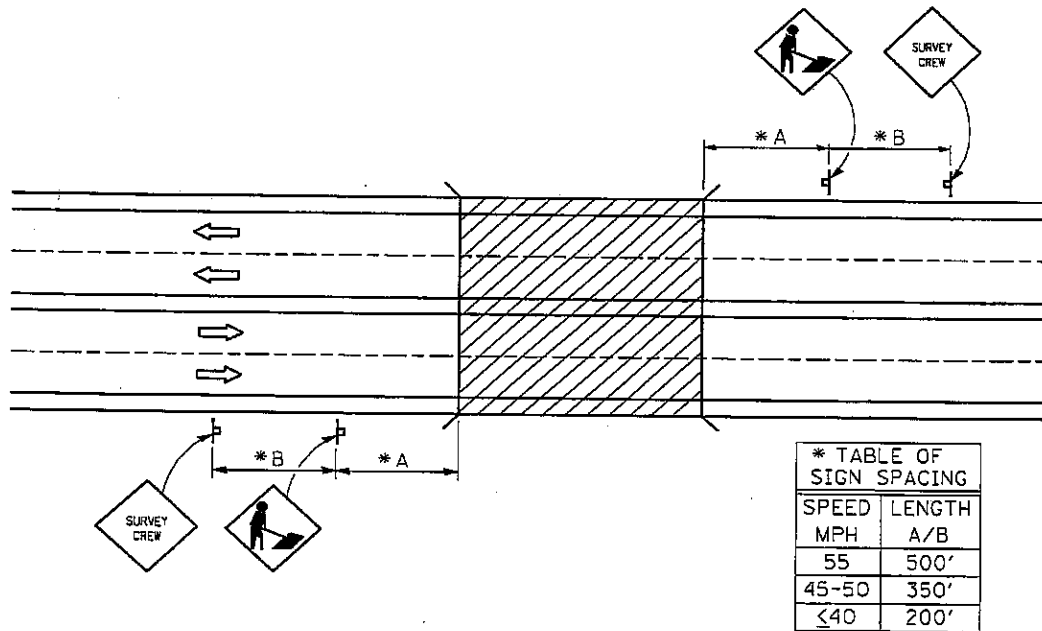

WZ B3

Notes:

May be performed without a flagger, provided:

1. Each task must be performed with extreme care.
2. The amount of time the workers are on the pavement shall be minimized.
3. Workers shall enter onto the pavement only during appropriate gaps in traffic.
4. Adequate sight distance must be available to utilize this case.
5. If workers must remain in traffic lane and appropriate gaps do not exist, the lane must be closed with proper traffic control signs and devices.
6. Vehicle may not encroach onto the pavement.
7. Vehicle shall have its strobe lights on.

No attempts shall be made to stop, slow, or direct traffic into another lane except by a properly equipped flagger with proper warning signs in place.

When it is necessary for the vehicle to stop on the roadway, traffic control shall be in accordance with the proper case.

This case is allowed during non-peak traffic.

Full lane closure should be considered when work at one location would exceed one hour.

Special Cases Cases WZ-S Survey

**SURVEY WORK
MOVING OPERATION ON PAVEMENT
2 LANE 2 WAY
INSTRUMENT NOT ON PAVEMENT
ADEQUATE SIGHT DISTANCE**

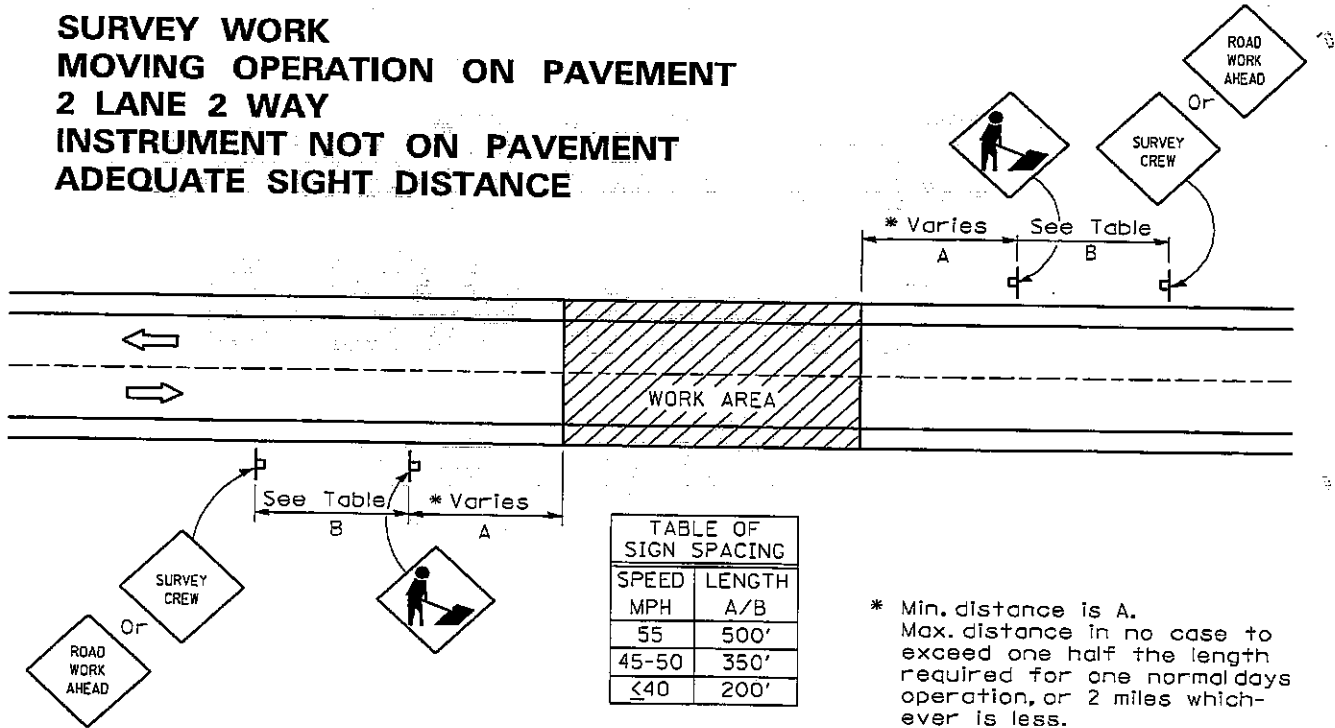

* Min. distance is A.
Max. distance in no case to exceed one half the length required for one normal days operation, or 2 miles which-ever is less.

Notes:

May be performed without a flagger, provided:

1. Each task must be performed with extreme care.
2. The amount of time the workers are on the pavement shall be minimized.
3. Workers shall enter onto the pavement only during appropriate gaps in traffic.
4. Adequate sight distance must be available to utilize this case.
5. If workers must remain in traffic lane and appropriate gaps do not exist, the lane must be closed with proper traffic control signs and devices.
6. Vehicle may not encroach onto the pavement.
7. Vehicle shall have its strobe lights on.

No attempts shall be made to stop, slow, or direct traffic into another lane except by a properly equipped flagger with proper warning signs in place.

When it is necessary for the vehicle to stop on the roadway, traffic control shall be in accordance with the proper case.

This case is allowed during non-peak traffic.

Full lane closure should be considered when work at one location would exceed one hour.

**SURVEY WORK
MOVING OPERATION ON PAVEMENT
2 LANE 2 WAY WITH / WITHOUT
INSTRUMENT ON PAVEMENT
INADEQUATE SIGHT DISTANCE**

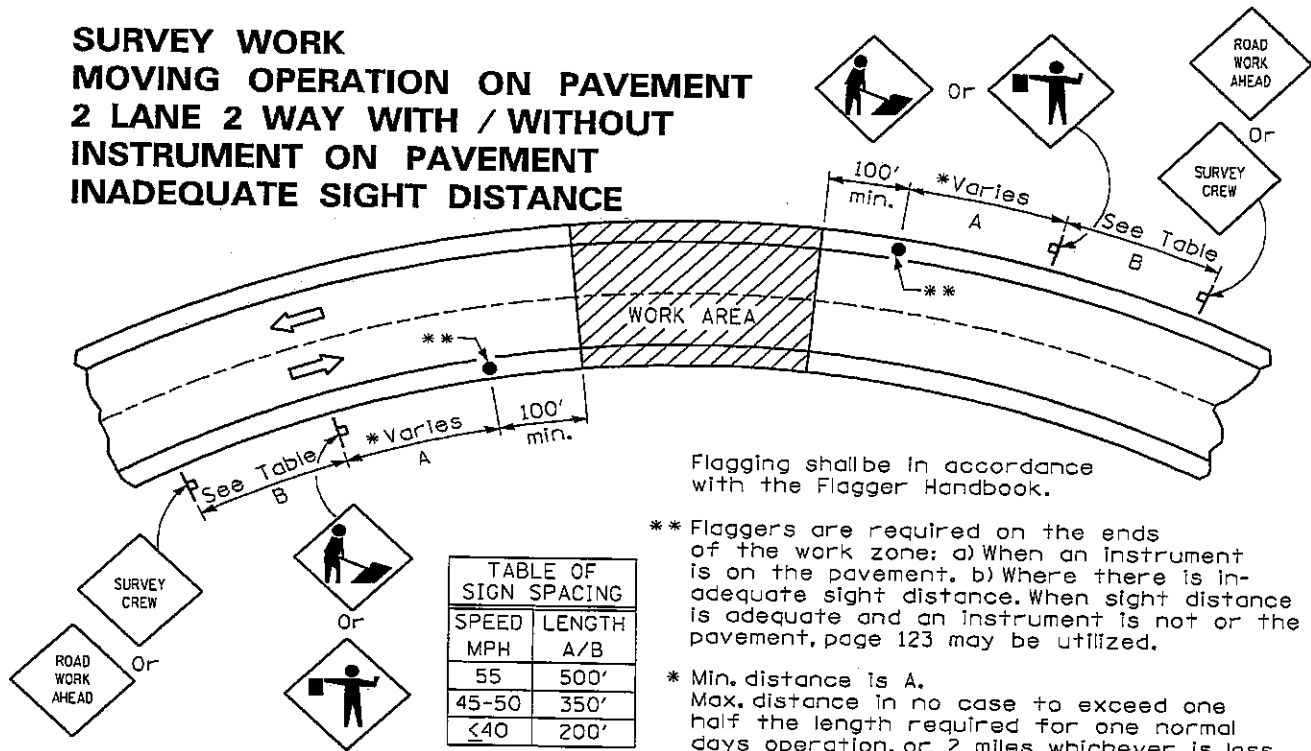

Flagging shall be in accordance with the Flagger Handbook.

** Flaggers are required on the ends of the work zone: a) When an instrument is on the pavement. b) Where there is inadequate sight distance. When sight distance is adequate and an instrument is not on the pavement, page 123 may be utilized.

* Min. distance is A. Max. distance in no case to exceed one half the length required for one normal days operation, or 2 miles whichever is less.

WZ S2

Notes:

May be performed without a flagger, provided:

1. Each task must be performed with extreme care.
2. The amount of time the workers are on the pavement shall be minimized.
3. Workers shall enter onto the pavement only during appropriate gaps in traffic.
4. Adequate sight distance must be available to utilize this case.
5. If workers must remain in traffic lane and appropriate gaps do not exist, the lane must be closed with proper traffic control signs and devices.
6. Vehicle may not encroach onto the pavement.
7. Vehicle shall have its strobe lights on.

No attempts shall be made to stop, slow, or direct traffic into another lane except by a properly equipped flagger with proper warning signs in place.

When it is necessary for the vehicle to stop on the roadway, traffic control shall be in accordance with the proper case.

This case is allowed during non-peak traffic.

Full lane closure should be considered when work at one location would exceed one hour.

**SURVEY WORK
MOVING WORK AREA, 2 LANE 2 WAY
INSTRUMENT IS NOT ON PAVEMENT
INADEQUATE SIGHT DISTANCE
INTERMITTENT ENCROACHMENT**

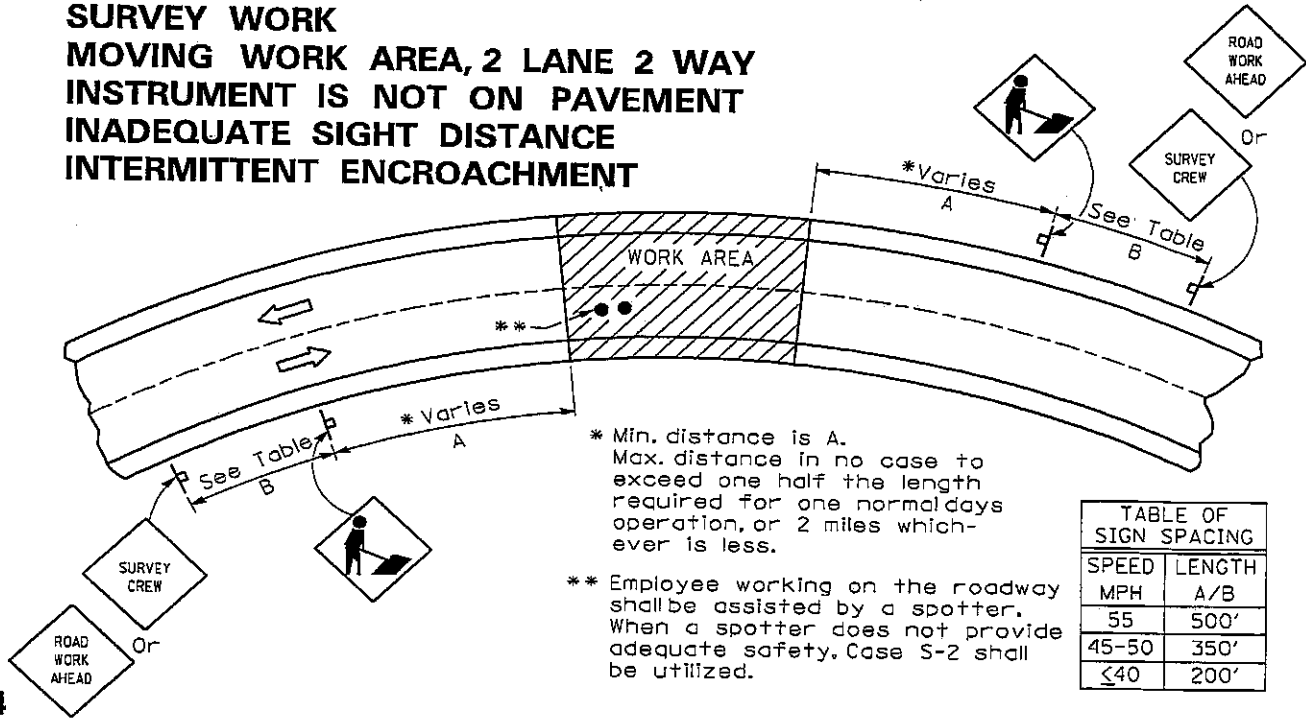

* Min. distance is A.
Max. distance in no case to exceed one half the length required for one normal days operation, or 2 miles which-ever is less.

** Employee working on the roadway shall be assisted by a spotter. When a spotter does not provide adequate safety. Case S-2 shall be utilized.

TABLE OF SIGN SPACING	
SPEED MPH	LENGTH A/B
55	500'
45-50	350'
<40	200'

WZ S3

Notes:

May be performed without a flagger, provided:

1. Each task must be performed with extreme care.
2. The amount of time the workers are on the pavement shall be minimized.
3. Workers shall enter onto the pavement only during appropriate gaps in traffic.
4. Adequate sight distance must be available to utilize this case.
5. If workers must remain in traffic lane and appropriate gaps do not exist, the lane must be closed with proper traffic control signs and devices.
6. Vehicle may not encroach onto the pavement.
7. Vehicle shall have its strobe lights on.

No attempts shall be made to stop, slow, or direct traffic into another lane except by a properly equipped flagger with proper warning signs in place.

When it is necessary for the vehicle to stop on the roadway, traffic control shall be in accordance with the proper case.

This case is allowed during non-peak traffic.

Full lane closure should be considered when work at one location would exceed one hour.

**SURVEY WORK
MOVING WORK AREA
MULTILANE ROADWAY
INSTRUMENT IS NOT ON PAVEMENT
ADEQUATE SIGHT DISTANCE**

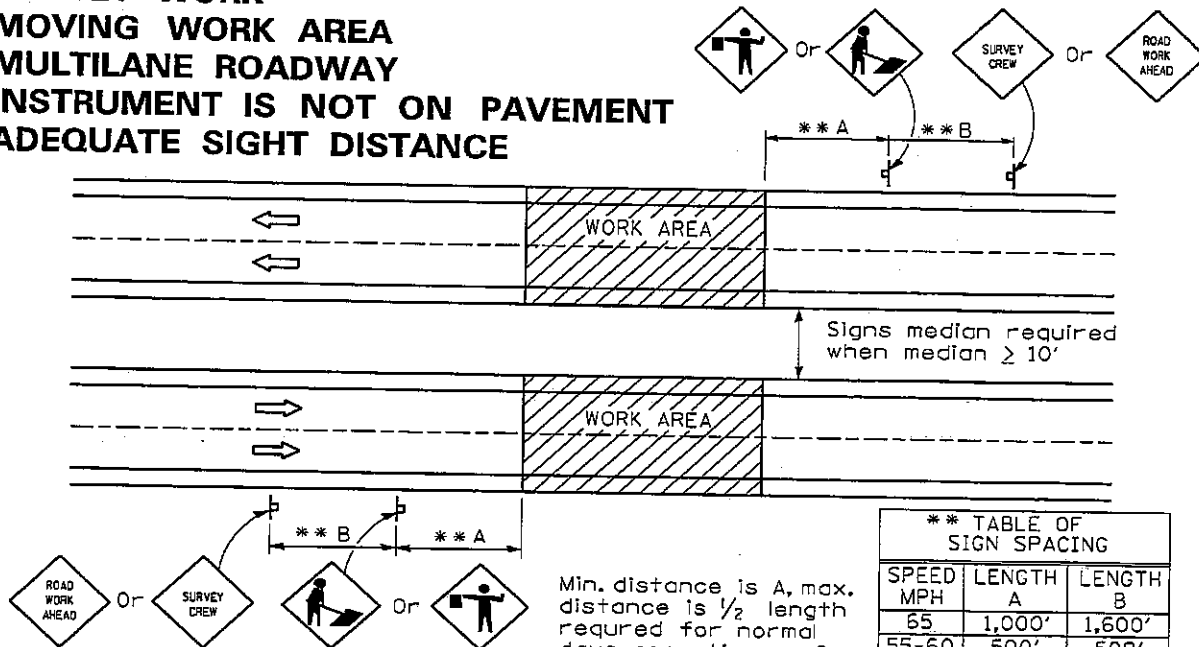

WZ S4

Notes:

May be performed without a flagger, provided:

1. Each task must be performed with extreme care.
2. The amount of time the workers are on the pavement shall be minimized.
3. Workers shall enter onto the pavement only during appropriate gaps in traffic.
4. Adequate sight distance must be available to utilize this case.
5. If workers must remain in traffic lane and appropriate gaps do not exist, the lane must be closed with proper traffic control signs and devices.
6. Vehicle may not encroach onto the pavement.
7. Vehicle shall have its strobe lights on.

No attempts shall be made to stop, slow, or direct traffic into another lane except by a properly equipped flagger with proper warning signs in place.

When it is necessary for the vehicle to stop on the roadway, traffic control shall be in accordance with the proper case.

This case is allowed during non-peak traffic.

Full lane closure should be considered when work at one location would exceed one hour.

**SURVEY WORK
STATIONARY WORK AREA
CENTERLINE WORK
LOW VOLUME ROADWAY
ADEQUATE SIGHT DISTANCE**

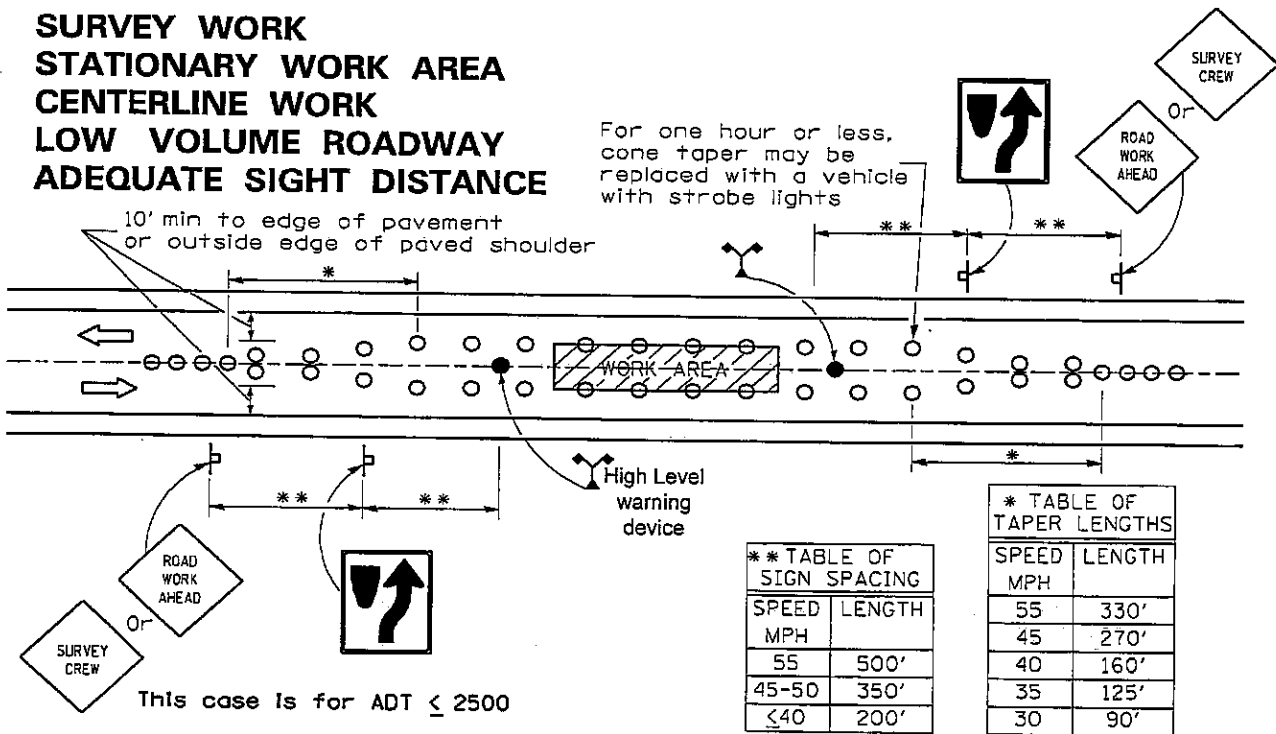

WZ S5

Notes:

Each task must be performed with extreme care

Workers shall cross the pavement only during appropriate gaps in traffic.

No attempts shall be made to stop, slow, or direct traffic into another lane except by properly equipped flagger with proper warning signs in place.

Special Cases

WZ-W

Weigh Scales

**STATE POLICE / IDOT TRUCK WEIGH SCALES OR
OFFICE OF QUALITY COMPLIANCE AND REVIEW CREW
MULTILANE ROADWAY AT INTERCHANGE**

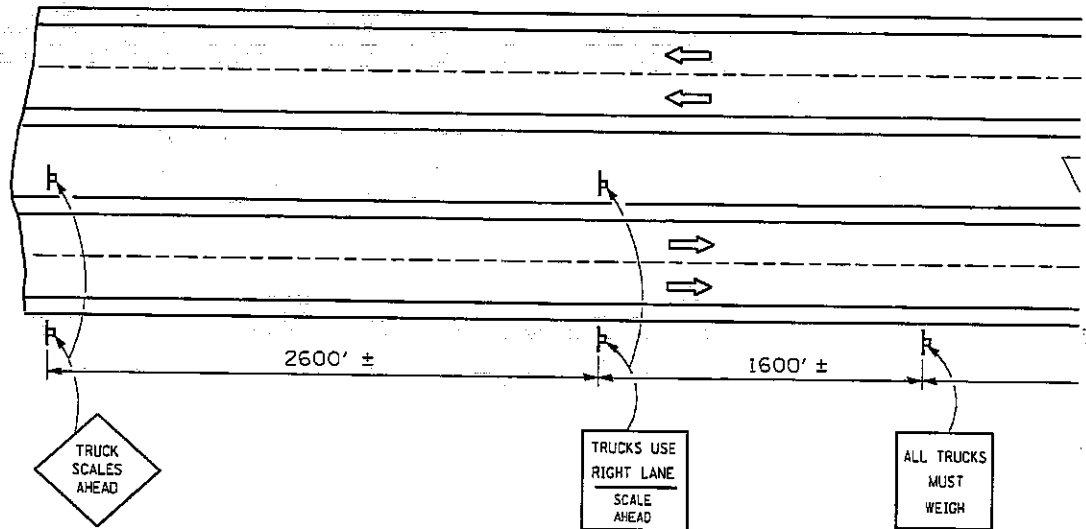

WZ W1

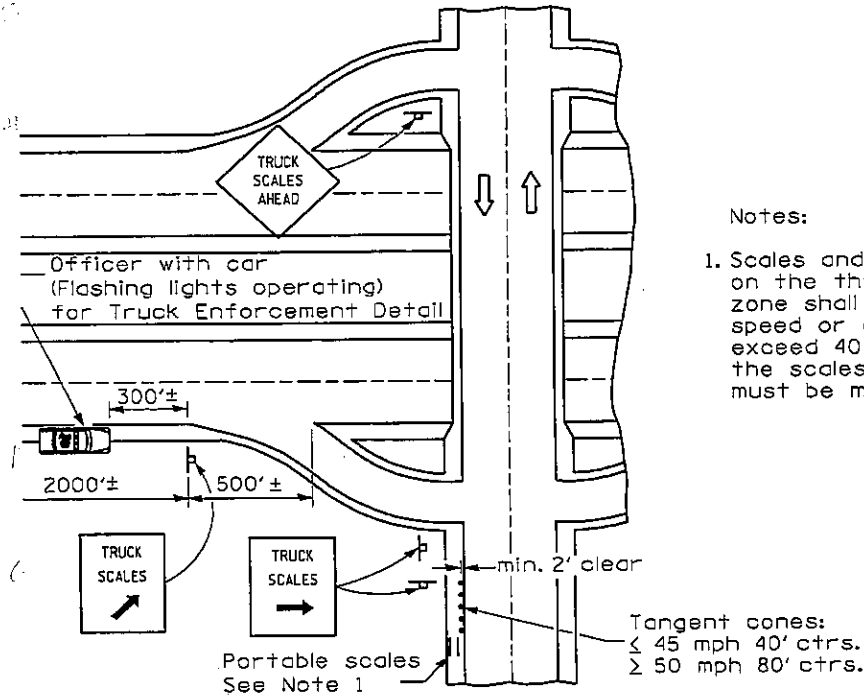

Notes:

1. Scales and cones shall not encroach on the through lane and a 2 foot clear zone shall be maintained. If the posted speed or operating speeds at the location exceed 40 mph, a 4 foot clear zone between the scales and the edge of pavement must be maintained.

STATE-POLICE / IDOT TRUCK WEIGH SCALES-ONLY MULTILANE ROADWAY ON / ALONG ROADWAY

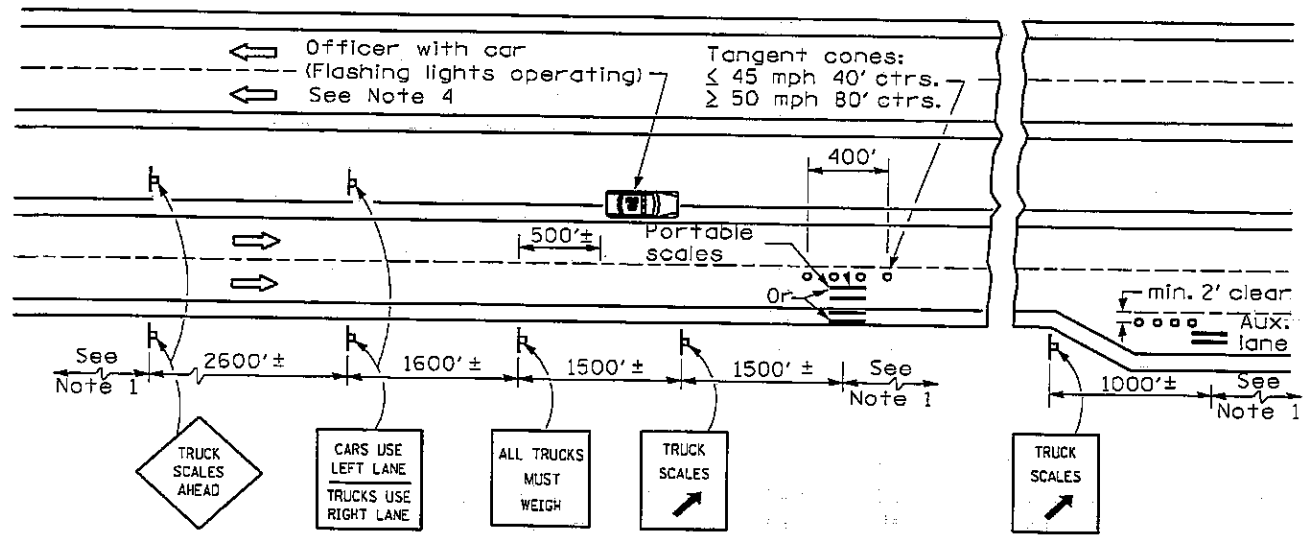

Notes:

1. For full access control; signing should be at least 5,000 feet beyond preceeding interchange entrance ramp and scales should be at least 2,000 feet in advance of the exit gore for the next interchange. On other highways, scales should be located away from major intersections, when practical.
2. Signing at intersections should be in conformance with Traffic Control Plan V or VI.
3. Weighing on Interstate Routes is allowed only at approved locations (see instruction sheet for location selection).
4. Police car may be located off the edge of the right shoulder when there is insufficient space to park on left.
5. On highways with < 10' median eliminate signs on left. Lane closure not allowed on non-divided highways having posted speed greater than 45 mph.

STATE POLICE / IDOT TRUCK WEIGH SCALES OR OFFICE OF QUALITY COMPLIANCE AND REVIEW CREW MULTILANE ROADWAY NON INTERSTATE

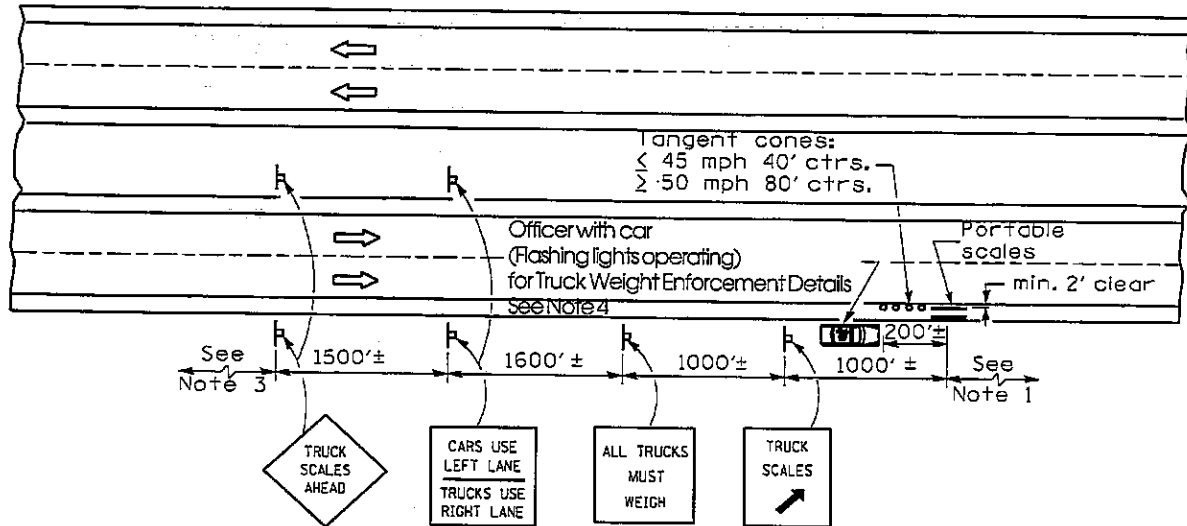

Notes:

1. For full access control; signing should be at least 5,000 feet beyond preceeding interchange entrance ramp and scales should be at least 2,000 feet in advance of the exit gore for the next interchange. On other highways, scales should be located away from major intersections, when practical.
2. Signing at intersections should be in conformance with Traffic Control Plan V or VI.
3. On highways, with less than 10 foot wide median, eliminate signs on left. Lane closure not allowed on non-divided highways having posted speed greater than 45 mph.
4. Department trained flagger may also direct traffic, with IDOT vehicle with strobe lights.

STATE POLICE / IDOT TRUCK WEIGH SCALES OR OFFICE OF QUALITY COMPLIANCE AND REVIEW CREW 2 LANE 2 WAY ROADWAY

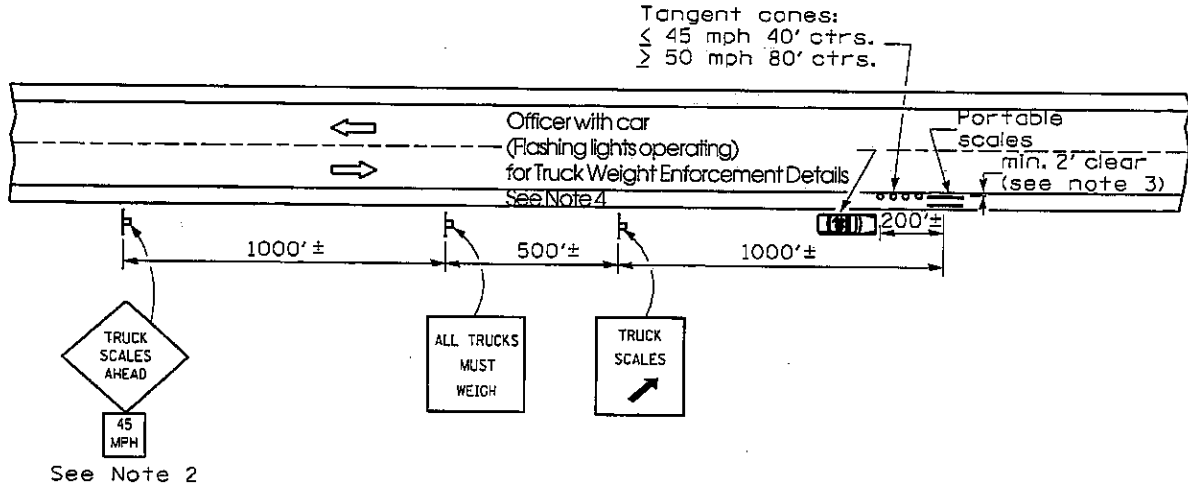

WZ W4

Notes:

1. Department trained flagger may also direct traffic with IDOT vehicle with strobe lights.
2. Use advisory speed plate on highways having a posted speed in excess of 45 mph.
3. Scales and cones shall not encroach on the through lane. If the posted speed or operating speeds at the location exceed 40 mph, a 4 foot clear zone between the scales and the edge of pavement must be maintained.

WZ W5

Notes:

1. Department trained flagger may also direct traffic with IDOT vehicle with strobe lights.
2. Use advisory speed plate on highways having a posted speed in excess of 45 mph.
3. Scales and cones shall not encroach on the through lane. If the posted speed or operating speeds at the location exceed 40 mph, a 4 foot clear zone between the scales and the edge of pavement must be maintained.
4. See Traffic control Plan II or III for additional signs needed when weighing on multilane highway.

STATE-POLICE /IDOT WEIGH SCALES-ONLY 2 LANE 2 WAY ROADWAY AT INTERSECTION 4 WAY INTERSECTION

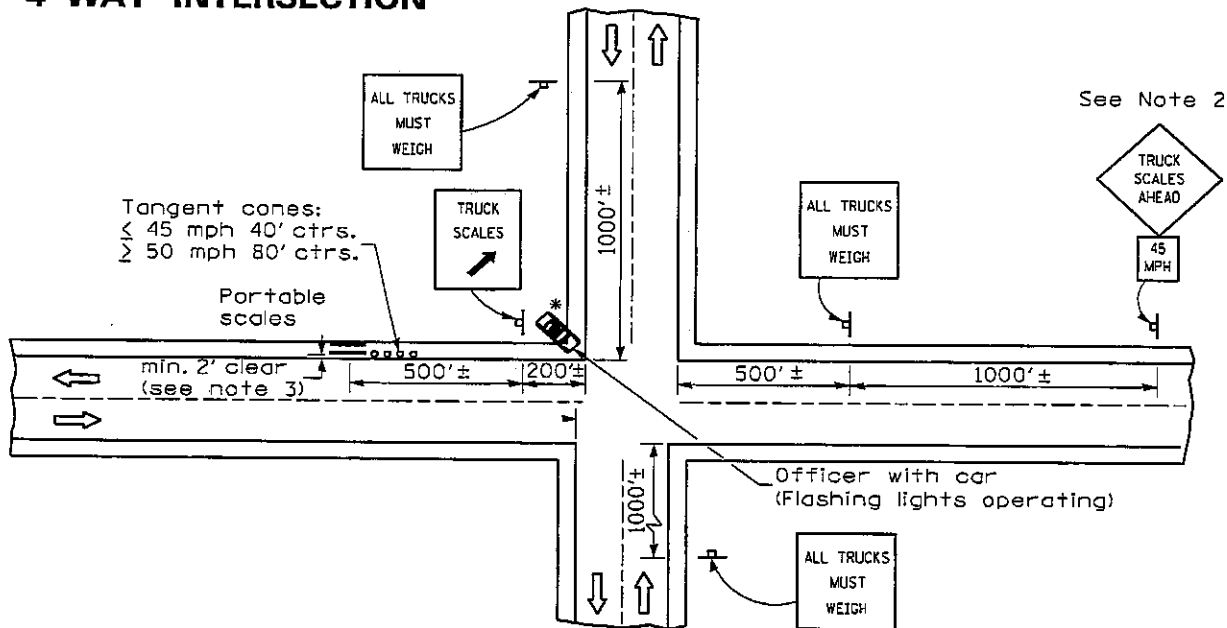

Notes:

- * 1. Department trained flagger may also direct traffic with IDOT vehicle with strobe lights.
2. Use advisory speed plate on highways having a posted speed in excess of 45 mph.
3. Scales and cones shall not encroach on the through lane. If the posted speed or operating speeds at the location exceed 40 mph, a 4 foot clear zone between the scales and the edge of pavement must be maintained.
4. See Traffic control Plan II or III for additional signs needed when weighing on multilane highway.

4

7

2

